

S
1 1/2'

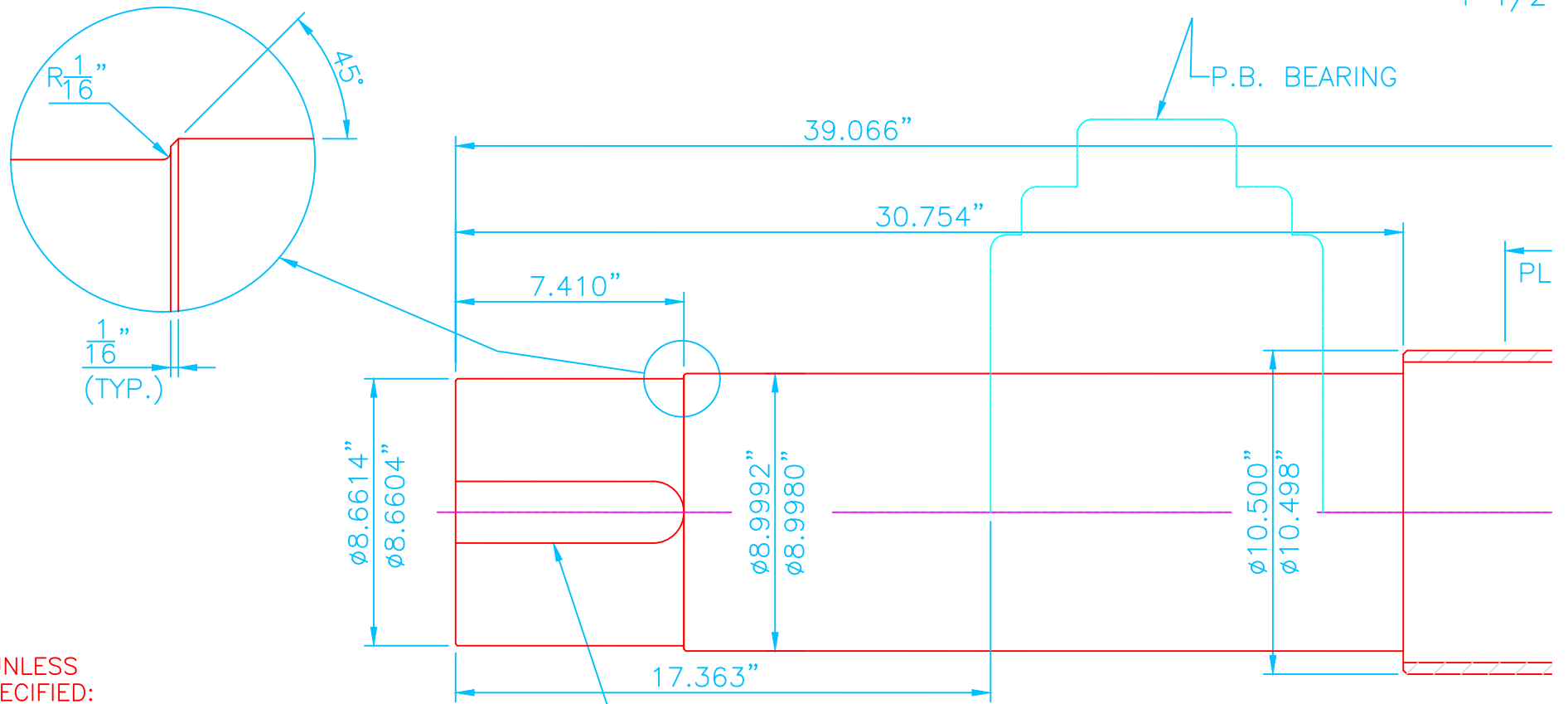

FINISHES UNLESS OTHERWISE SPECIFIED:
TOLERANCE FOR FABRICATION $\pm 1/32$ "
TOLERANCE FOR MACHINING:
- .004"
+ .004"
 $\pm .004$ "

DETAIL "2"

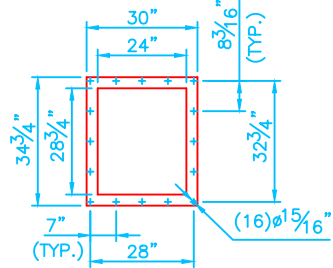
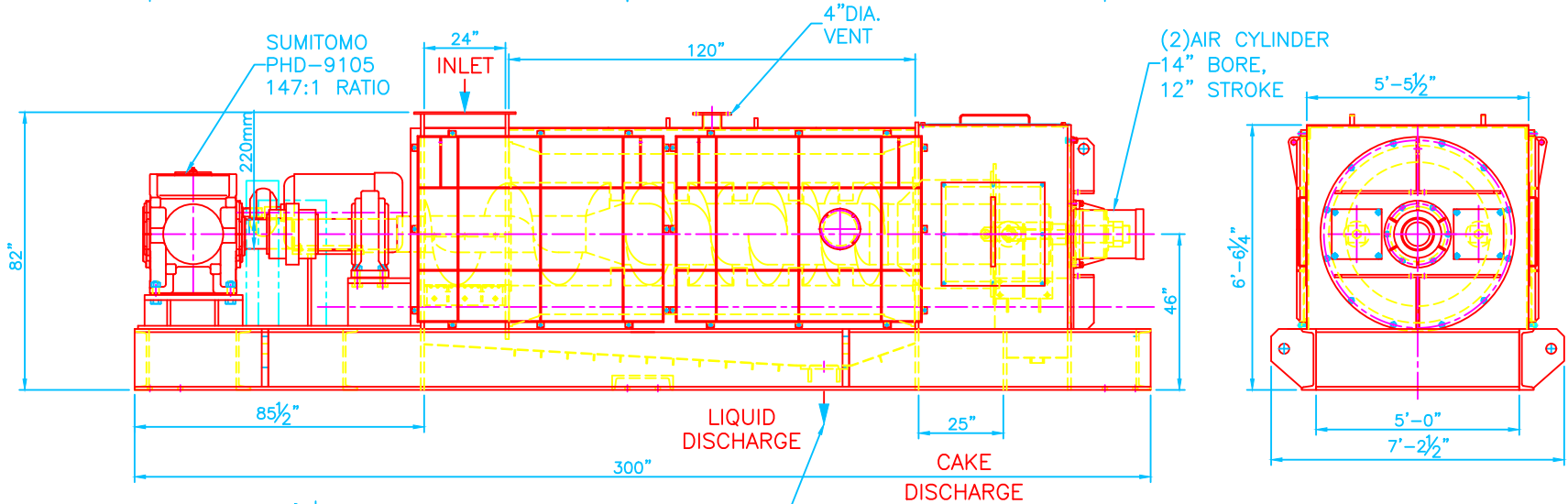
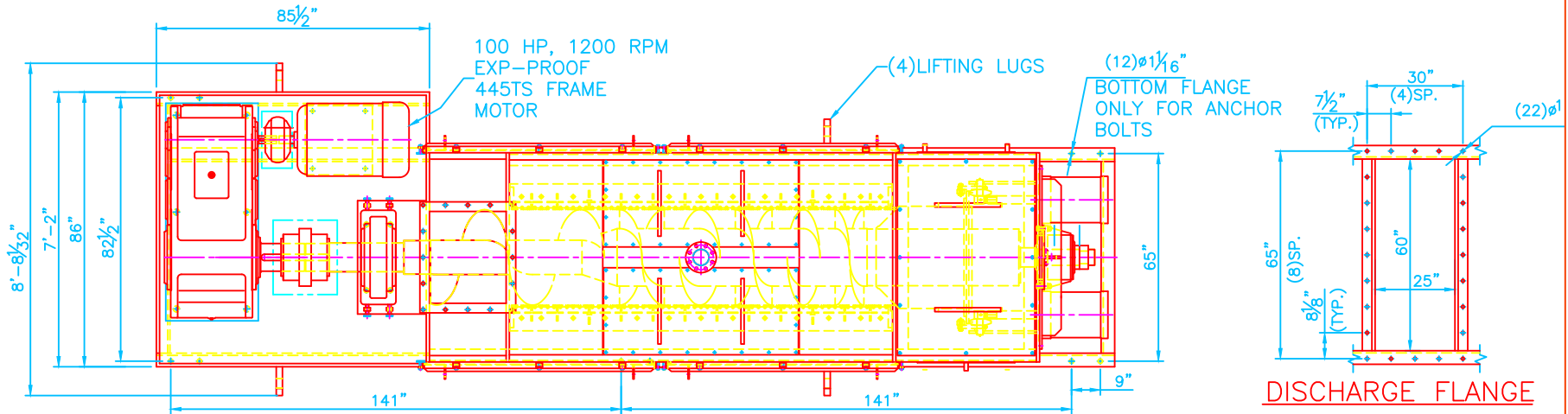

(4) 3/4"-10 UNC x 2 1/2" LG. STUD BOLT AT 90° ON A 9 1/2" DIA. B.C. 6 3/4" DIA. HOLE MAIN DRAIN

INLET FLANGE

TOLERANCES UNLESS OTHERWISE SPECIFIED		Vincent CORPORATION TAMPA, FLORIDA	
FRACT. DECIM. ANGUL. ± 1/32 ± .004 ± .5°		VP-30 PRESS	
APPROVALS DATE		GENERAL DIMENSIONS	
DRAWN EG 05/25/07		ADM (T-6041)	
CHECKED		THIS PRINT IS THE PROPERTY OF VINCENT CORPORATION AND IS RECALLABLE AT ANY TIME. IT MUST NOT BE COPIED OR USED DETRIMENTALLY TO OUR INTERESTS.	
COMP. NAME 07037 Master		SIZE 140% PART NO. A 94276	
W. O. NO. 07037		SCALE N T S - DO NOT SCALE DWG. SHEET	

PA
BE
SO
MA
HO
TO
CO
TH
SE
VA
VA
CO
SE
MC

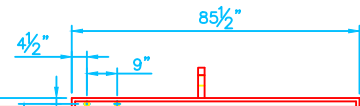
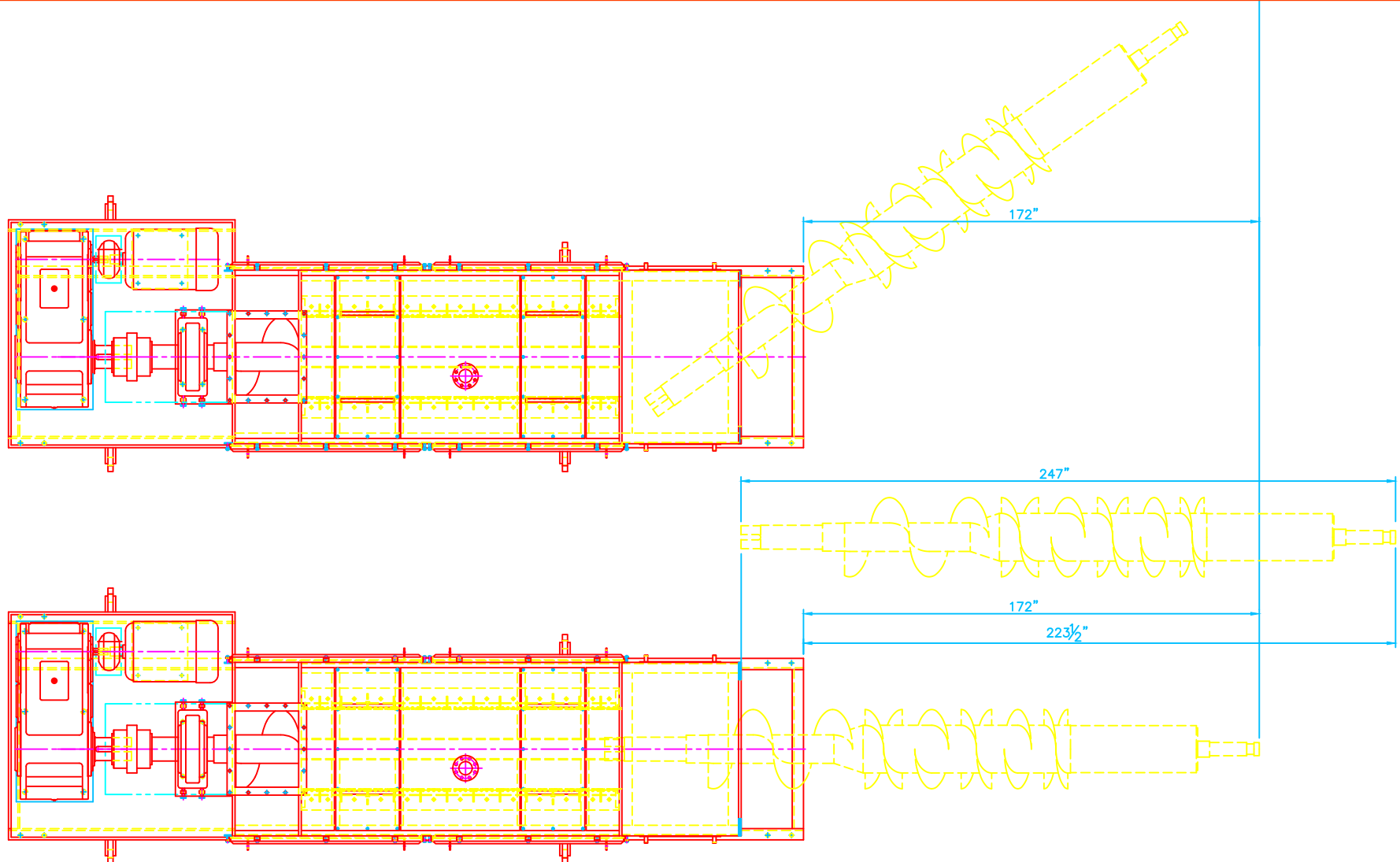

150 HP, 1800 RPM
445T FRAME
MOTOR

(4) LIFTING LUGS

TOLERANCES UNLESS OTHERWISE SPECIFIED		Vincent CORPORATION TAMPA, FLORIDA	
FRACT.	DECIM.		
± 1/32	± .004	± .5°	VP-30 PRESS SCREW REMOVAL DIAGRAM
APPROVALS	DATE		SIZE A
DRAWN	EG	05/25/07	
CHECKED			THIS PRINT IS THE PROPERTY OF VINCENT CORPORATION AND IS RECALLABLE AT ANY TIME. IT MUST NOT BE COPIED OR USED DETRIMENTALLY TO OUR INTERESTS.
COMP. NAME	07037_Master+		
W. O. NO.	07037		INCHES DO NOT SCALE DWG.
			SHEET

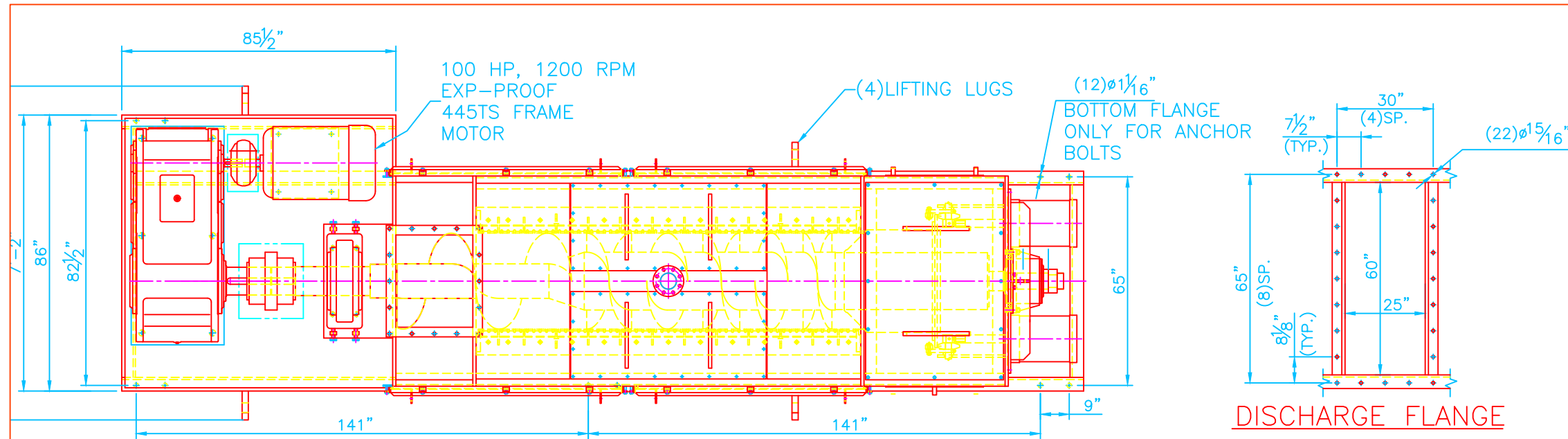

DISCHARGE FLANGE

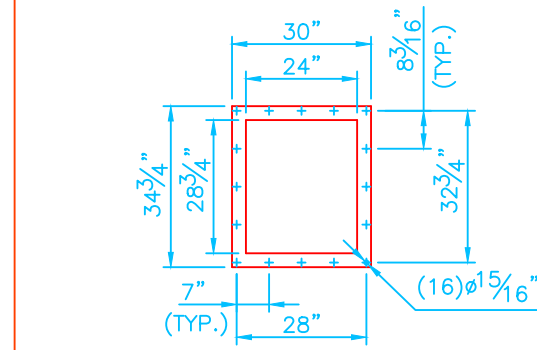
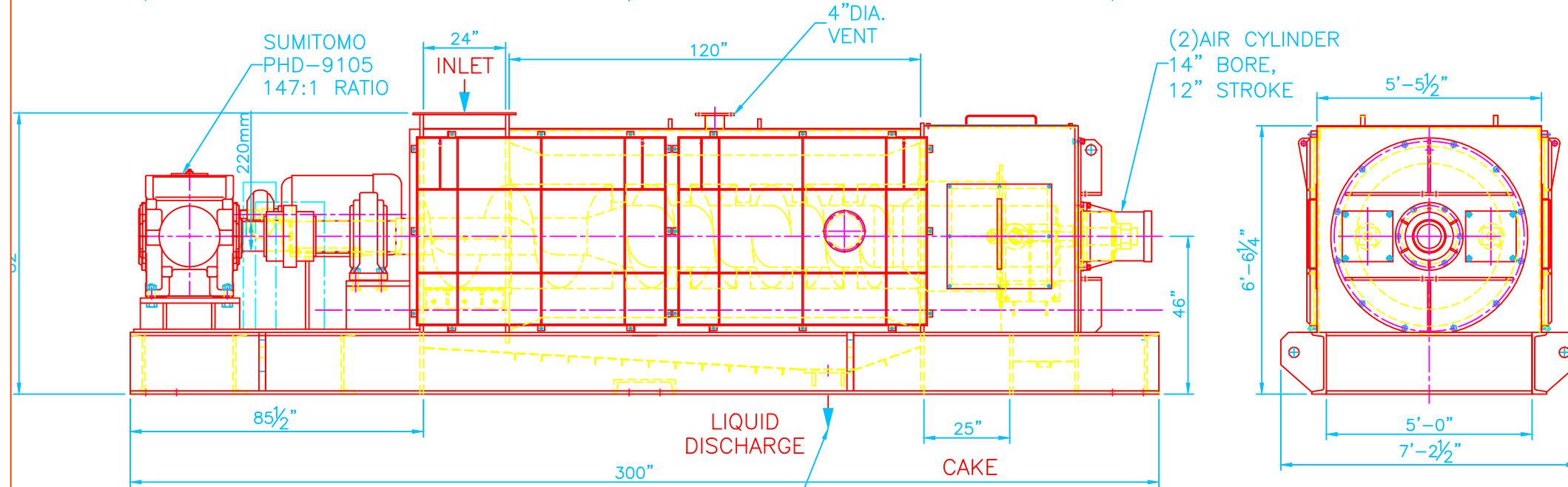

INLET FLANGE

(4) 3/4"-10 UNC x 2 1/2" LG. STUD BOLT AT 90° ON A 9 1/2" DIA. B.C. 6 3/4" DIA. HOLE MAIN DRAIN

DRIVE COMPONENTS:

- REDUCER - SUMITOMO, PHD 9105 P4, 147 : 1 RATIO
- MOTOR - SIEMENS 100 HP, 1200 RPM, 445TS FRAME
- DRIVE END BEARING - COOPER, 02BCP900 EXAT
- MOTOR/REDUCER COUPLING - DODGE, PX 140TL PARA-FLAX
- REDUCER/SHAFT COUPLING - FALK, 1060G20, 220mm HUBS
- DISCHARGE END BEARING - VINCENT WITH (2)#29430 THRUST BRNG
- DRIVE END SEALS - (2) JMC #1050-15055 RPD
- DISCHARGE END SEALS - JMC #7179 RPD, #0750-8432 RUP
- DISCHARGE END - RAYEESFORD SPLIT COLLAR 3-15/16" DIA.
- AIR CYLINDER - (2)PARKER, 14.00JB2AUS14A12.00

PARTS LIST:

- BED FRAME ASSEMBLY, SEE C-94278
- SCREW SHAFT ASSEMBLY, SEE C-94282
- MAIN SCREEN FRAME ASSEMBLY, SEE C-94284
- HOPPER SCREEN FRAME ASSEMBLY, SEE C-94285
- TOP AND BOTTOM RESISTOR BARS, SEE C-94286
- CONE ASSEMBLY, SEE C-94287
- CONE DRIVE MECHANISM, SEE C-94289
- THRUST BEARING ASSEMBLY, SEE C-94291
- THRUST FLANGE ASSEMBLY, SEE C-94292
- SEAL PLATE ASSEMBLY, SEE C-94293
- VAPOR TIGHT R/SIDE COVER, SEE C-94294
- VAPOR TIGHT L/SIDE COVER, SEE C-94294-A
- COLLAR CLUTCH ASSEMBLY, SEE B-94295
- SET OF COVERS FOR ONE UNIT, SEE C-94296
- MOTOR & REDUCER COUPLING COVERS, SEE C-94297

TOLERANCES UNLESS OTHERWISE SPECIFIED		Vincent CORPORATION TAMPA, FLORIDA	
FRACT.	DECIM. ANGUL.		
± 1/32	± .004 ± .5°	VP-30 PRESS GENERAL ASSEMBLY & PARTS LIST S/N 07037	
APPROVALS	DATE		
DRAWN EG	05/25/07	THIS PRINT IS THE PROPERTY OF VINCENT CORPORATION AND IS RECALLABLE AT ANY TIME. IT MUST NOT BE COPIED OR USED DETRIMENTALLY TO OUR INTERESTS.	
CHECKED		SIZE A	DRAWING NO. 94277
COMP. NAME 07037_Master+		SCALE N.T.S.	DO NOT SCALE DWG. SHEET
W. O. NO. 07037			

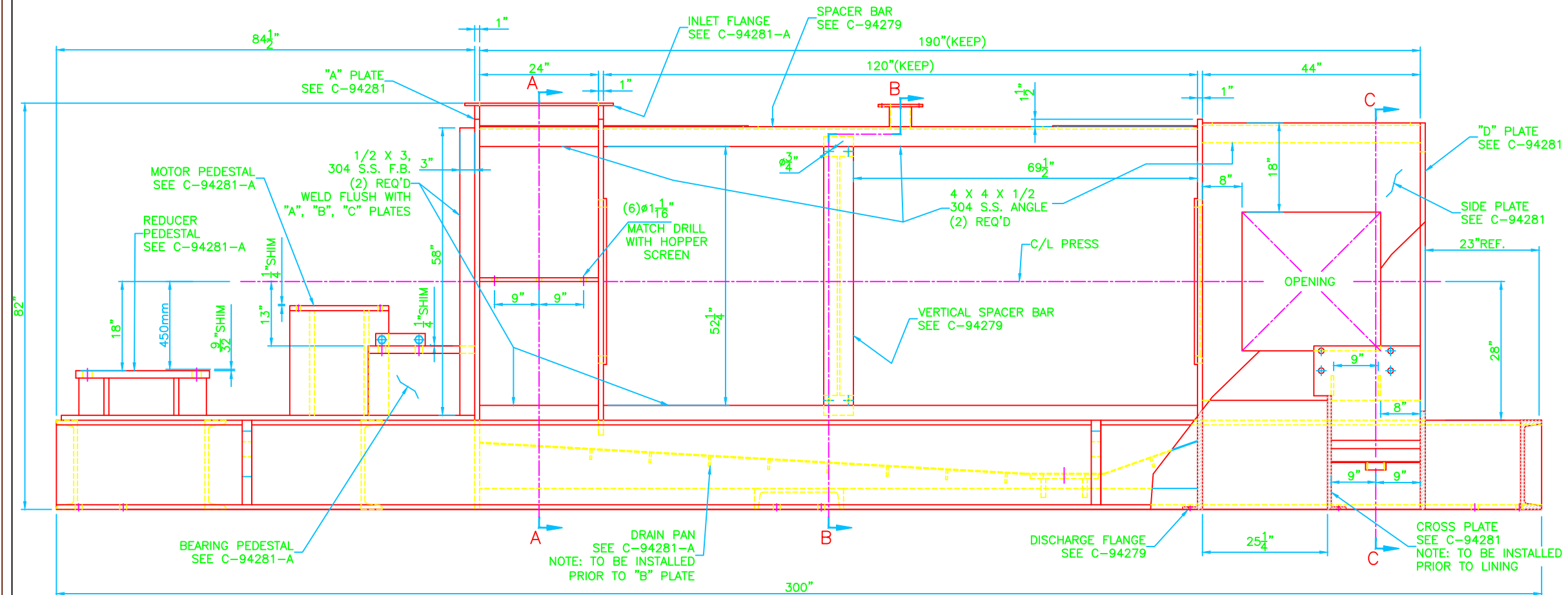

FRONT VIEW
(SEE TOP VIEW ON C-94279)

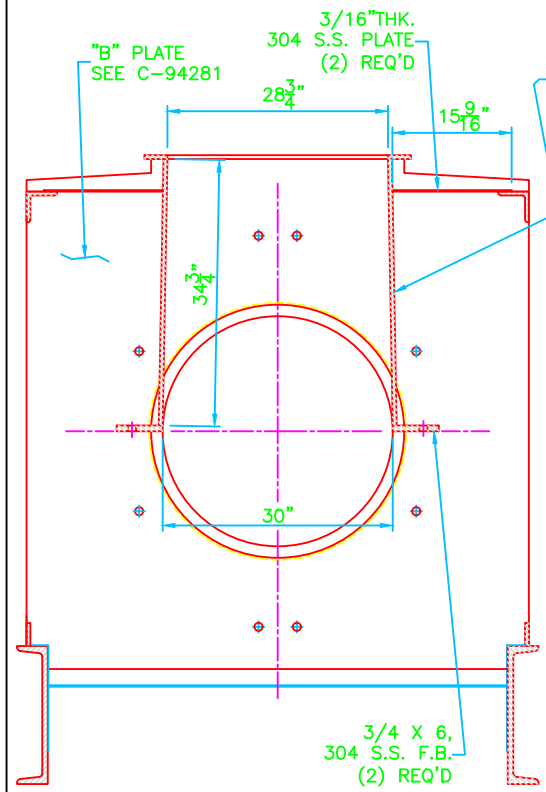

SECTION A-A

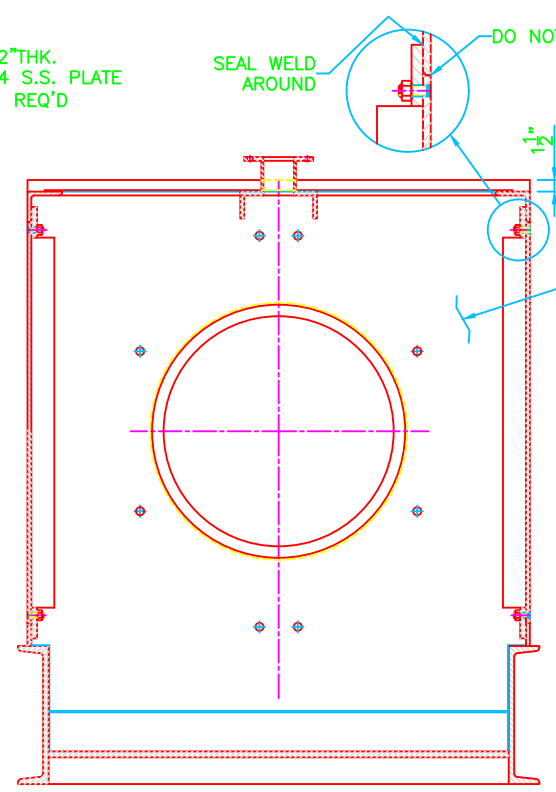

SECTION B-B

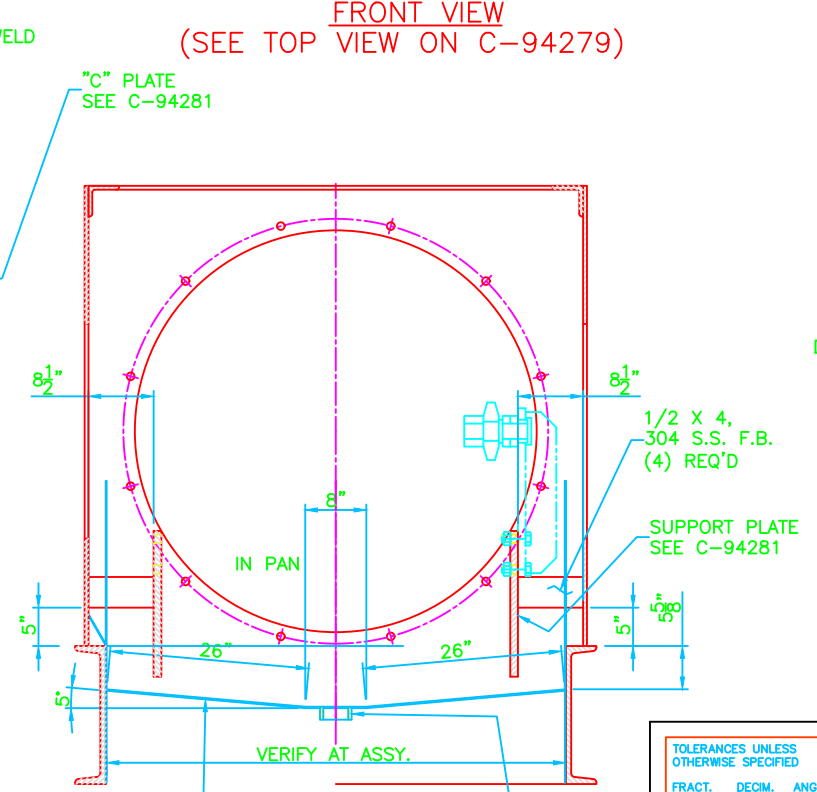

SECTION C-C

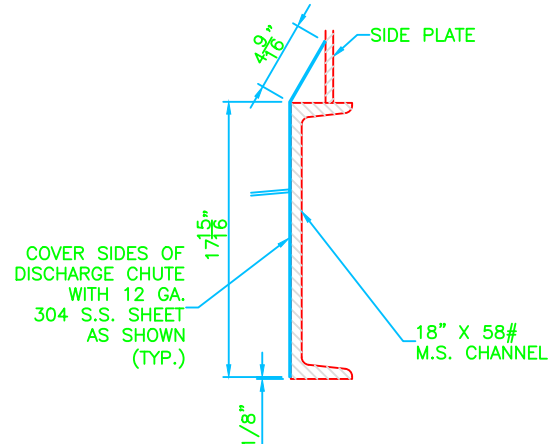

CAKE DISCHARGE LINING DETAILS
N.T.S.
MAT'L: 12 GA. 304 S.S. SHEET (BOTH SIDES)

TOLERANCES UNLESS OTHERWISE SPECIFIED		Vincent CORPORATION TAMPA, FLORIDA	
FRACT.	DECIM.	ANGUL.	VP-30 PRESS BED FRAME ASSEMBLY
± 1/32	± .004	± .5°	SCALE 16
APPROVALS	DATE	SIZE	DRAWING NO.
DRAWN EG	03/23/07	C	94278
CHECKED		THIS PRINT IS THE PROPERTY OF VINCENT CORPORATION AND IS RECALLABLE AT ANY TIME. IT MUST NOT BE COPIED OR USED DETRIMENTALLY TO OUR INTERESTS.	
COMP. NAME 07037_Master			
SCALE 3/4" = 1'-0"	DO NOT SCALE DWG.	SHEET 1 OF 2	

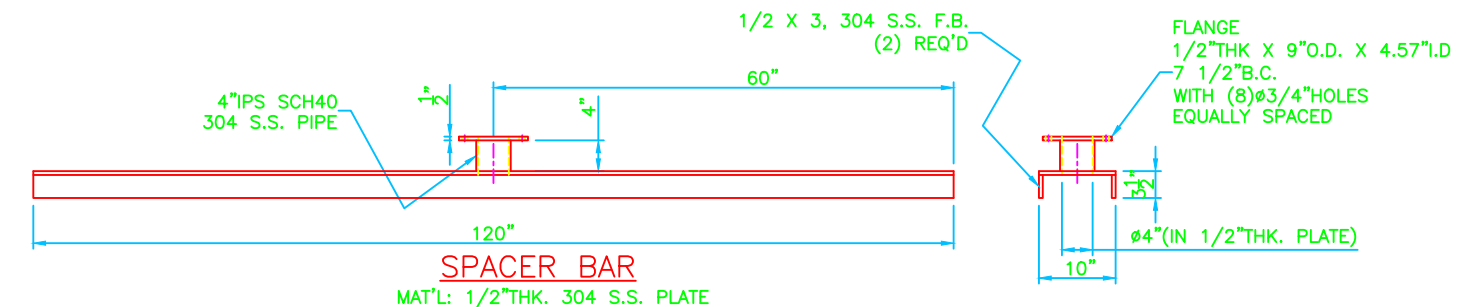
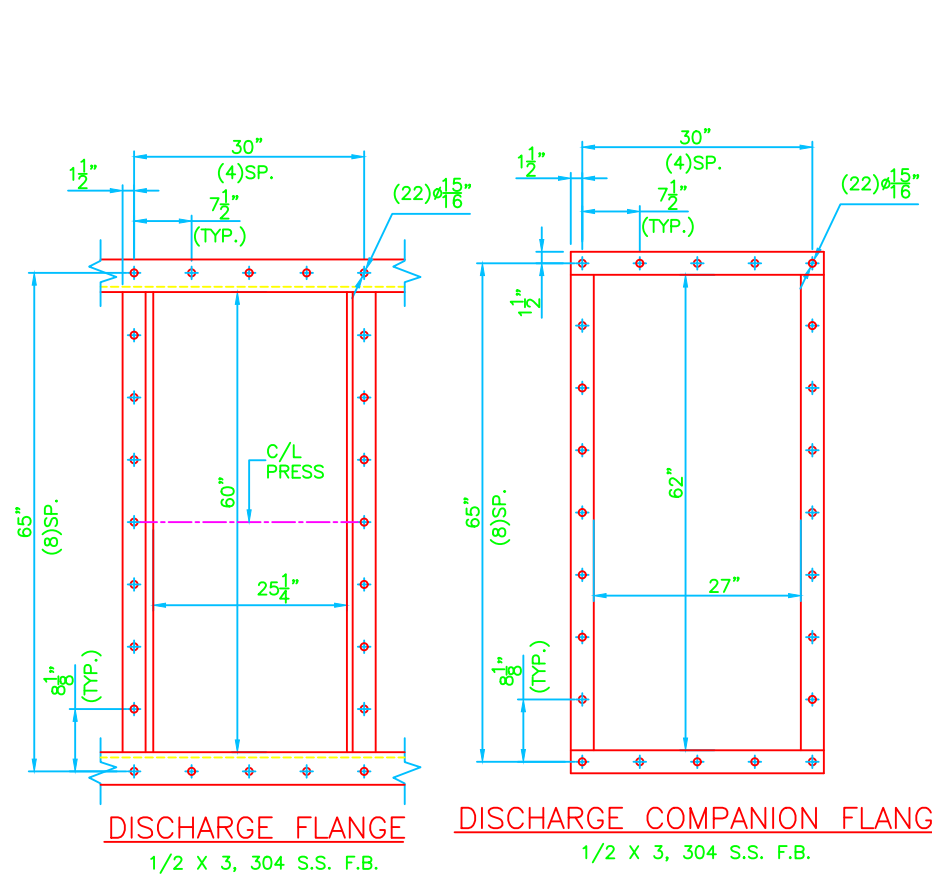
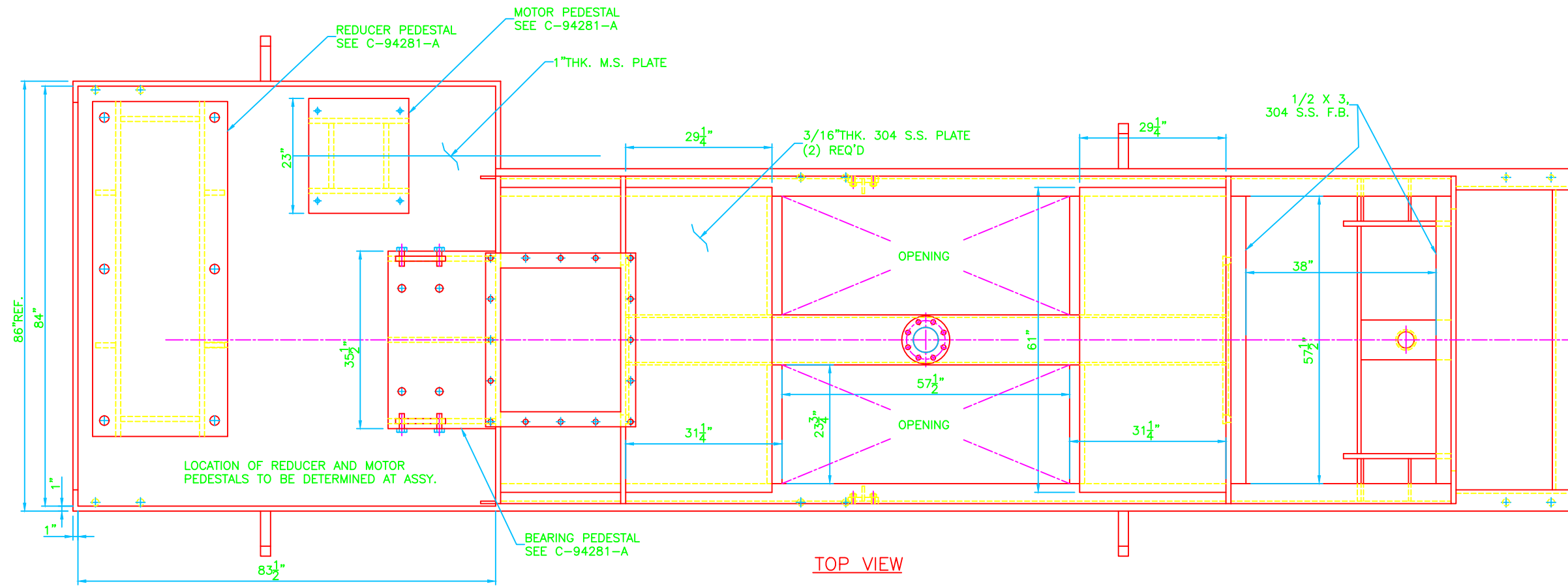

TOLERANCES UNLESS OTHERWISE SPECIFIED		Vincent CORPORATION TAMPA, FLORIDA	
FRACT.	DECIM.	ANGUL.	VP-30 PRESS BED FRAME ASSEMBLY
± 1/32	± .004	± 5°	SIZE C
APPROVALS	DATE	DRAWING NO. 94279	
DRAWN EG	03/23/07	THIS PRINT IS THE PROPERTY OF VINCENT CORPORATION AND IS RECALLABLE AT ANY TIME. IT MUST NOT BE COPIED OR USED DETRIMENTALLY TO OUR INTERESTS.	
CHECKED		W. O. NO. 07037	
COMP. NAME 07037_Master		SCALE 3/4" = 1'-0"	DO NOT SCALE DWG. SHEET 2 OF 2

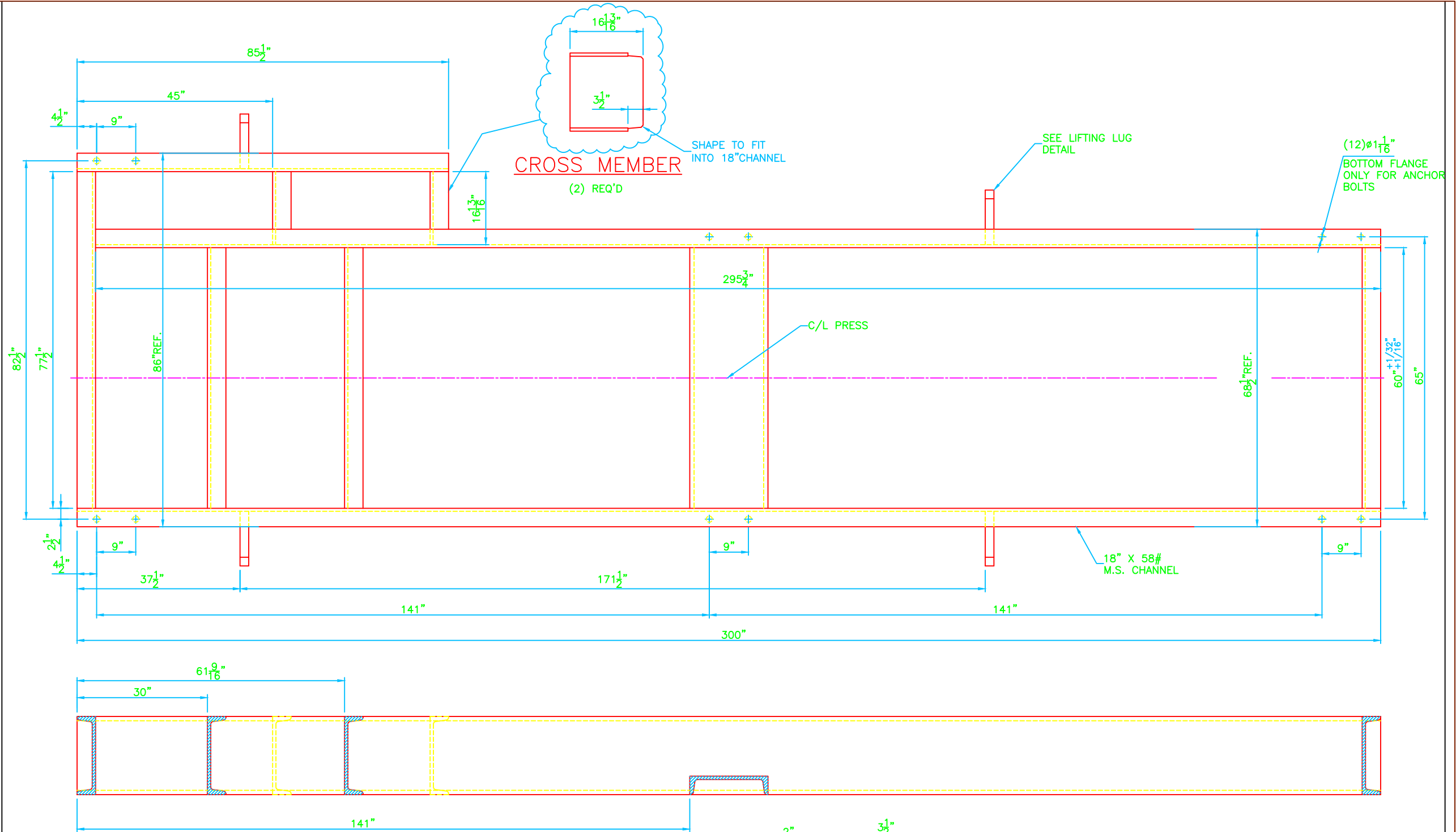

CROSS MEMBER
(2) REQ'D

SHAPE TO FIT INTO 18" CHANNEL

SEE LIFTING LUG DETAIL

(12) 1 1/8" BOTTOM FLANGE ONLY FOR ANCHOR BOLTS

C/L PRESS

18" X 58# M.S. CHANNEL

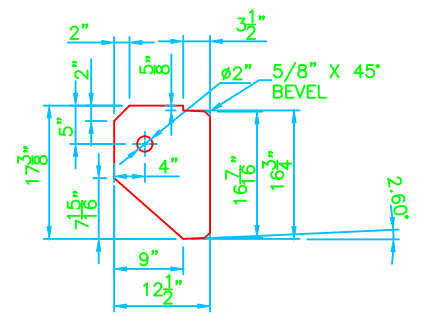

LIFTING LUG
MAT'L: 2" THK. M.S. PLATE
(4) REQ'D

TOLERANCES UNLESS OTHERWISE SPECIFIED		Vincent CORPORATION TAMPA, FLORIDA	
FRACT.	DECIM.	VP-30 PRESS BASE DETAILS	
± 1/32	± .004		
ANGUL.	± .5°		
APPROVALS	DATE		
DRAWN EG	05/29/07		
CHECKED			
COMP. NAME 07037_Master		SIZE C	DRAWING NO. 94280
W. O. NO. 07037		SCALE 3/4" = 1'-0"	DO NOT SCALE DWG. SHEET

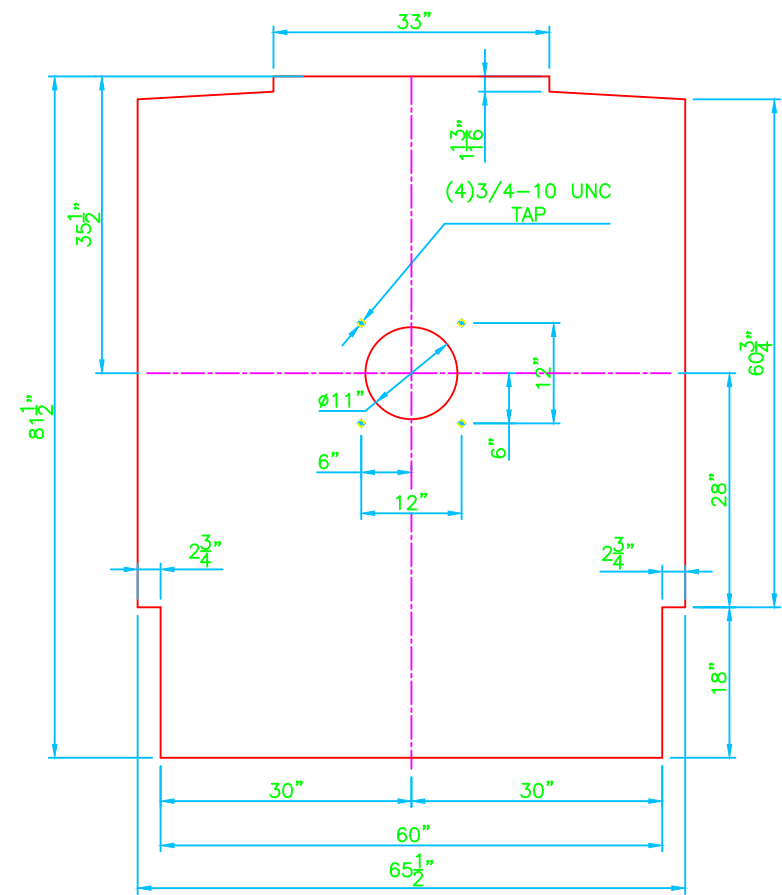

"A" PLATE
1"THK. 304 S.S. PLATE
(6) REQ'D

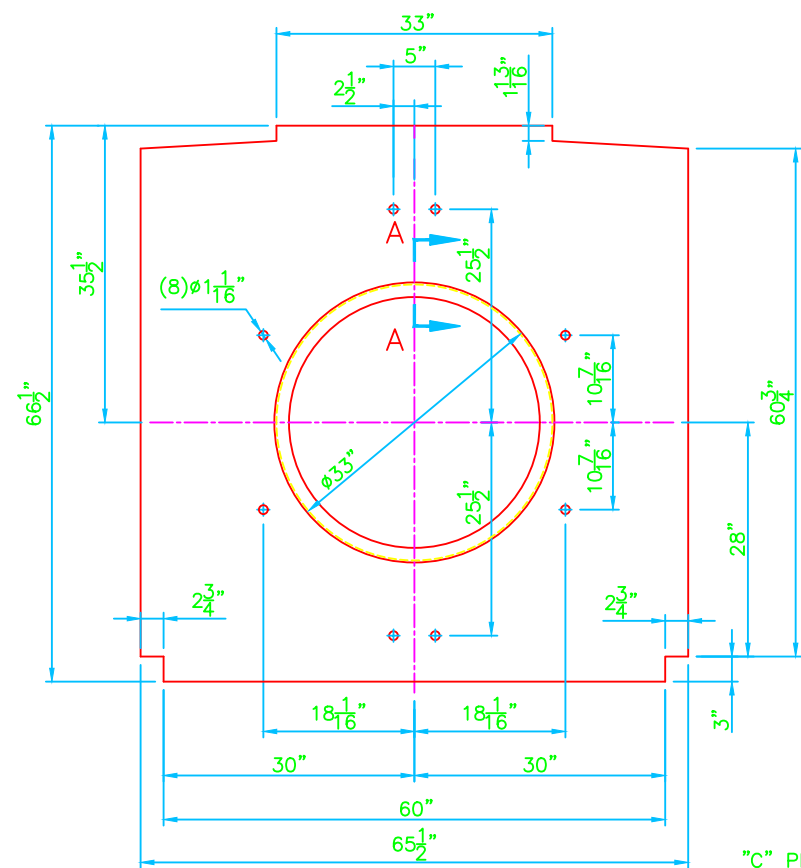

"B" PLATE
1"THK. 304 S.S. PLATE
(6) REQ'D

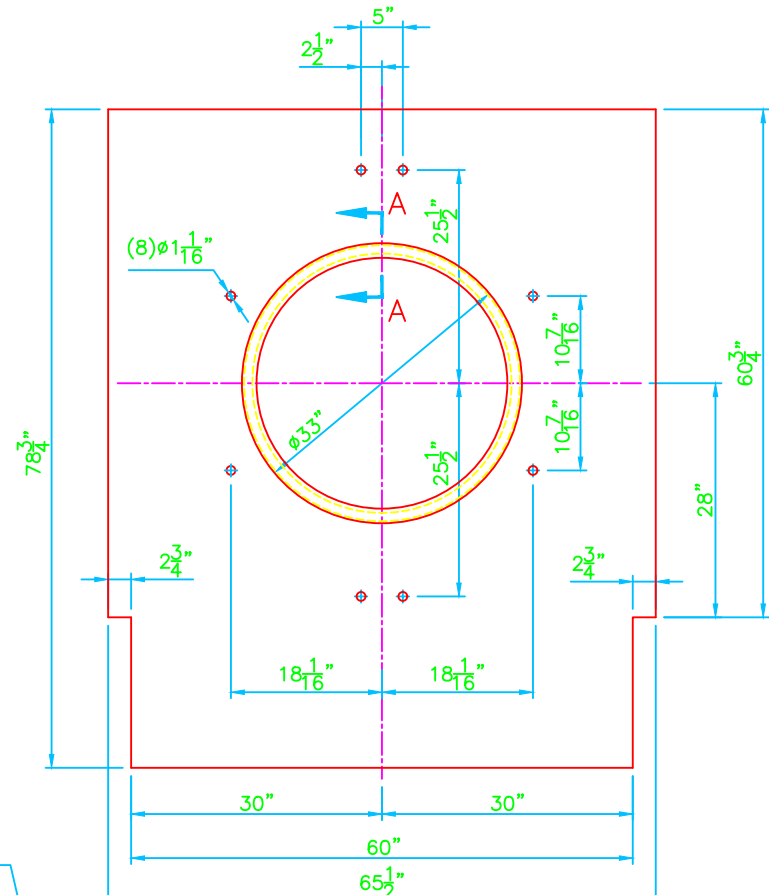

"C" PLATE
1"THK. 304 S.S. PLATE
(6) REQ'D

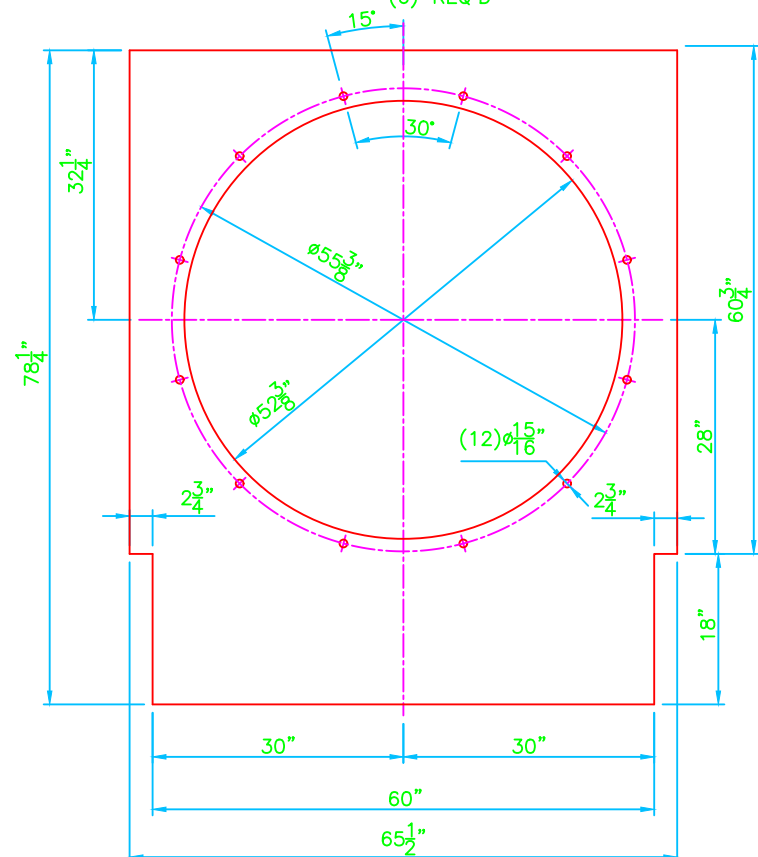

"D" PLATE
1"THK. 304 S.S. PLATE
(6) REQ'D

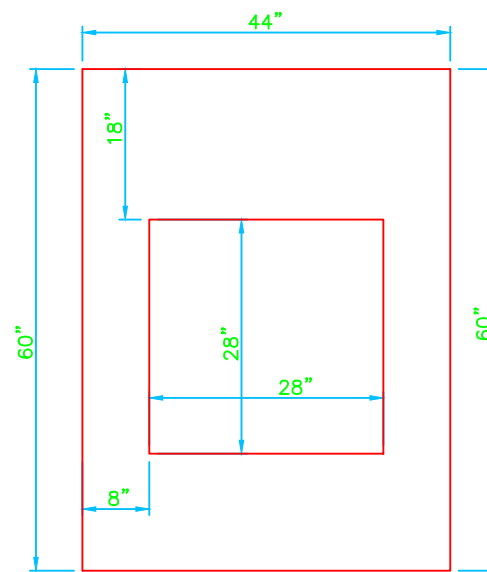

SIDE PLATE
1/2"THK. 304 S.S. PLATE
(12) REQ'D

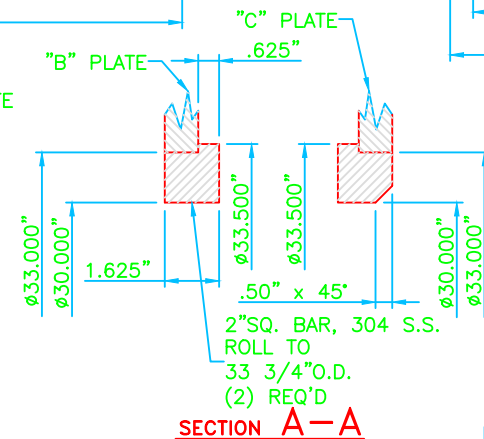

SECTION A-A

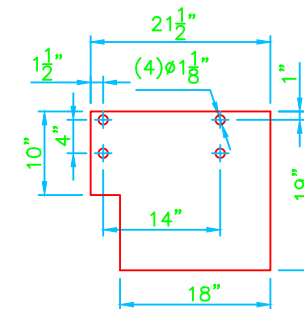

SUPPORT PLATE
1"THK. 304 S.S. PLATE
(12) REQ'D

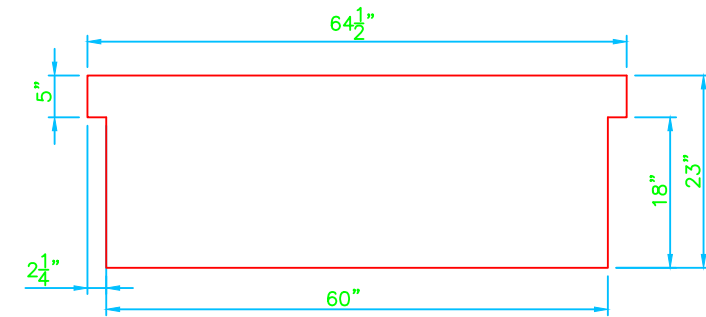

CROSS PLATE
3/4"THK. 304 S.S. PLATE
(6) REQ'D

TOLERANCES UNLESS OTHERWISE SPECIFIED		Vincent CORPORATION TAMPA, FLORIDA	
FRACT.	DECIM.	VP-30 PRESS BED FRAME PARTS DETAILS	
± 1/32	± .004	DRAWING NO. SCALE 3/4" = 1'-0"	
APPROVALS	DATE	DRAWING NO. 1408-16	
DRAWN EG	05/29/07	SHEET	
CHECKED		DO NOT SCALE DWG.	
COMP. NAME 07037 Master		SHEET	
W. O. NO. 07037		SHEET	

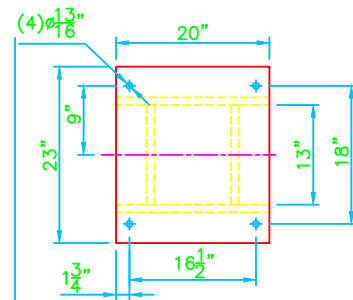

MOTOR PEDESTAL
1" THK. M.S. PLATE

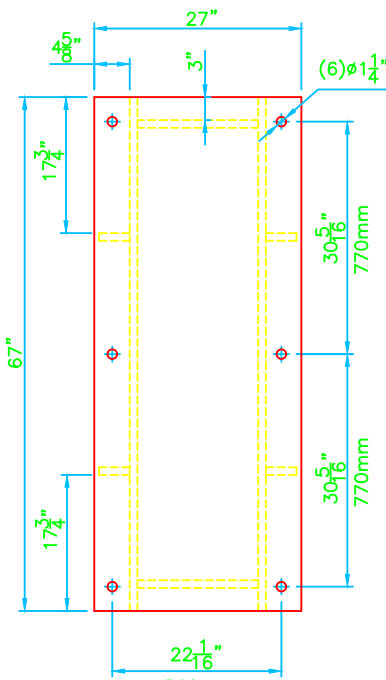

REDUCER PEDESTAL
1 1/2" THK. M.S. PLATE

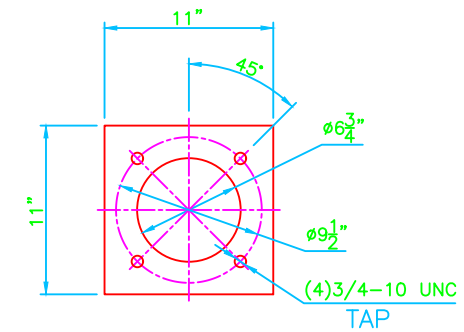
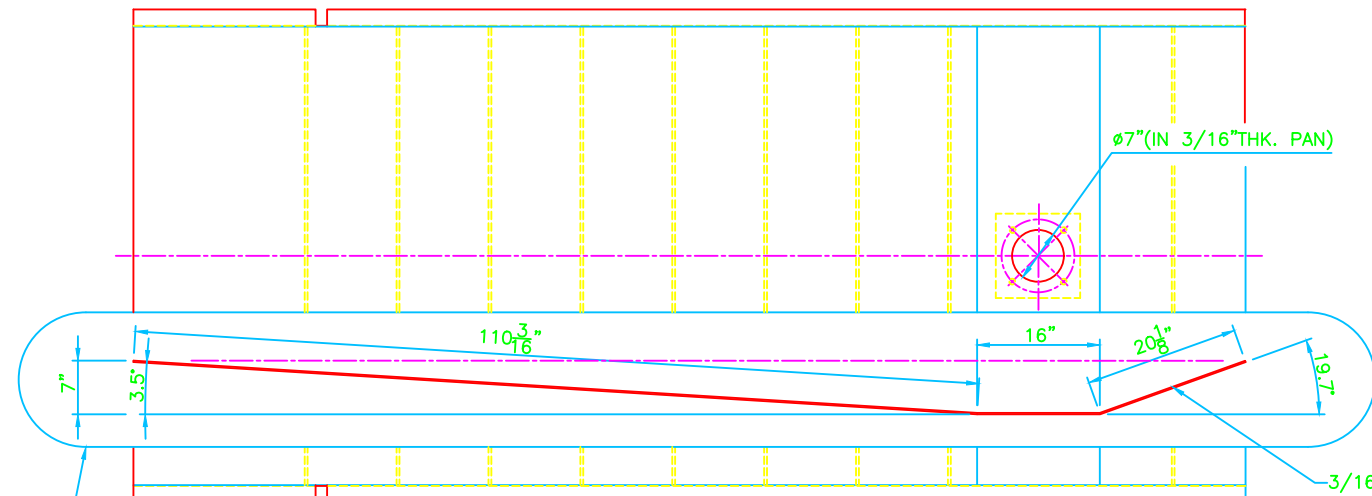
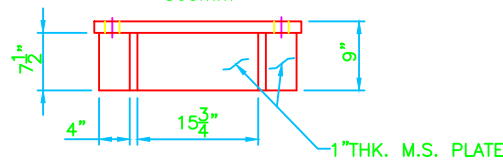

FLANGE
N.T.S.
MAT'L: 1/2" THK. 304 S.S. PLATE

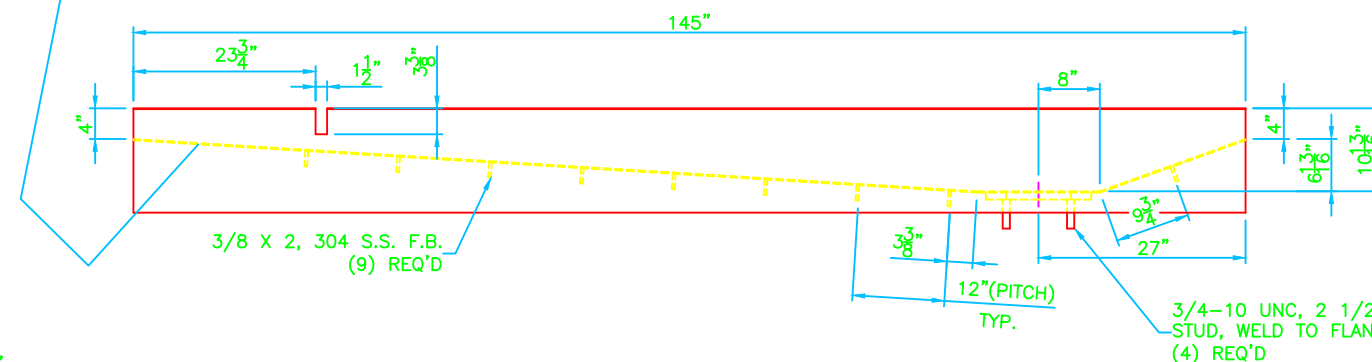

DRAIN PAN ASSEMBLY

NOTE: ALL GIVEN DIMENSIONS ARE NOMINAL AND TO BE VERIFIED AT ASSEMBLY

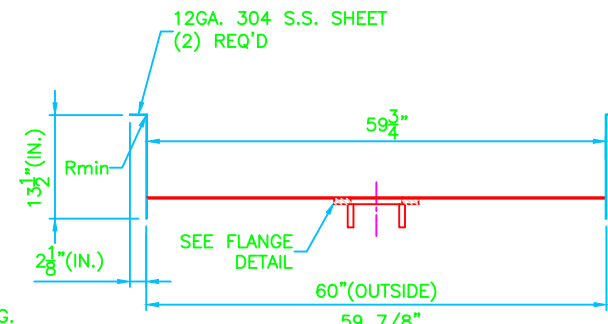

NOTE: ALL GIVEN DIMENSIONS ARE NOMINAL AND TO BE VERIFIED AT ASSEMBLY

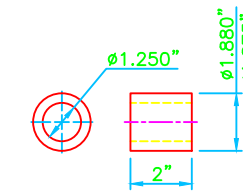

REDUCER BUSHING
N.T.S.
304 S.S.
(6) REQ'D

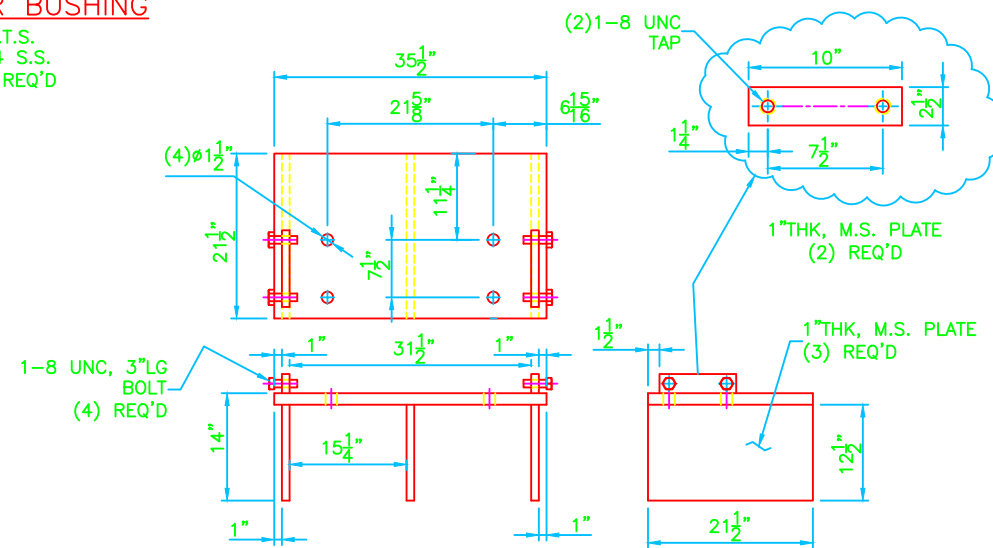

BEARING PEDESTAL
1 1/2" THK. M.S. PLATE

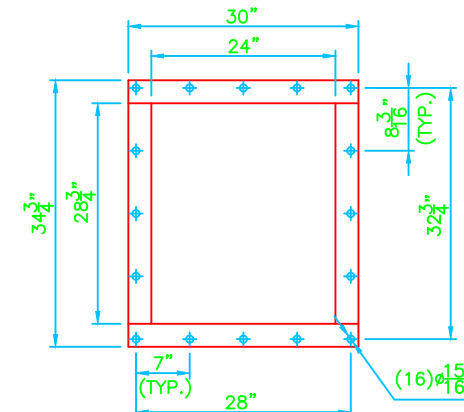

INLET/COMPANION FLANGE
1/2 X 3, 304 S.S. F.B.

TOLERANCES UNLESS OTHERWISE SPECIFIED		Vincent CORPORATION TAMPA, FLORIDA	
FRACT.	DECIM.	ANGUL.	VP-30 PRESS BED FRAME PARTS
± 1/32	± .004	± .5°	SCALE FAC 1/6
APPROVALS	DATE	SIZE	DRAWING NO.
DRAWN EG	05/29/00	C	94281-A
CHECKED		THIS PRINT IS THE PROPERTY OF VINCENT CORPORATION AND IS RECALLABLE AT ANY TIME. IT MUST NOT BE COPIED OR USED DETRIMENTALLY TO OUR INTERESTS.	
COMP. NAME 07037_Master			
NO. 07037	SCALE 3/4" = 1'-0"	DO NOT SCALE DWG.	SHEET

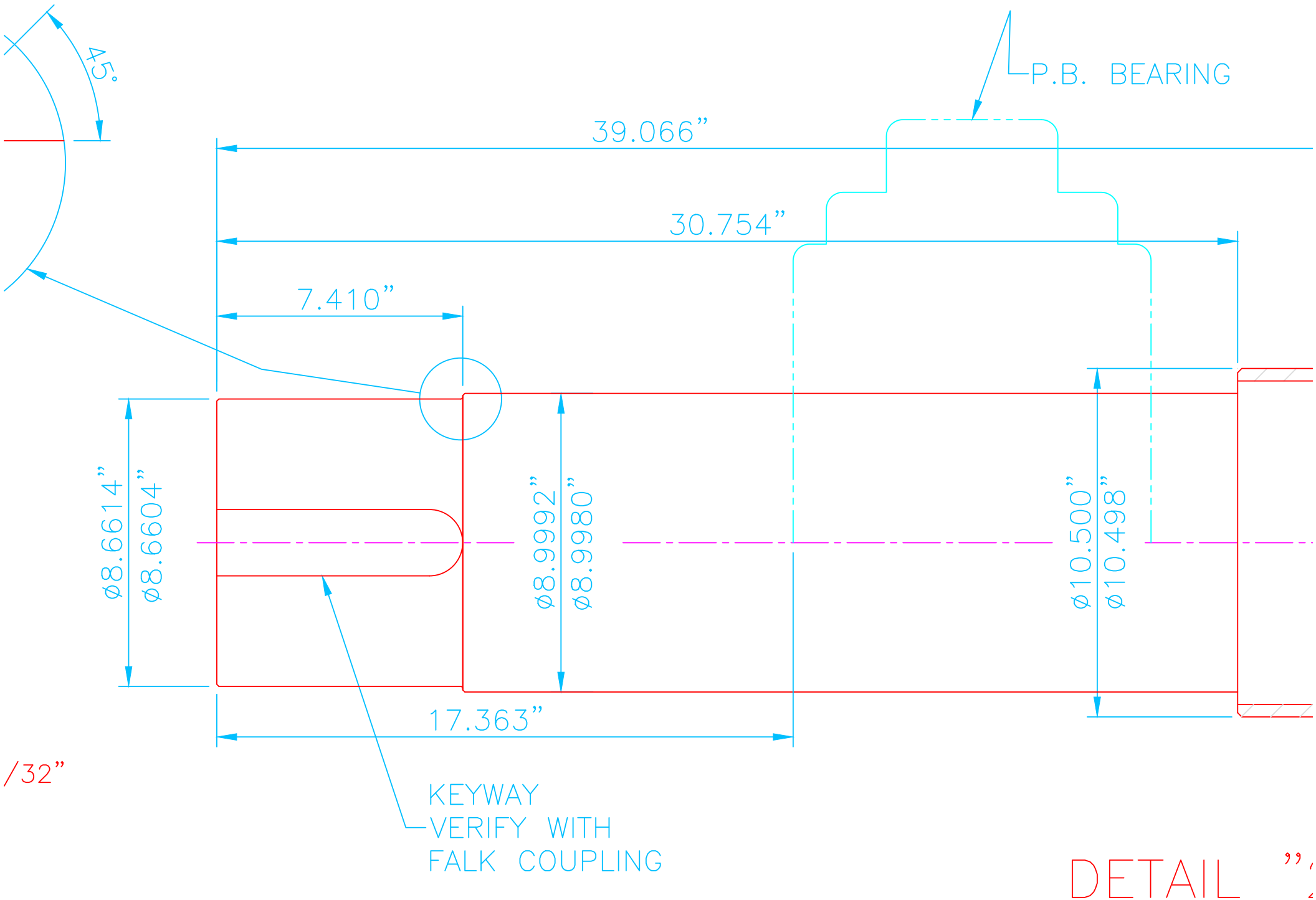

DETAIL

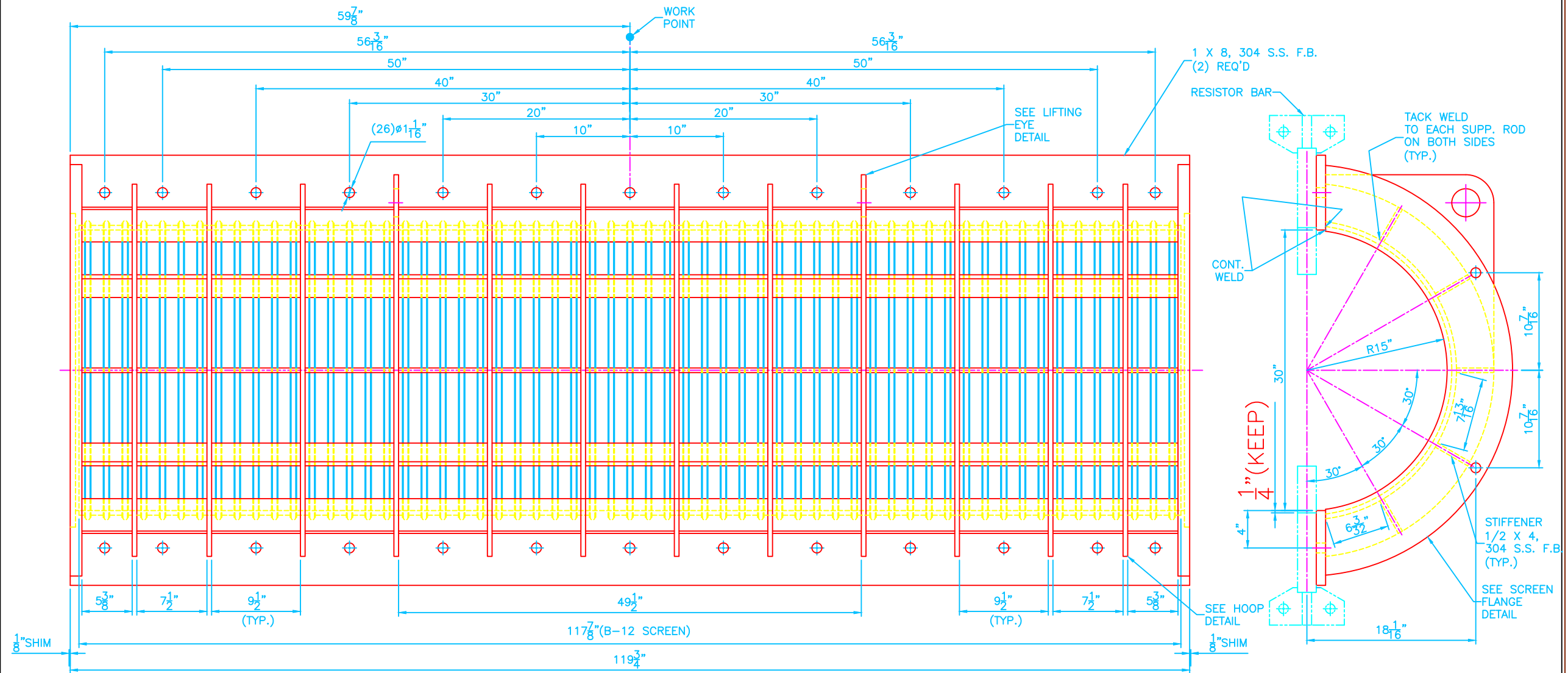

MAIN SCREEN FRAME ASSEMBLY
(2) REQ'D FOR EACH UNIT

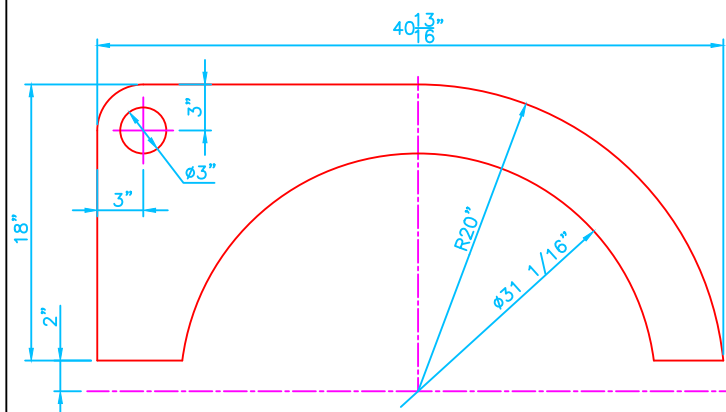

LIFTING EYE
MAT'L: 1/2" THK. 304 S.S. PLATE
(2) REQ'D

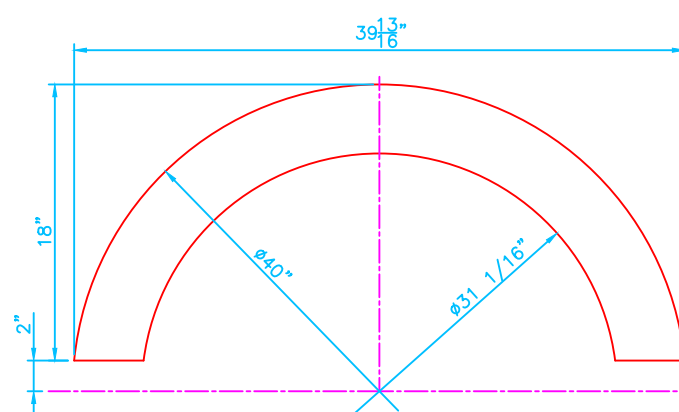

HOOP
MAT'L: 1/2" THK. 304 S.S. PLATE
(10) REQ'D

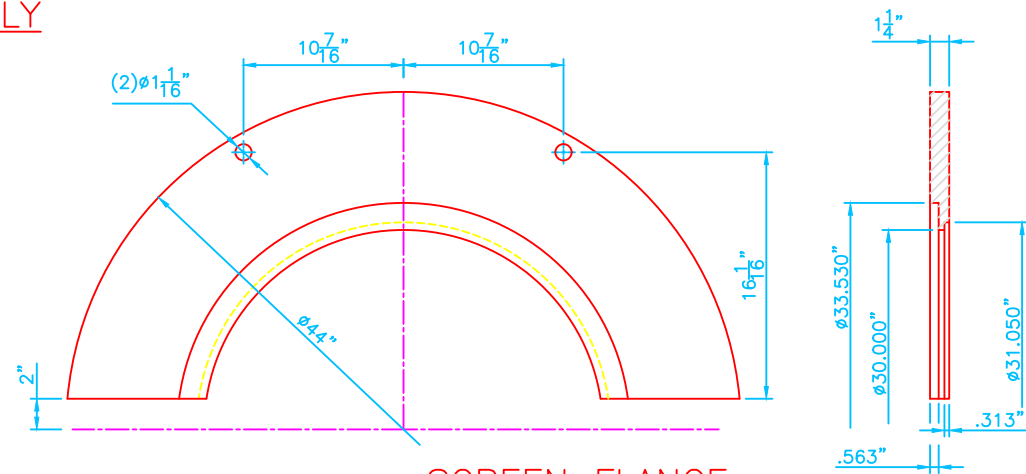

SCREEN FLANGE
MAT'L: 1 1/4" THK. 304 S.S. PLATE
(2) REQ'D

TOLERANCES UNLESS OTHERWISE SPECIFIED		Vincent CORPORATION TAMPA, FLORIDA	
FRACT.	DECIM.	ANGUL.	VP-30 PRESS MAIN SCREEN FRAME ASSEMBLY
± 1/32	± .004	± .5°	SIZE C
APPROVALS	DATE	DRAWING NO. 94284	
DRAWN EG	03/23/07	THIS PRINT IS THE PROPERTY OF VINCENT CORPORATION AND IS RECALLABLE AT ANY TIME. IT MUST NOT BE COPIED OR USED DETRIMENTALLY TO OUR INTERESTS.	
CHECKED		COMP. NAME 07037_Master	SCALE 1-1/2" = 1'-0"
W. O. NO. 07037			DO NOT SCALE DWG. SHEET

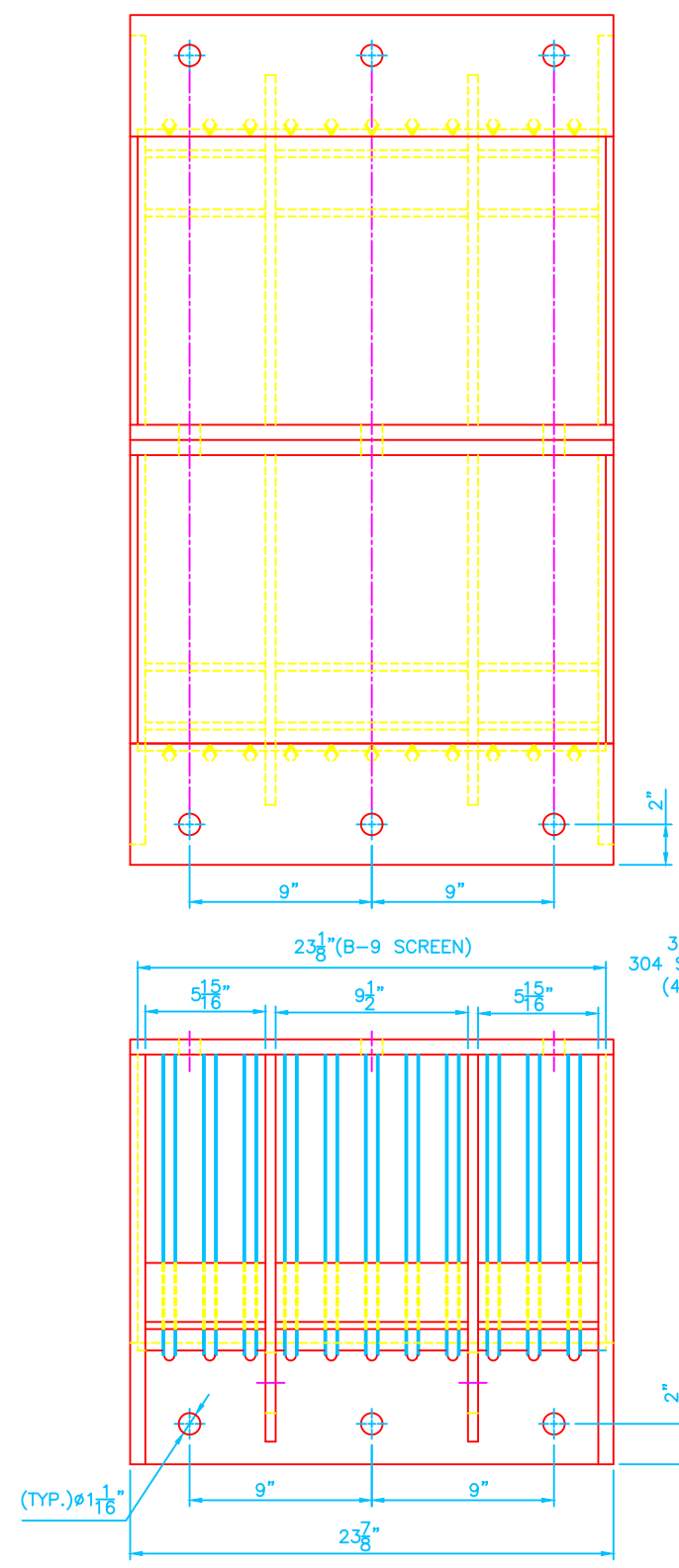

HOPPER SCREEN FRAME ASSEMBLY

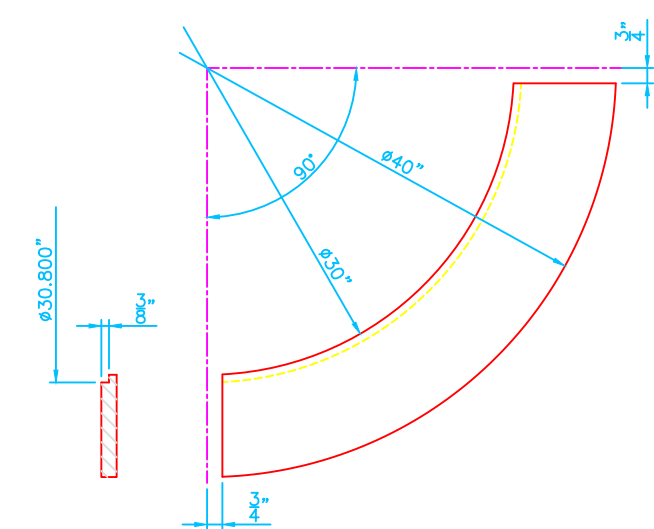
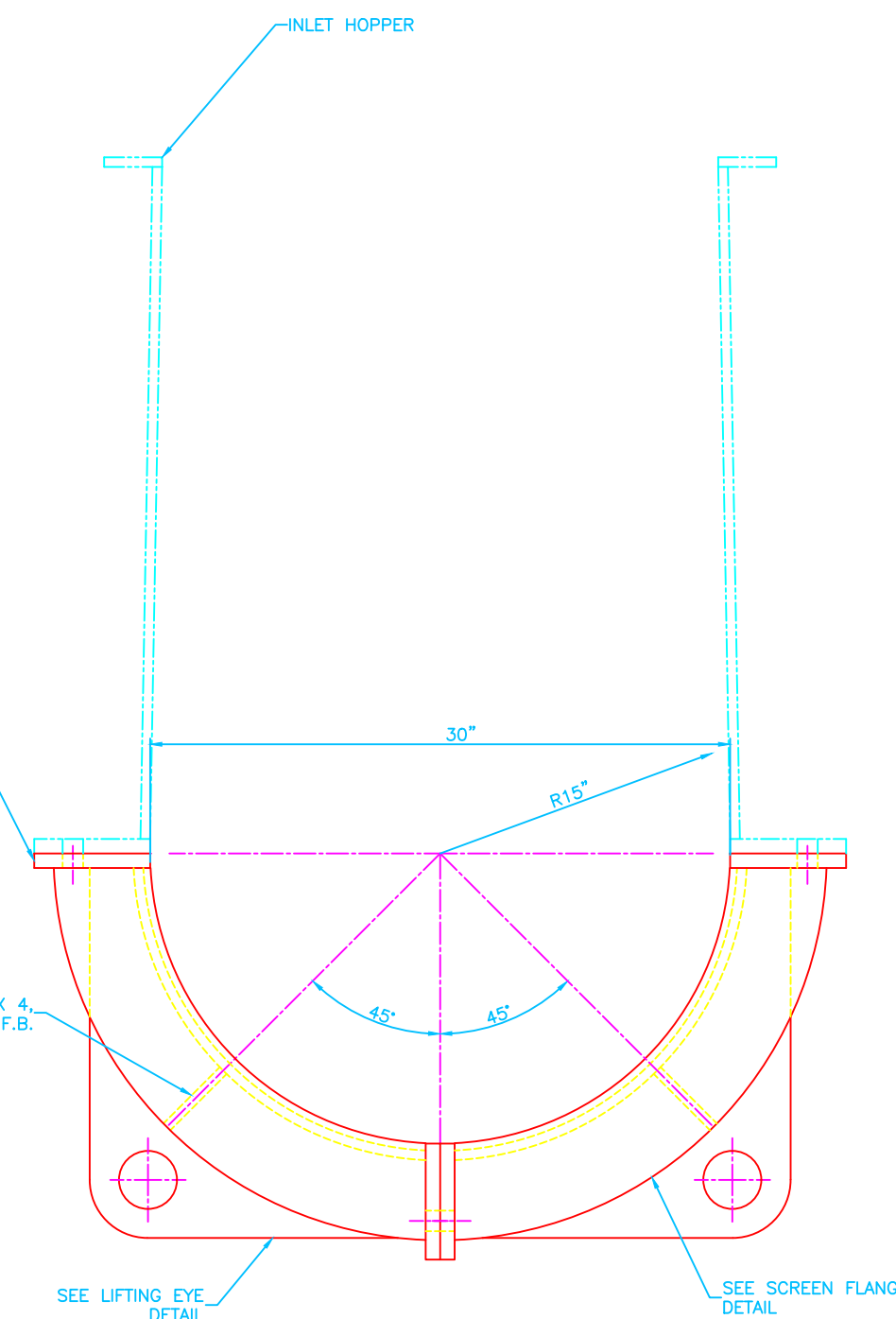

SCREEN FLANGE
MAT'L: 3/4 THK. 304 S.S. PLATE
(4) REQ'D

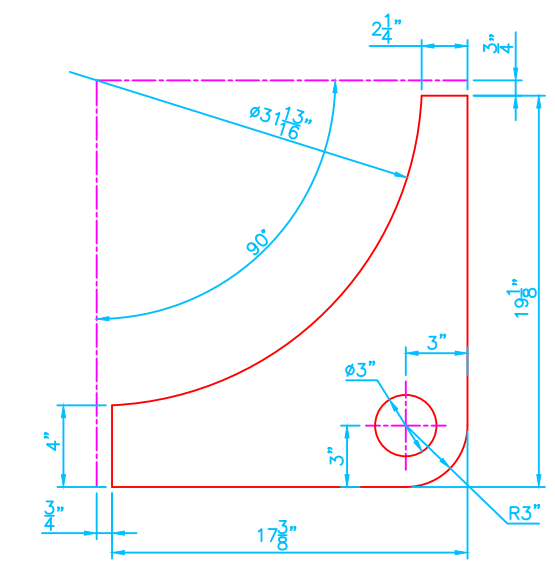

LIFTING EYE
MAT'L: 1/2 THK. 304 S.S. PLATE
(2) REQ'D

TOLERANCES UNLESS OTHERWISE SPECIFIED			Vincent CORPORATION TAMPA, FLORIDA	
FRACT.	DECIM.	ANGUL.	VP-30 PRESS HOPPER SCREEN FRAME ASSEMBLY	
$\pm 1/32$	$\pm .004$	$\pm .5^\circ$	APPROVALS	DATE
			EG	03/23/07
THIS PRINT IS THE PROPERTY OF VINCENT CORPORATION AND IS RECALLABLE AT ANY TIME. IT MUST NOT BE COPIED OR USED DETRIMENTALLY TO OUR INTERESTS.			SIZE	DRAWING NO.
COMP. NAME	07037_Master		C	94285
W. O. NO.	07037	SCALE 2" = 1'-0"	DO NOT SCALE DWG.	SHEET

CONT. WELDT AT
ASSY. IN INLET
HOPPER ONLY

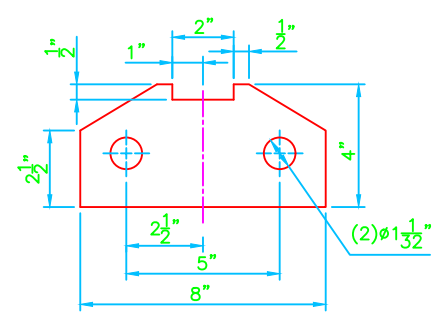
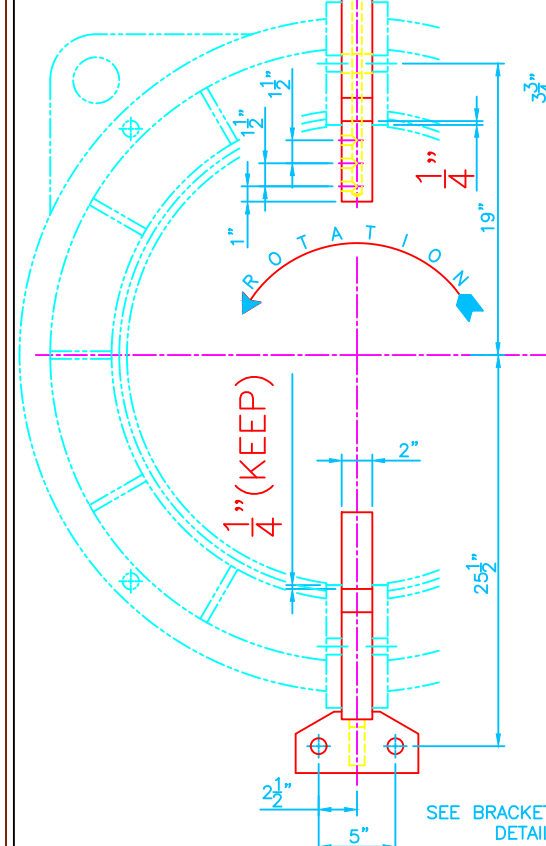
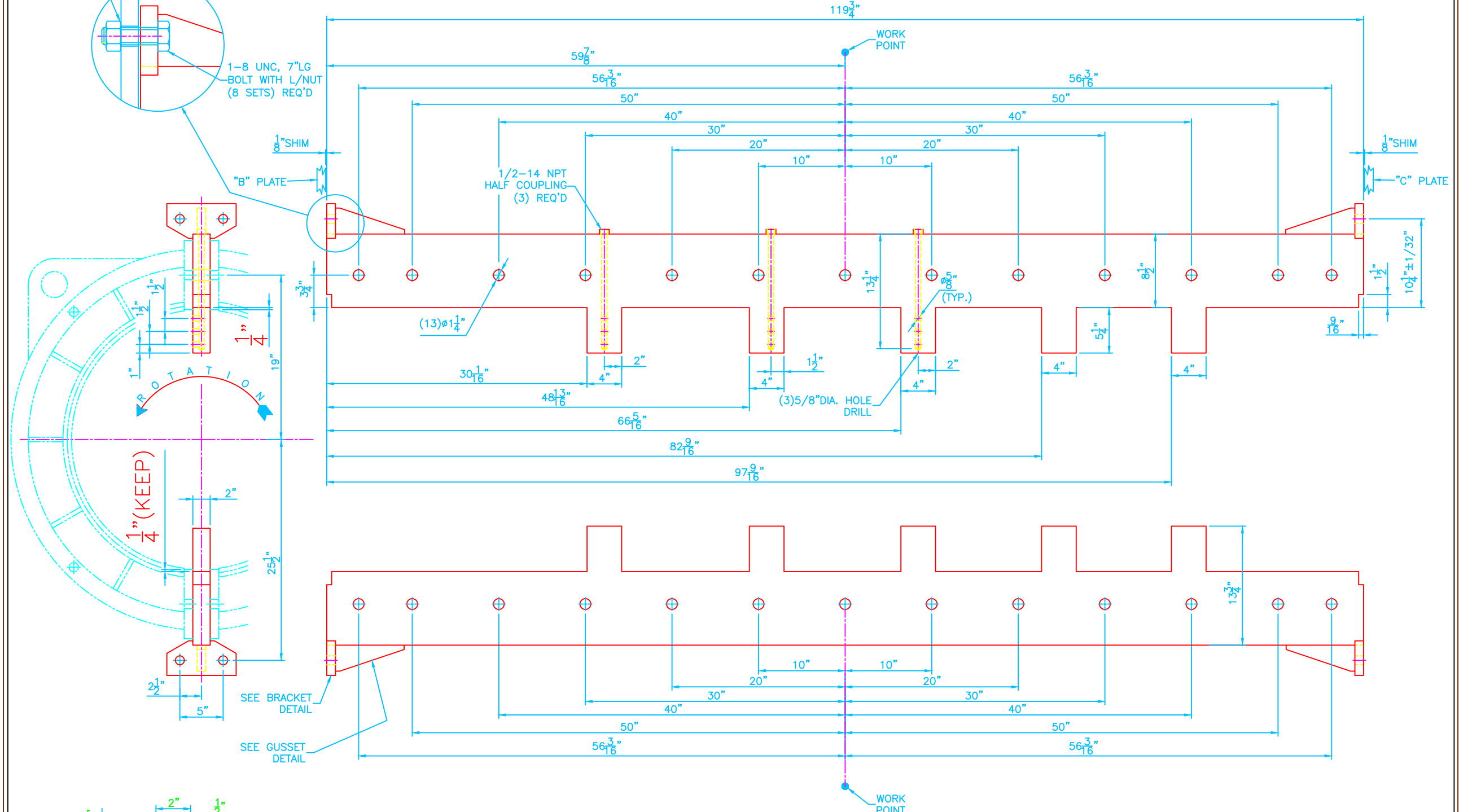

BRACKET

N.T.S.
MAT'L: 1" THK. 304 S.S. PLATE
(4) REQ'D

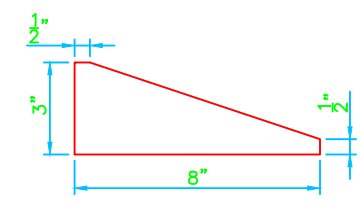

GUSSET

N.T.S.
MAT'L: 1" THK. 304 S.S. PLATE
(4) REQ'D

TOP AND BOTTOM RESISTOR BAR

MAT'L: 2" THK. 304 S.S. PLATE
(2) REQ'D

TOLERANCES UNLESS OTHERWISE SPECIFIED			Vincent CORPORATION TAMPA, FLORIDA	
FRACT.	DECIM.	ANGUL.		
± 1/32	± .004	± .5°	VP-30 PRESS TOP AND BOTTOM RESISTOR BAR ASSEMBLIES	
APPROVALS	DATE	SIZE		
DRAWN EG	03/23/07	C	DRAWING NO. 94286	
CHECKED				
COMP. NAME 07037_Master	THIS PRINT IS THE PROPERTY OF VINCENT CORPORATION AND IS RECALLABLE AT ANY TIME. IT MUST NOT BE COPIED OR USED DETRIMENTALLY TO OUR INTERESTS.			
W. O. NO. 07037	SCALE 1-1/2" = 1'-0"	DO NOT SCALE DWG.	SHEET	

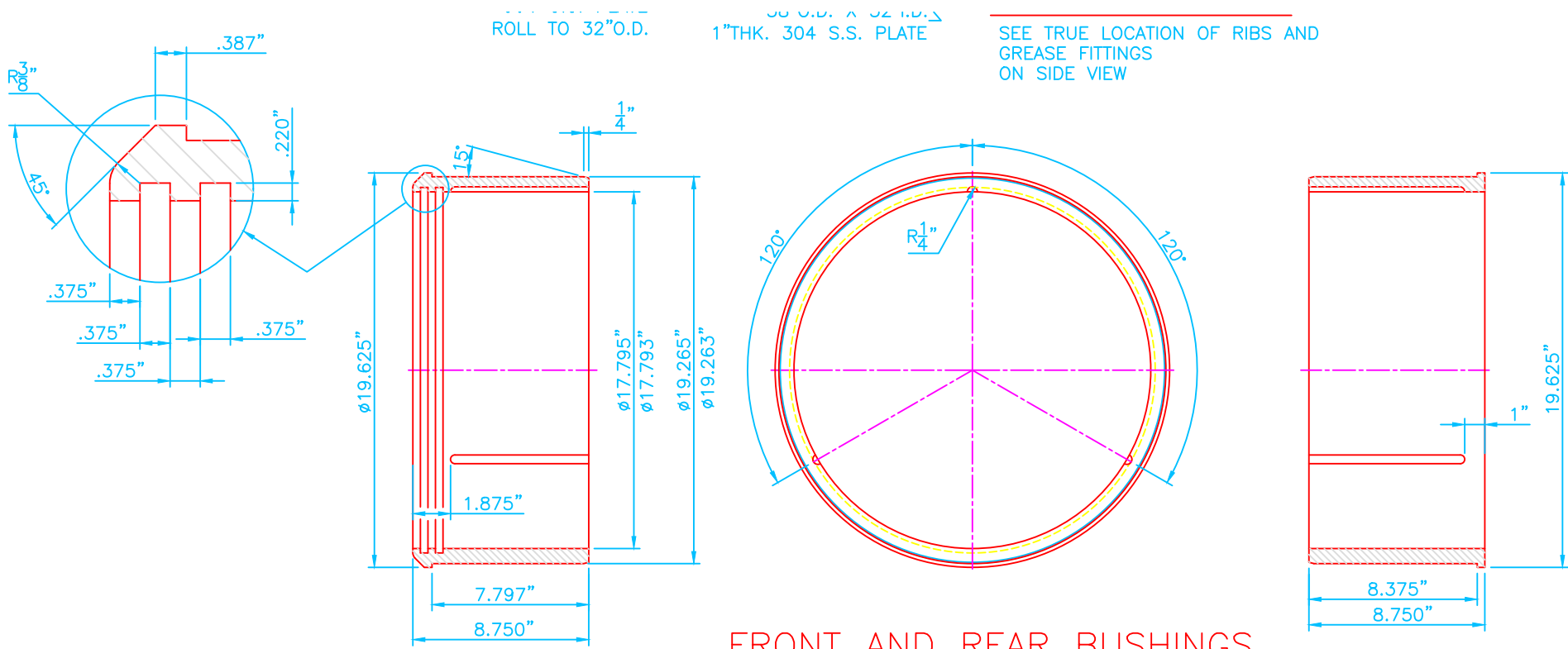

FRONT AND REAR BUSHINGS

MAT'L: 660 BRONZE
 DO NOT MAKE BUSHINGS
 USE FOR REFERENCE
 ONLY

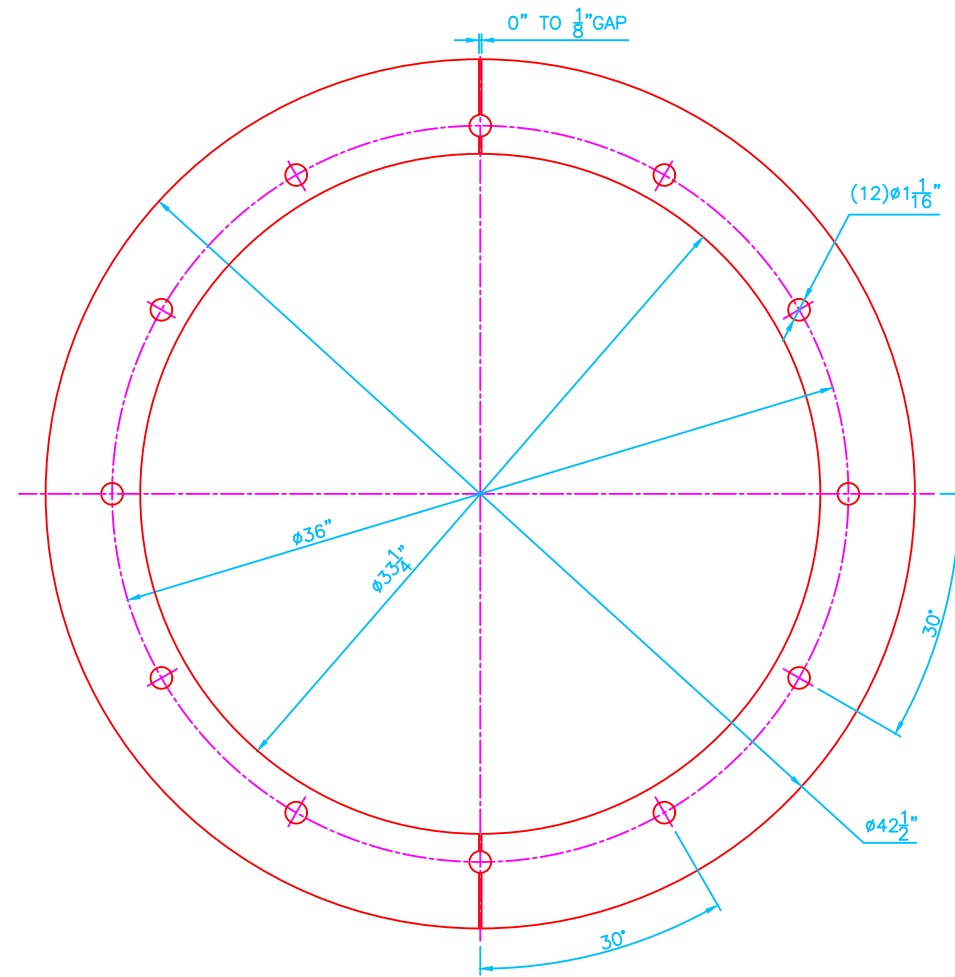

RACING RING
MAT'L: 1" THK. 304 S.S. PLATE

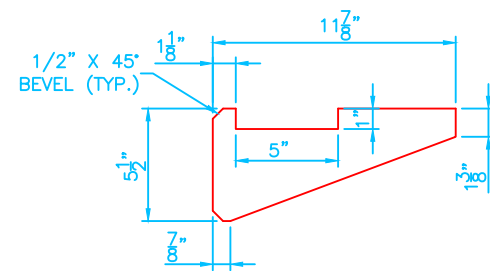

OUTER RIB
MAT'L: 5/8" THK, 304 S.S. PLATE
(5) REQ'D

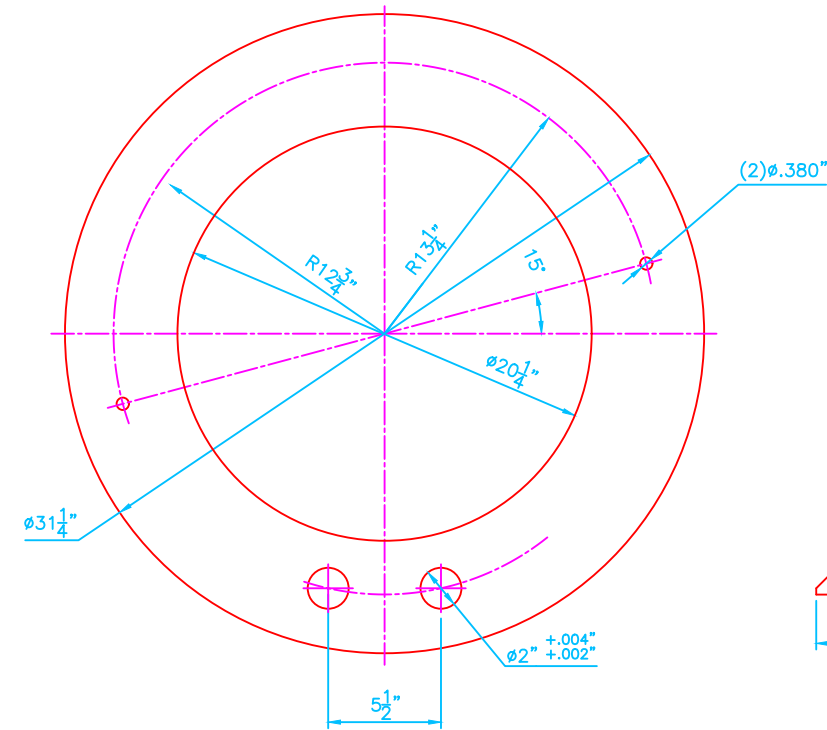

INNER RING
MAT'L: 5/8" THK. 304 S.S. PLATE

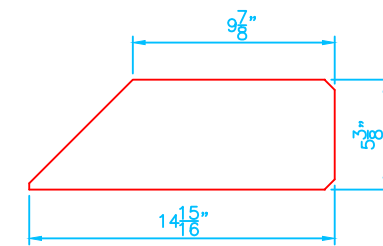

INNER RIB
MAT'L: 3/8" THK, 304 S.S. PLATE
(6) REQ'D

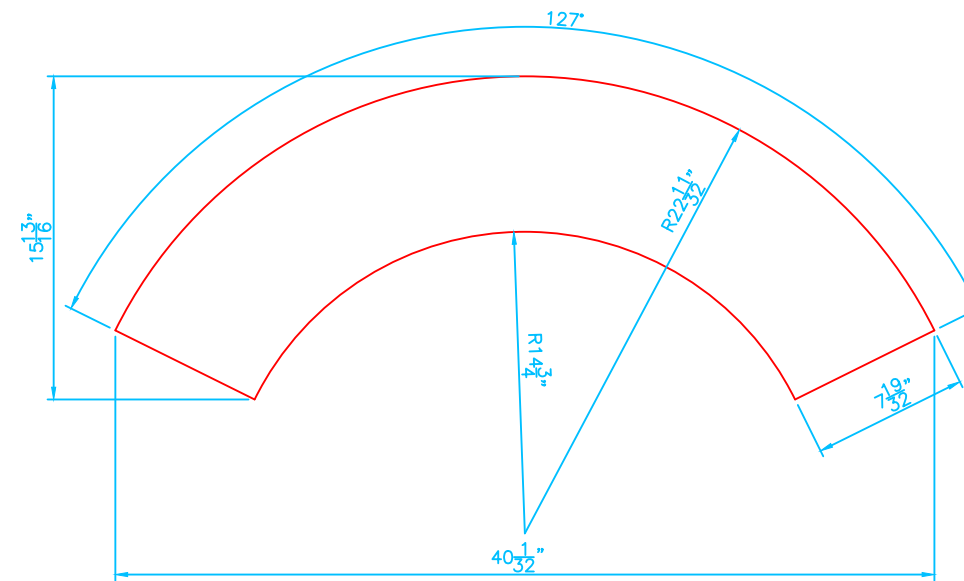

CONE DEVELOPMENT
MAT'L: 1/2" THK, 304 S.S. PLATE
(2) REQ'D

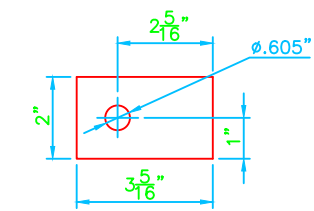

BRACKET
N.T.S.
MAT'L: 3/8 x 2, 304 S.S. F.B.
(2) REQ'D

TOLERANCES UNLESS OTHERWISE SPECIFIED			Vincent CORPORATION TAMPA, FLORIDA	
FRACT.	DECIM.	ANGUL.		
± 1/32	± .004	± .5°	SIZE C	
APPROVALS	DATE	THIS PRINT IS THE PROPERTY OF VINCENT CORPORATION AND IS RECALLABLE AT ANY TIME. IT MUST NOT BE COPIED OR USED DETRIMENTALLY TO OUR INTERESTS.		DRAWING NO. 94288
DRAWN EG	03/23/07	COMP. NAME 07037_Master		SCALE 2" = 1'-0"
CHECKED		W. O. NO. 07037		DO NOT SCALE DWG. SHEET

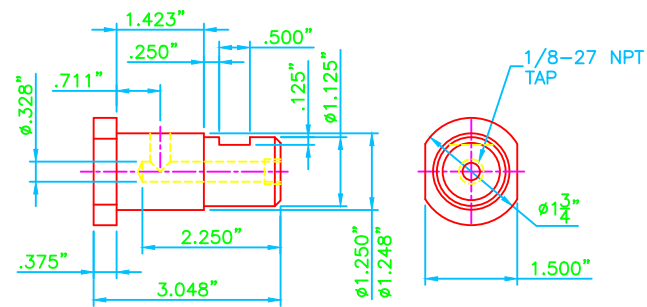
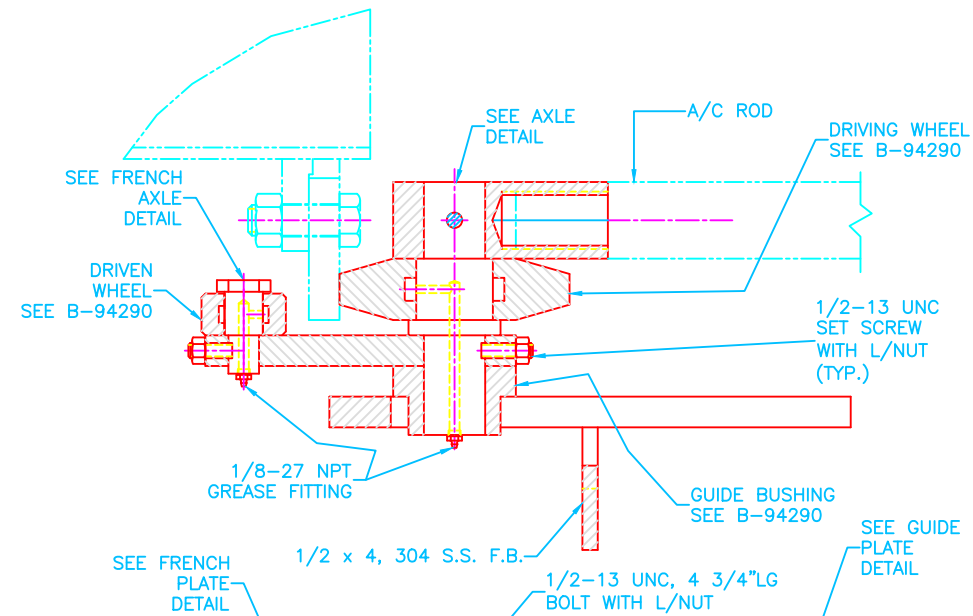

FRENCH AXLE

N.T.S.
 MAT'L: 1 3/4" DIA. 304 S.S. ROD
 (2) REQ'D

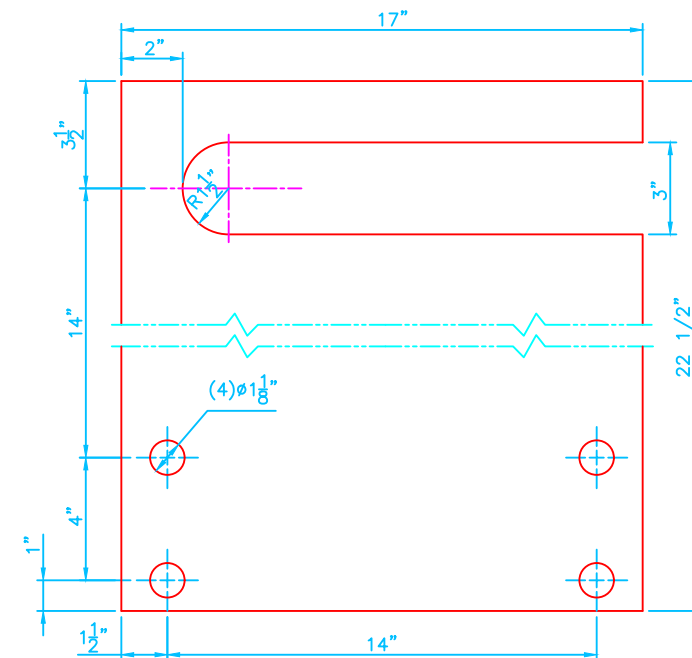

GUIDE PLATE

MAT'L: 1" THK. 304 S.S. PLATE
 (2) REQ'D

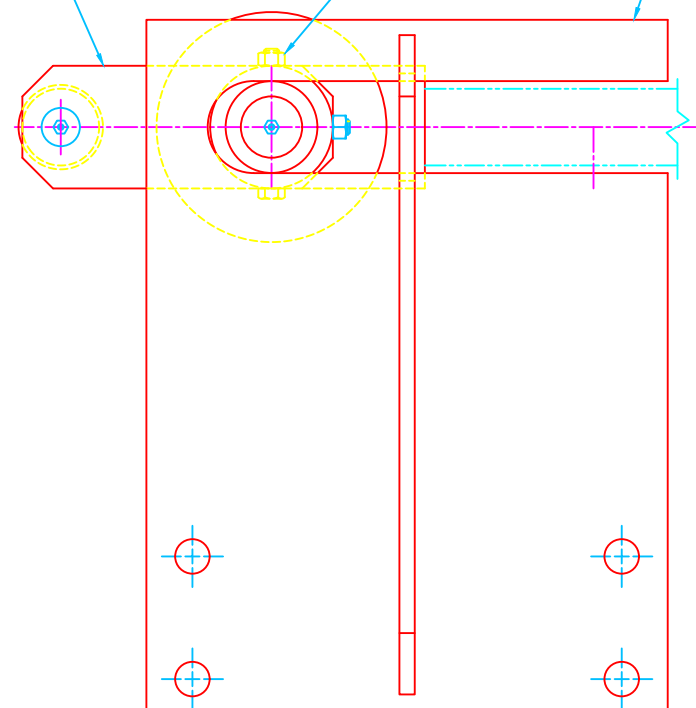

CONE DRIVE MECHANISM

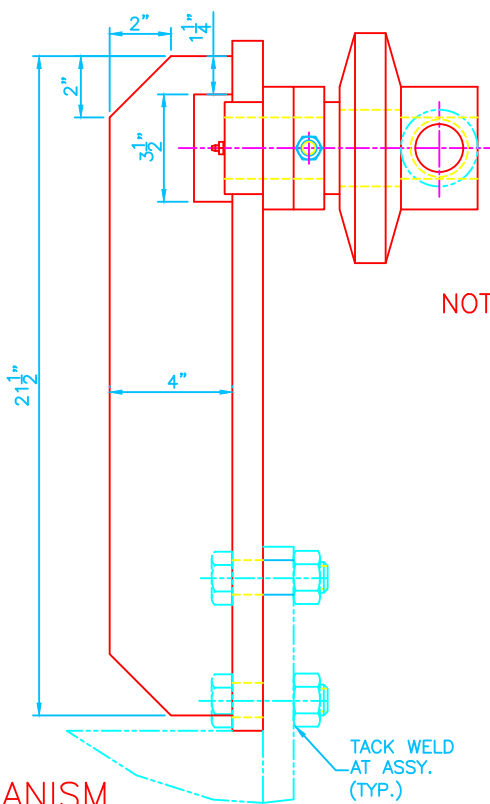

NOTE:
 BREAK ALL SHARP EDGES WITH 1/32" X 45° CHAMFER

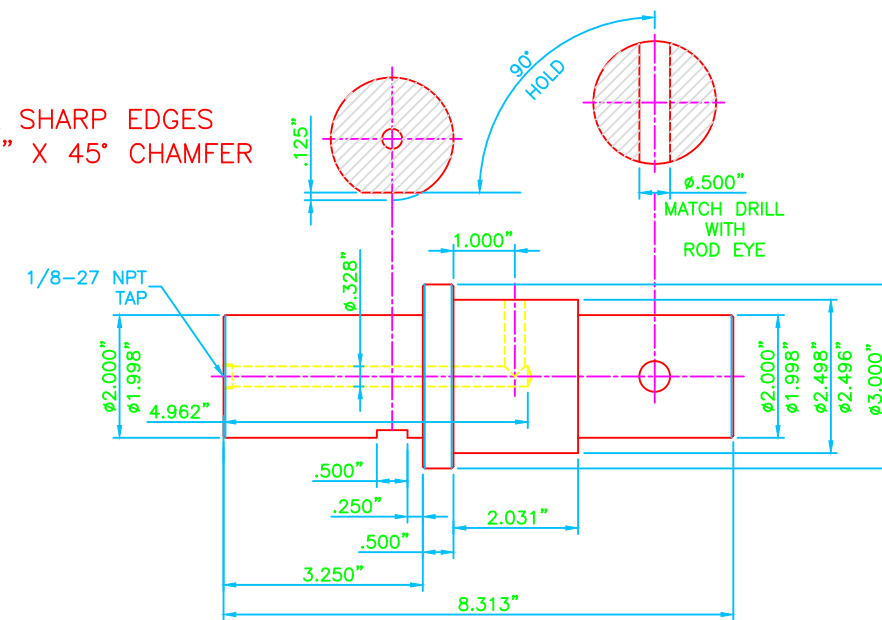

AXLE

N.T.S.
 MAT'L: 3" DIA. 304 S.S. ROD
 (2) REQ'D

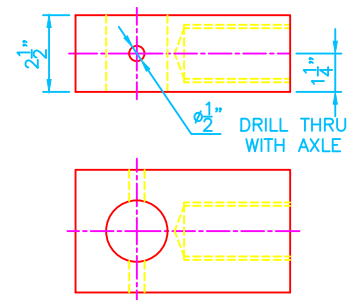

ROD EYE MODIFICATION

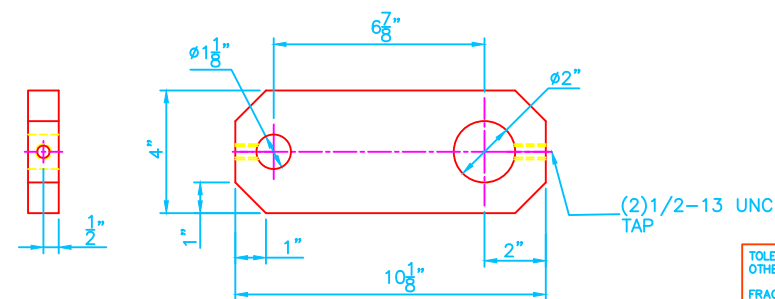

FRENCH PLATE

MAT'L: 1" THK. 304 S.S. PLATE
 (2) REQ'D

TOLERANCES UNLESS OTHERWISE SPECIFIED		
FRACT.	DECIM.	ANGUL.
$\pm 1/32$	$\pm .004$	$\pm .5^\circ$
APPROVALS	DATE	
DRAWN EG	03/23/07	
CHECKED		
COMP. NAME 07037_Master	THIS PRINT IS THE PROPERTY OF VINCENT CORPORATION AND IS RECALLABLE AT ANY TIME. IT MUST NOT BE COPIED OR USED DETRIMENTALLY TO OUR INTERESTS.	
W. O. NO. 07037	SCALE 3" = 1'-0"	DO NOT SCALE DWG.

Vincent CORPORATION		TAMPA, FLORIDA	
VP-30 PRESS CONE DRIVE MECHANISM ASSEMBLY			
SIZE C	DRAWING NO. 94289	THIS PRINT IS THE PROPERTY OF VINCENT CORPORATION AND IS RECALLABLE AT ANY TIME. IT MUST NOT BE COPIED OR USED DETRIMENTALLY TO OUR INTERESTS.	
SCALE 3" = 1'-0"		DO NOT SCALE DWG.	SHEET

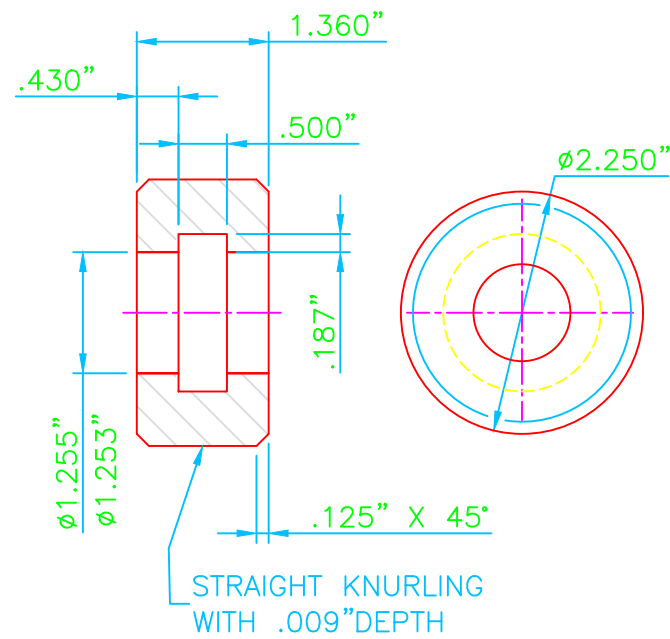

DRIVEN WHEEL

N.T.S.
 MAT'L: C86300 MANGANESE BRONZE
 (2) REQ'D

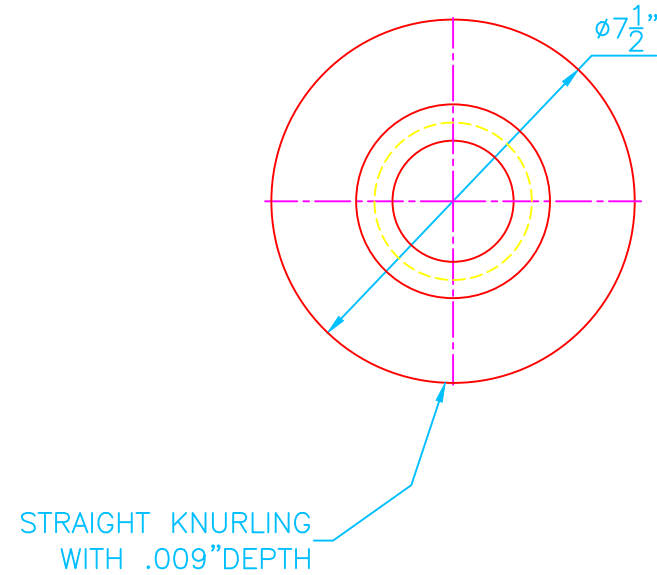

DRIVING WHEEL

N.T.S.
 MAT'L: C86300 MANGANESE BRONZE
 (2) REQ'D

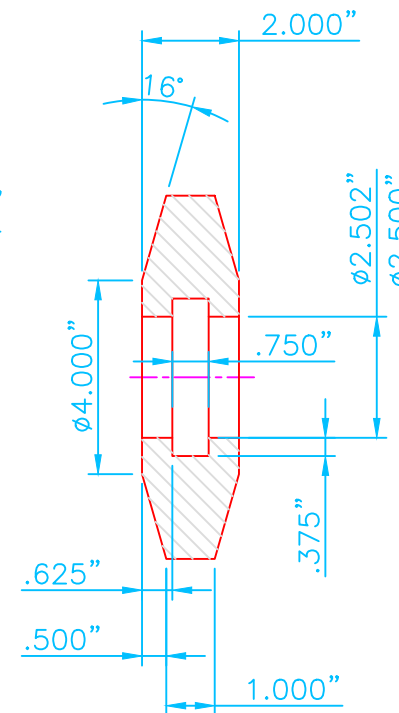

GUIDE BUSHING

N.T.S.
 MAT'L: 600 BEARING BRONZE
 (2) REQ'D

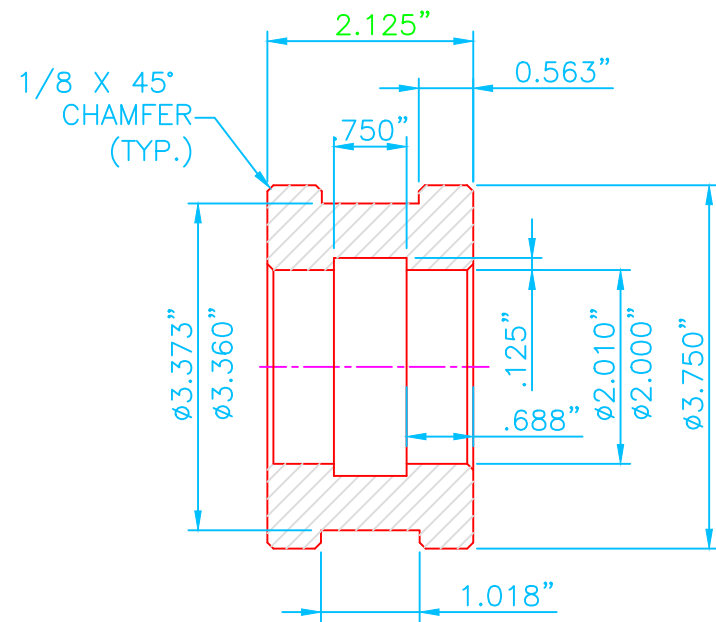

CLUTCH WHEEL

N.T.S.
 MAT'L: C86300 MANGANESE BRONZE
 (2) REQ'D

DO NOT MAKE PARTS
 USE FOR REFERENCE
 ONLY

TOLERANCES UNLESS OTHERWISE SPECIFIED			Vincent CORPORATION TAMPA, FLORIDA	
FRACT.	DECIM.	ANGUL.		
± 1/32	± .004	± .5°	VP-30 PRESS CONE DRIVE MECHANISM PARTS DETAILS	
APPROVALS	DATE			
DRAWN	EG	03/23/07		THIS PRINT IS THE PROPERTY OF VINCENT CORPORATION AND IS RECALLABLE AT ANY TIME. IT MUST NOT BE COPIED OR USED DETRIMENTALLY TO OUR INTERESTS.
CHECKED			SIZE	
COMP. NAME	07037_Master		B	94290
W. O. NO.	07037		SCALE	N. T. S.
			DO NOT SCALE DWG.	SHEET

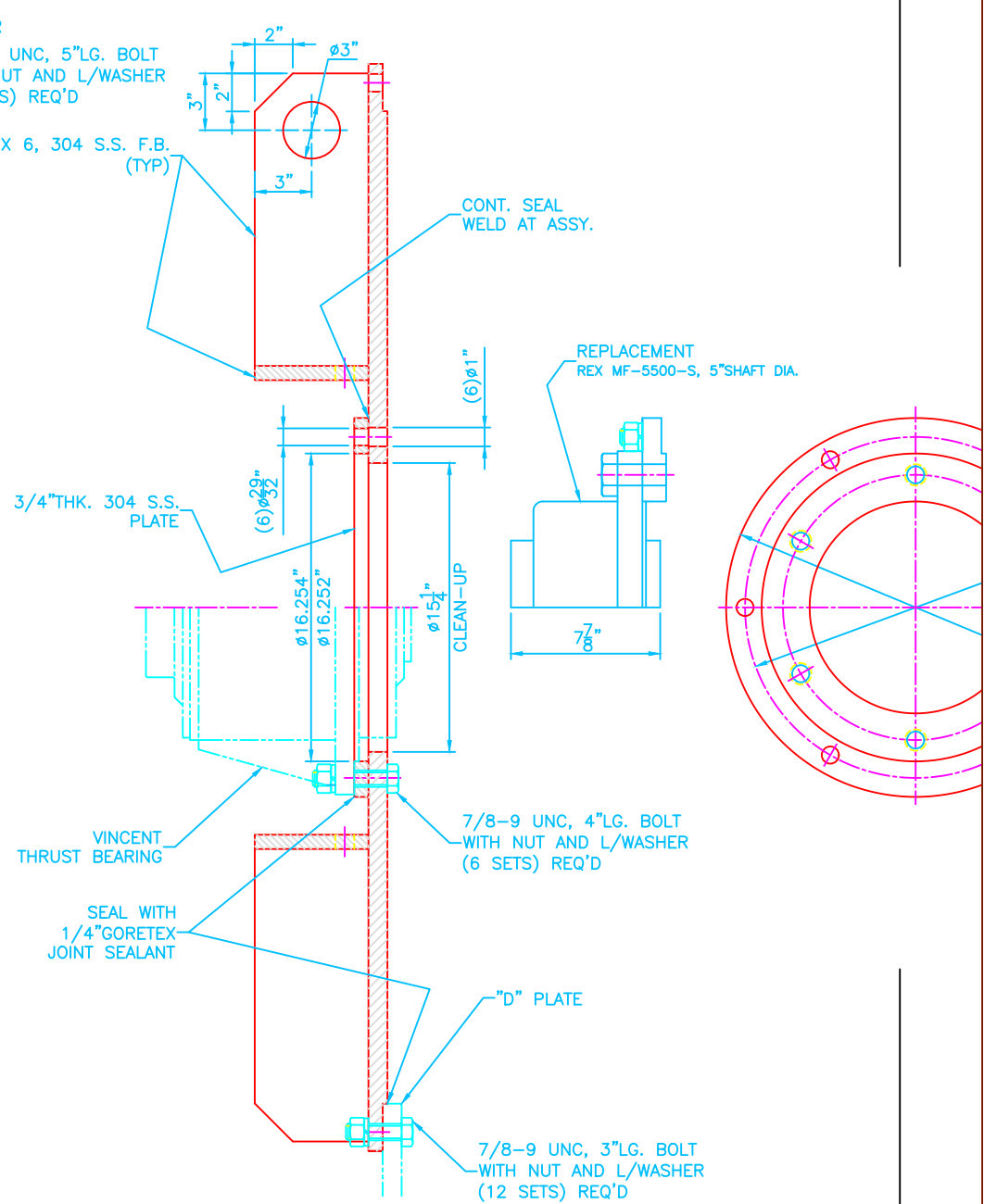
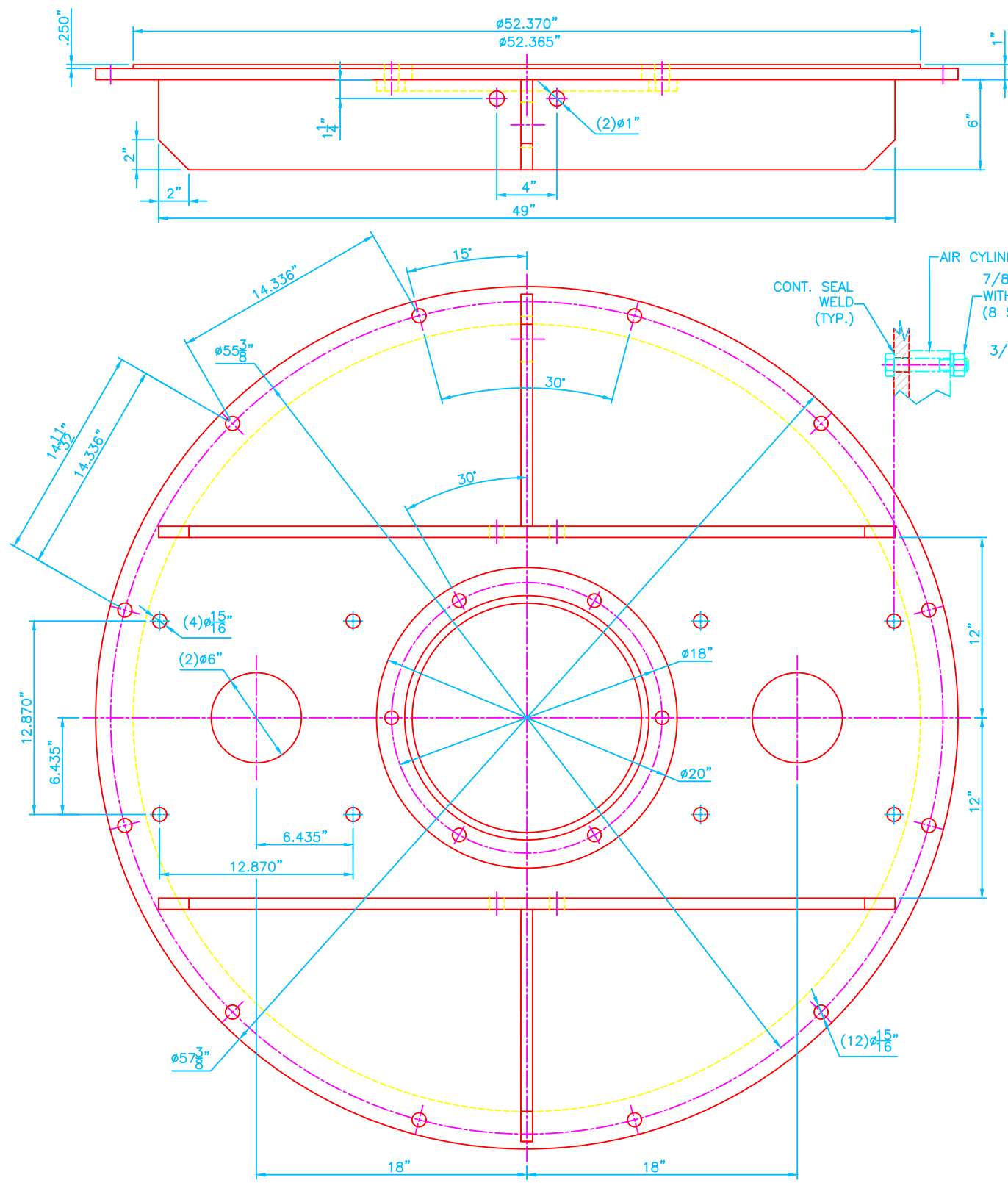

- NOTE:
- 1) ALL MACHINING MUST BE PROVIDED AFTER FABRICATION COMPLETE
 - 2) BREAK SHARP CORNERS WITH 1/32" X 45° CHAMFER AS SHOWN

THRUST FLANGE ASSEMBLY
MAT'L: 1" THK. 304 S.S. PLATE

TOLERANCES UNLESS OTHERWISE SPECIFIED			Vincent CORPORATION TAMPA, FLORIDA	
FRACT.	DECIM.	ANGUL.	VP-30 PRESS THRUST FLANGE ASSEMBLY	
± 1/32	± .004	± .5°		
APPROVALS	DATE	<small>THIS PRINT IS THE PROPERTY OF VINCENT CORPORATION AND IS RECALLABLE AT ANY TIME. IT MUST NOT BE COPIED OR USED DETRIMENTALLY TO OUR INTERESTS.</small>		
DRAWN EG	03/23/07			
CHECKED				
COMP. NAME 07037_Master				
W. O. NO. 07037	SCALE 2" = 1'-0"	DO NOT SCALE DWG.	SIZE B	DRAWING NO. 94292
			SHEET	

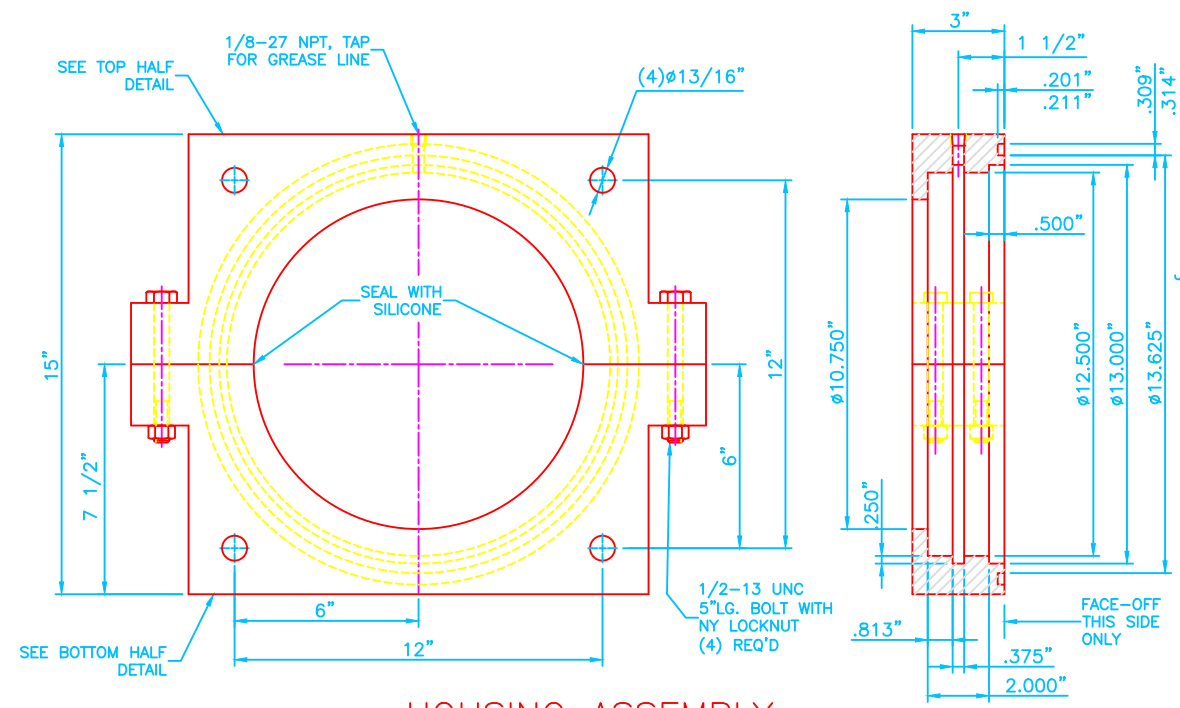

HOUSING ASSEMBLY

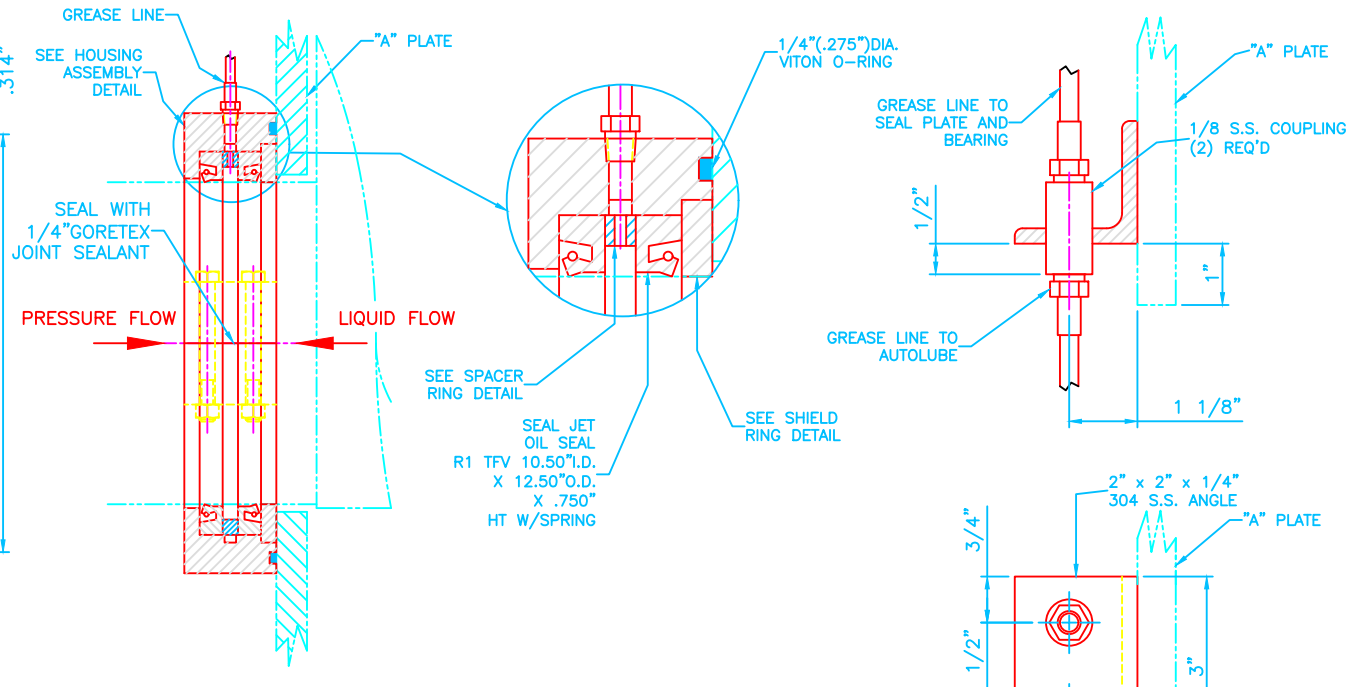

SEAL PLATE ASSEMBLY

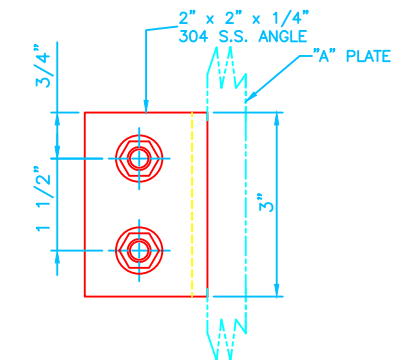

GREASE FITTING BRACKET

N.T.S.

NOTE:
1. ALL SHARP EDGES TO BE REMOVED AFTER MACHINING

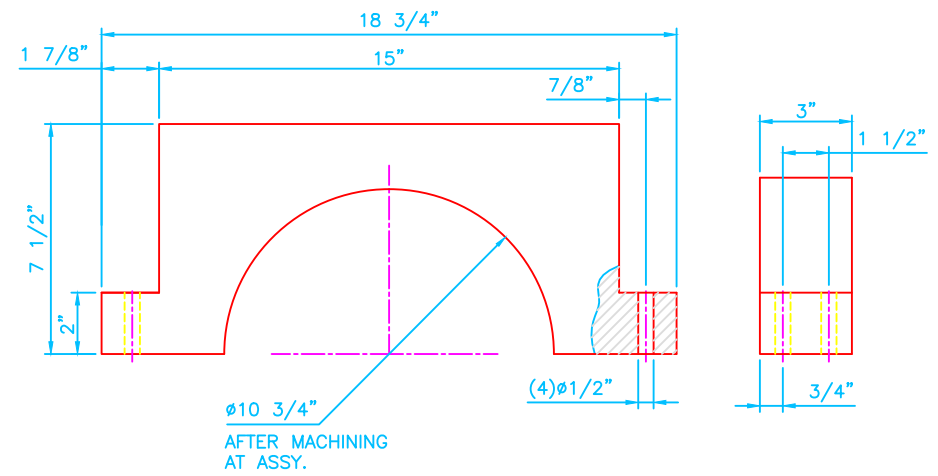

TOP HALF

MAT'L: 3" THK., UHMW PLATE

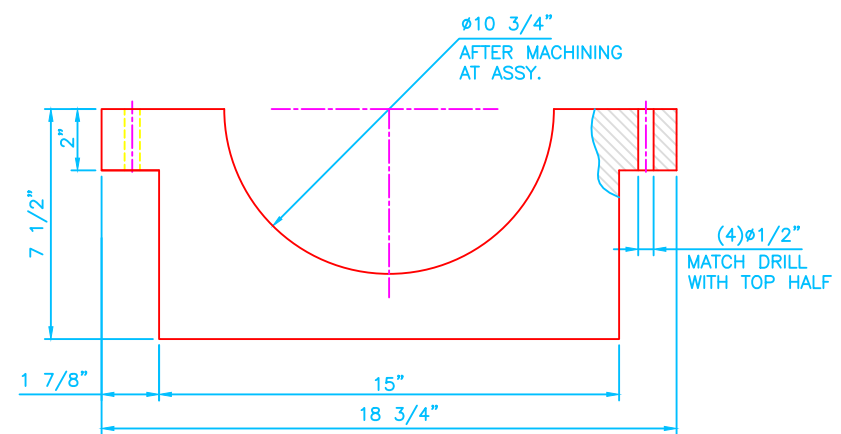

BOTTOM HALF

MAT'L: 3" THK., UHMW PLATE

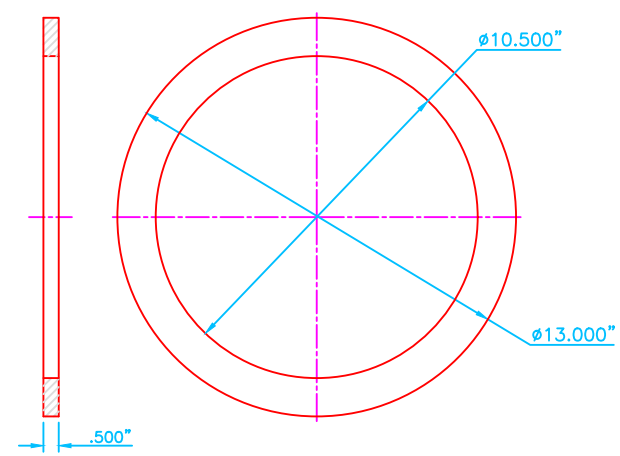

SHIELD RING

MAT'L: UHMW PLATE

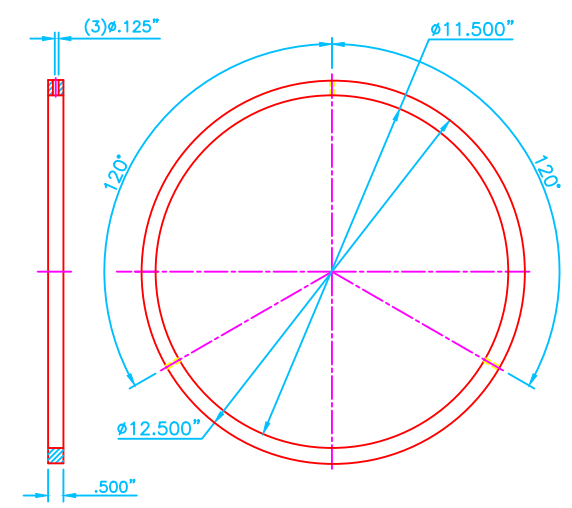

SPACER RING

MAT'L: UHMW PLATE

TOLERANCES UNLESS OTHERWISE SPECIFIED:
DECIMAL FOR MACHINING:
ON SHAFT $-.004$ "
ON HOLE $+.004$ "
OTHERS $\pm .004$ "

TOLERANCES UNLESS OTHERWISE SPECIFIED		Vincent CORPORATION TAMPA, FLORIDA	
FRACT.	DECIM.	ANGUL.	VP-30 PRESS SEAL PLATE ASSEMBLY (DRIVE END)
$\pm 1/32$	$\pm .004$	$\pm .5^\circ$	SIZE C
APPROVALS	DATE	DRAWING NO. 94293	
DRAWN EG	03/23/07	THIS PRINT IS THE PROPERTY OF VINCENT CORPORATION AND IS RECALLABLE AT ANY TIME. IT MUST NOT BE COPIED OR USED DETRIMENTALLY TO OUR INTERESTS.	
CHECKED		COMP. NAME 07037_Master	W. O. NO. 07037
SCALE 3" = 1'-0"		DO NOT SCALE DWG.	SHEET

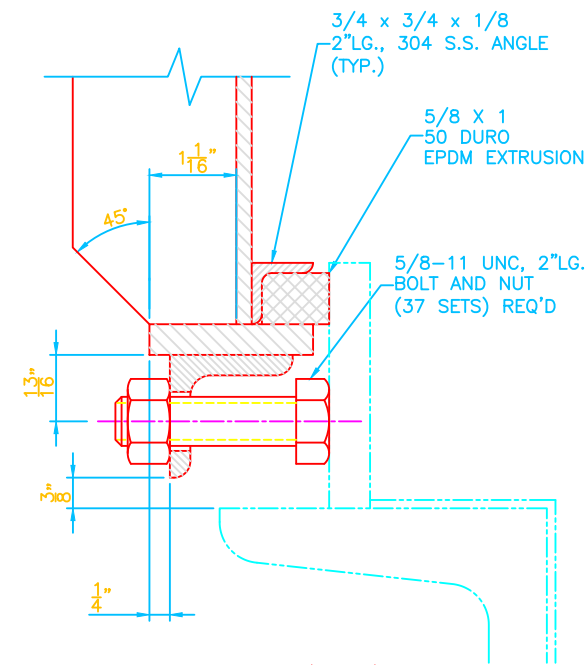
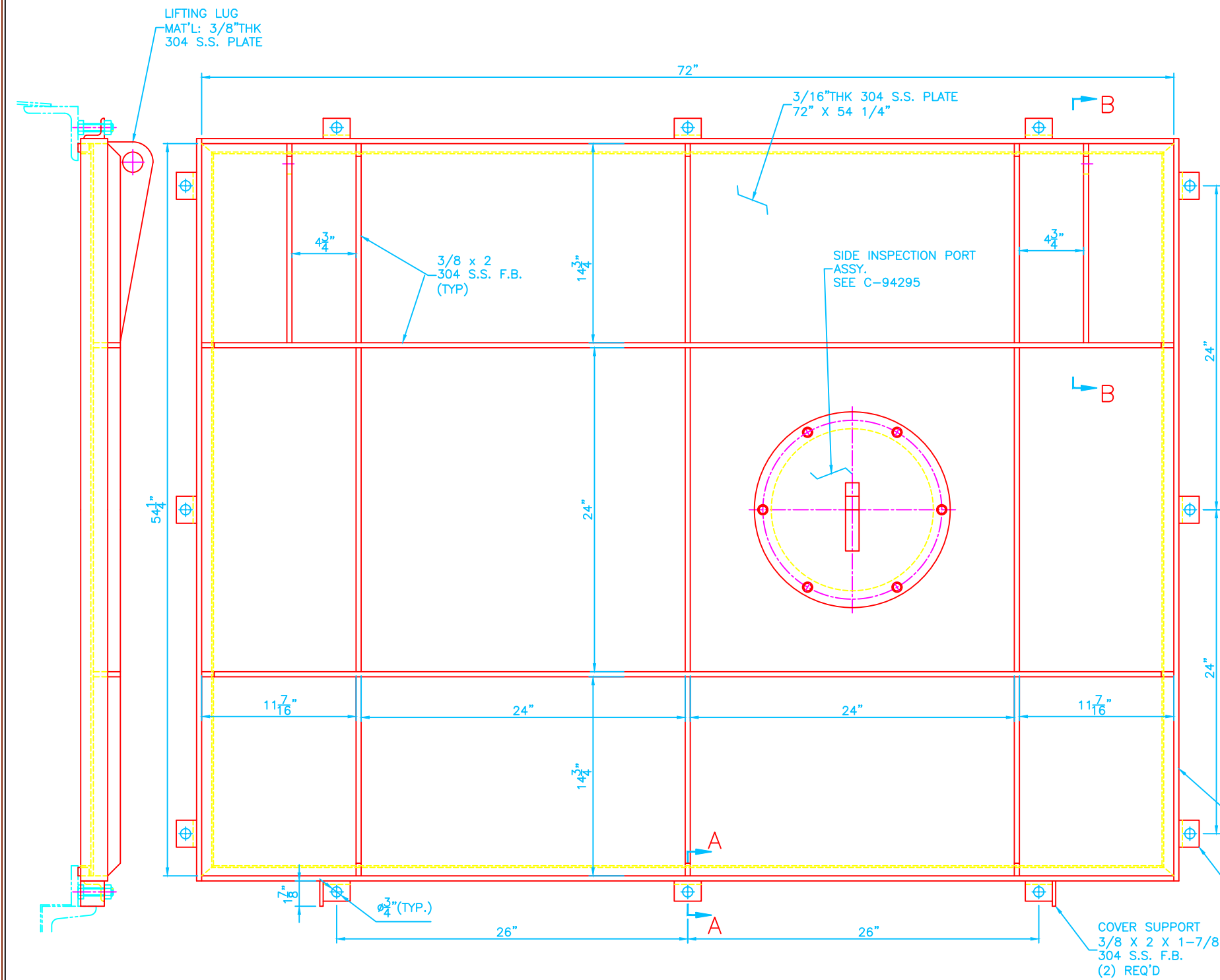

SECTION A-A
N.T.S.

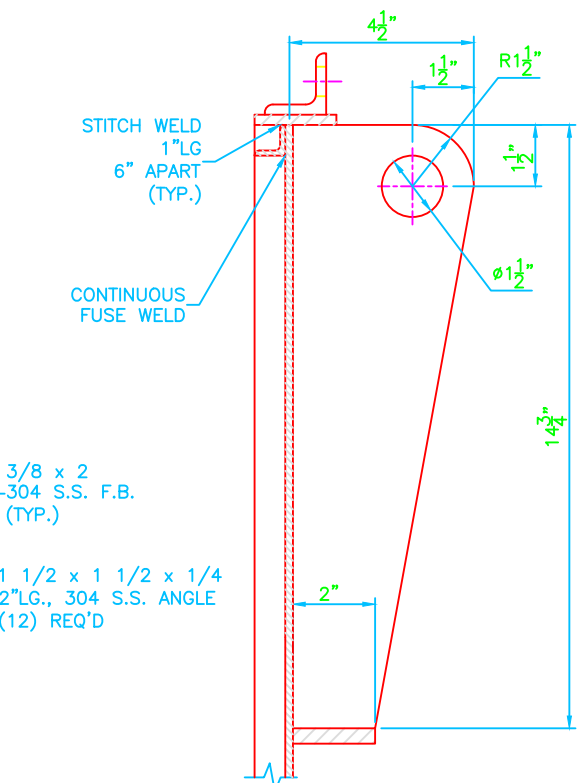

SECTION B-B
N.T.S.

VAPOR TIGHT RIGHT SIDE COVERS

- (1) REQ'D WITH SIDE INSPECTION PORT
- (1) REQ'D WITHOUT SIDE INSPECTION PORT

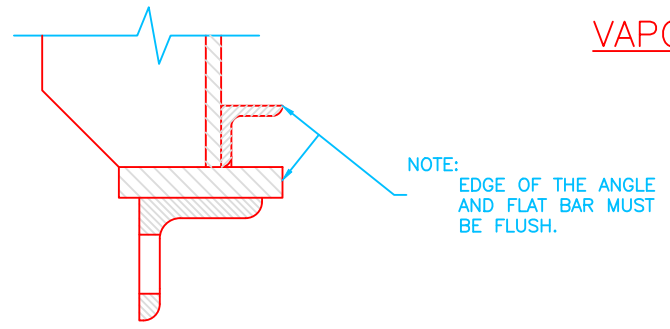

TOLERANCES UNLESS OTHERWISE SPECIFIED		Vincent CORPORATION TAMPA, FLORIDA	
FRACT.	DECIM.	ANGUL.	VP-30 PRESS VAPOR TIGHT RIGHT SIDE COVER ASSEMBLY
± 1/32	± .004	± .5°	
APPROVALS	DATE	SIZE	DRAWING NO.
DRAWN EG	03/23/07	B	94294
CHECKED		THIS PRINT IS THE PROPERTY OF VINCENT CORPORATION AND IS RECALLABLE AT ANY TIME. IT MUST NOT BE COPIED OR USED DETRIMENTALLY TO OUR INTERESTS.	
COMP. NAME 07037_Master			
W. O. NO. 07037	SCALE 2" = 1'-0"	DO NOT SCALE DWG.	SHEET

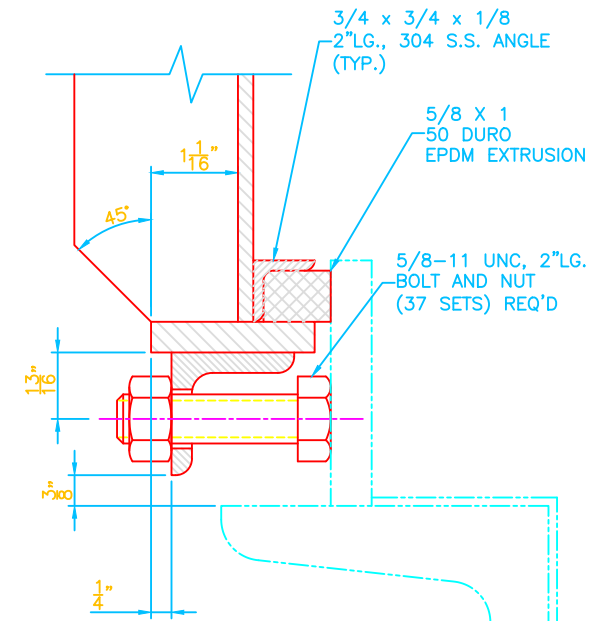
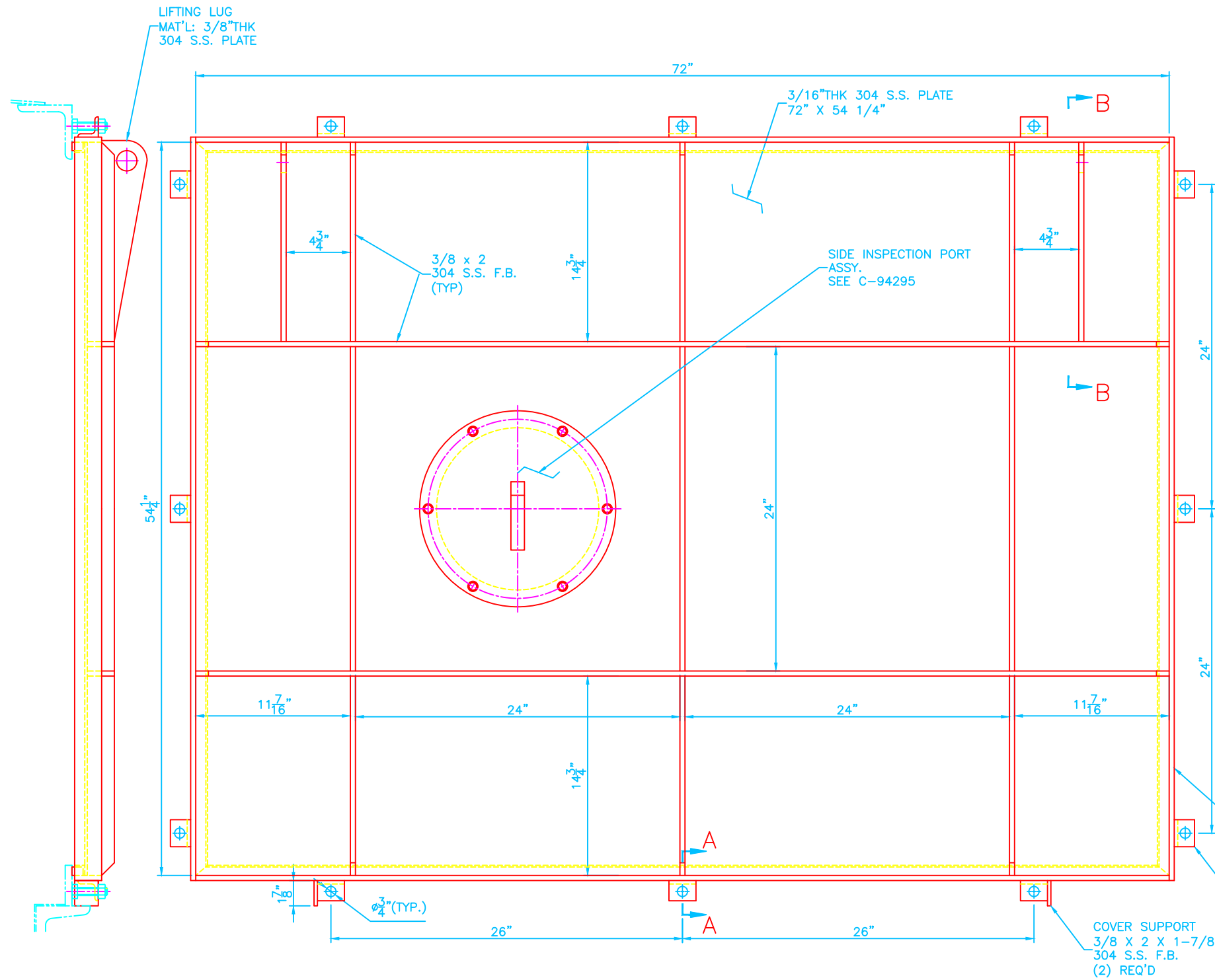

SECTION A-A
N.T.S.

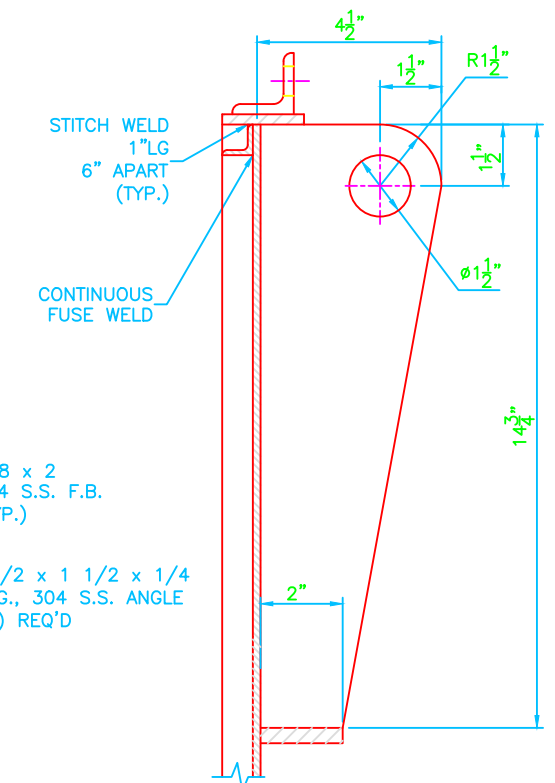

SECTION B-B
N.T.S.

VAPOR TIGHT LEFT SIDE COVER

- (1) REQ'D WITH SIDE INSPECTION PORT
- (1) REQ'D WITHOUT SIDE INSPECTION PORT

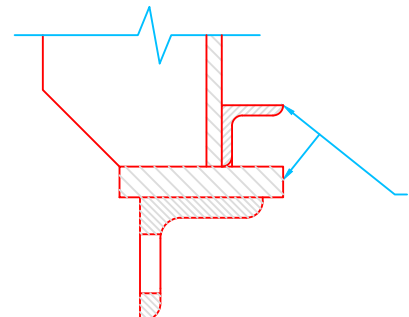

NOTE:
EDGE OF THE ANGLE
AND FLAT BAR MUST
BE FLUSH.

TOLERANCES UNLESS OTHERWISE SPECIFIED	
FRACT.	DECIM. ANGUL.
± 1/32	± .004 ± .5°
APPROVALS	DATE
DRAWN EG	03/23/07
CHECKED	
COMP. NAME 07037_Master	
W. O. NO. 07037	

Vincent CORPORATION TAMPA, FLORIDA	
VP-30 PRESS VAPOR TIGHT LEFT SIDE COVER ASSEMBLY	
THIS PRINT IS THE PROPERTY OF VINCENT CORPORATION AND IS RECALLABLE AT ANY TIME. IT MUST NOT BE COPIED OR USED DETRIMENTALLY TO OUR INTERESTS.	
SIZE B	DRAWING NO. 94294-A
SCALE 2" = 1'-0"	DO NOT SCALE DWG. SHEET

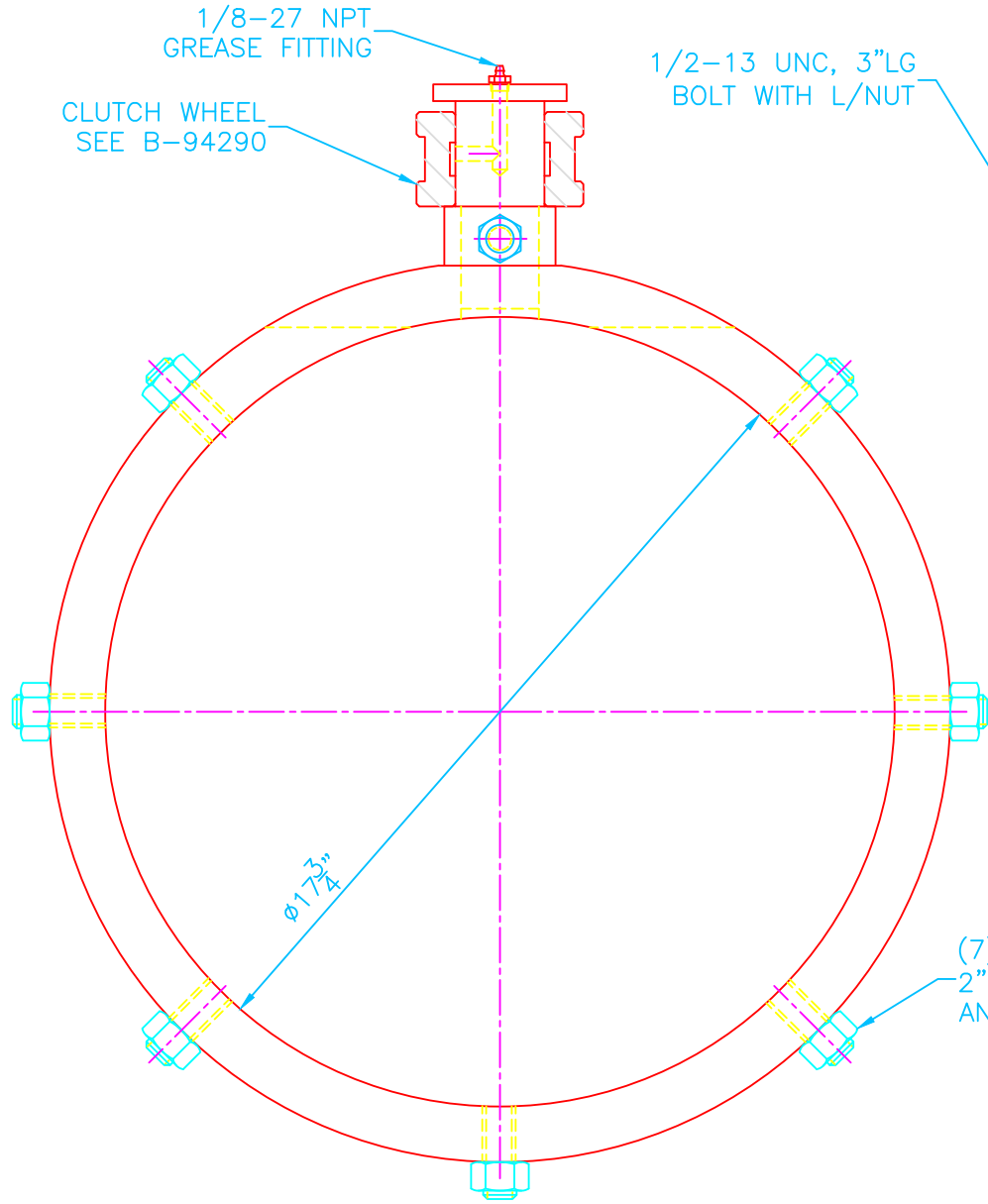

COLLAR CLUTCH ASSEMBLY

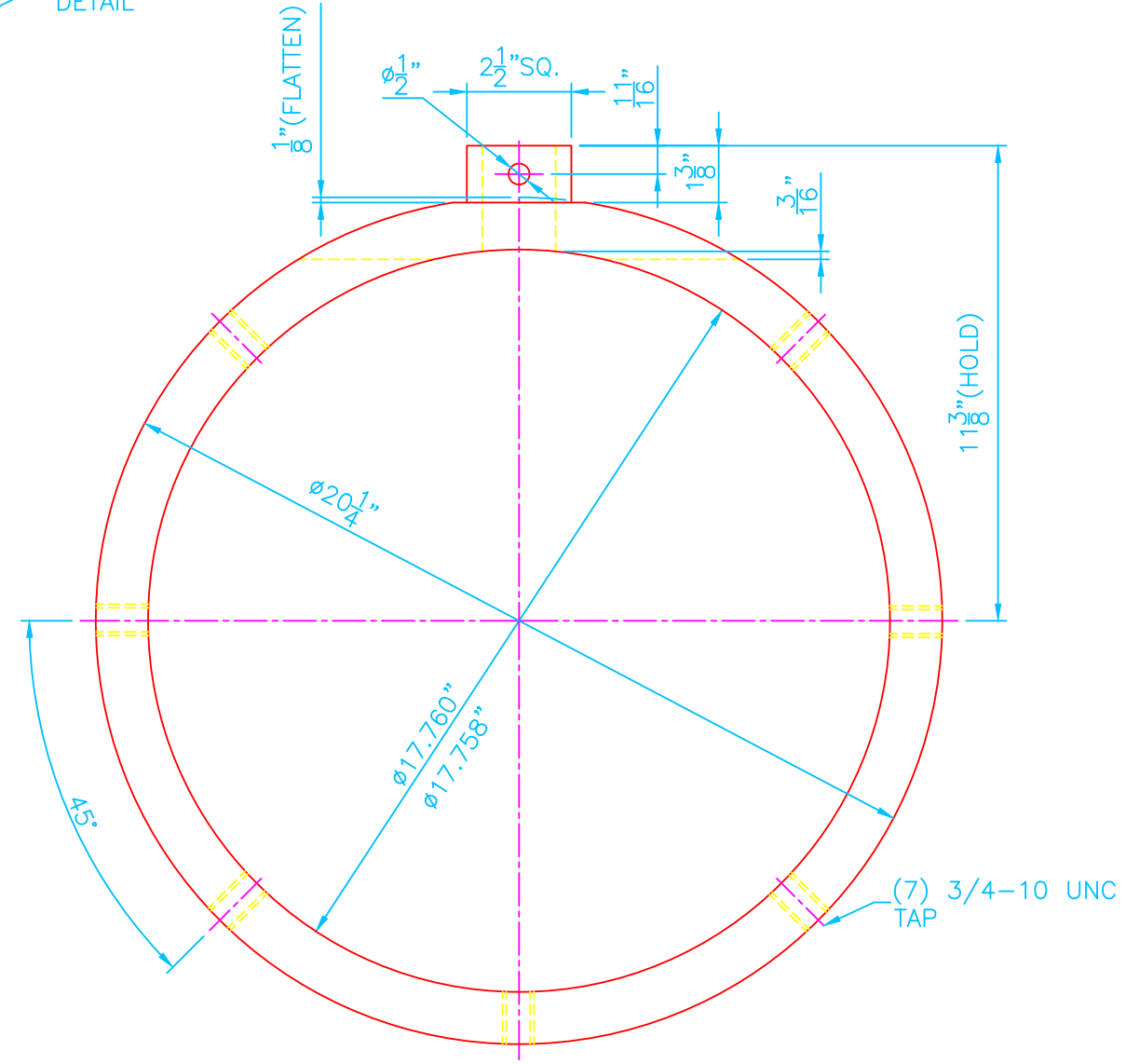
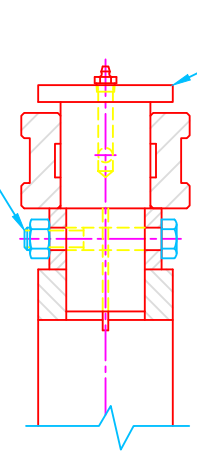

COLLAR CLUTCH

MAT'L: 304 S.S.

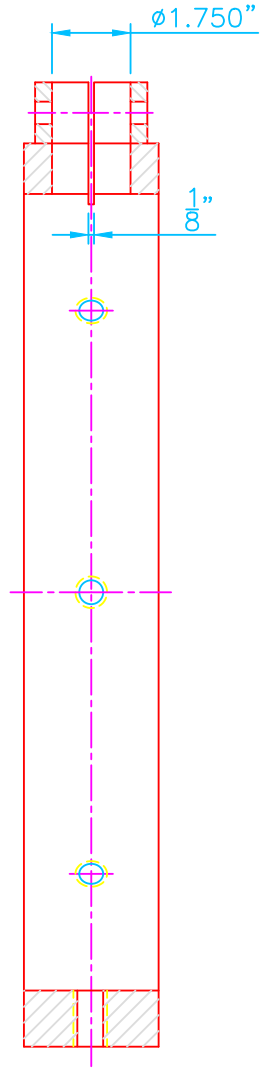

NOTE:
BREAK ALL SHARP EDGES
WITH 1/32" X 45° CHAMFER

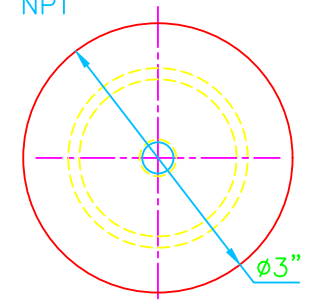
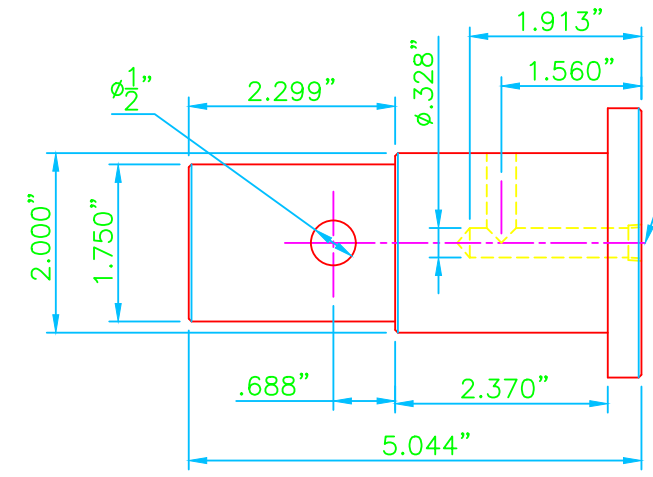

AXLE

N.T.S.
MAT'L: 3" DIA. 304 S.S. ROD
(2) REQ'D

TOLERANCES UNLESS OTHERWISE SPECIFIED		
FRACT.	DECIM.	ANGUL.
± 1/32	± .004	± .5°
APPROVALS	DATE	
DRAWN EG	03/23/07	
CHECKED		
COMP. NAME	07037_Master	
W. O. NO.	07037	

Vincent CORPORATION		TAMPA, FLORIDA	
VP-30 PRESS COLLAR CLUTCH ASSEMBLY			
THIS PRINT IS THE PROPERTY OF VINCENT CORPORATION AND IS RECALLABLE AT ANY TIME. IT MUST NOT BE COPIED OR USED DETRIMENTALLY TO OUR INTERESTS.		SIZE B	DRAWING NO. 94295
SCALE N.T.S.	DO NOT SCALE DWG.	SHEET	

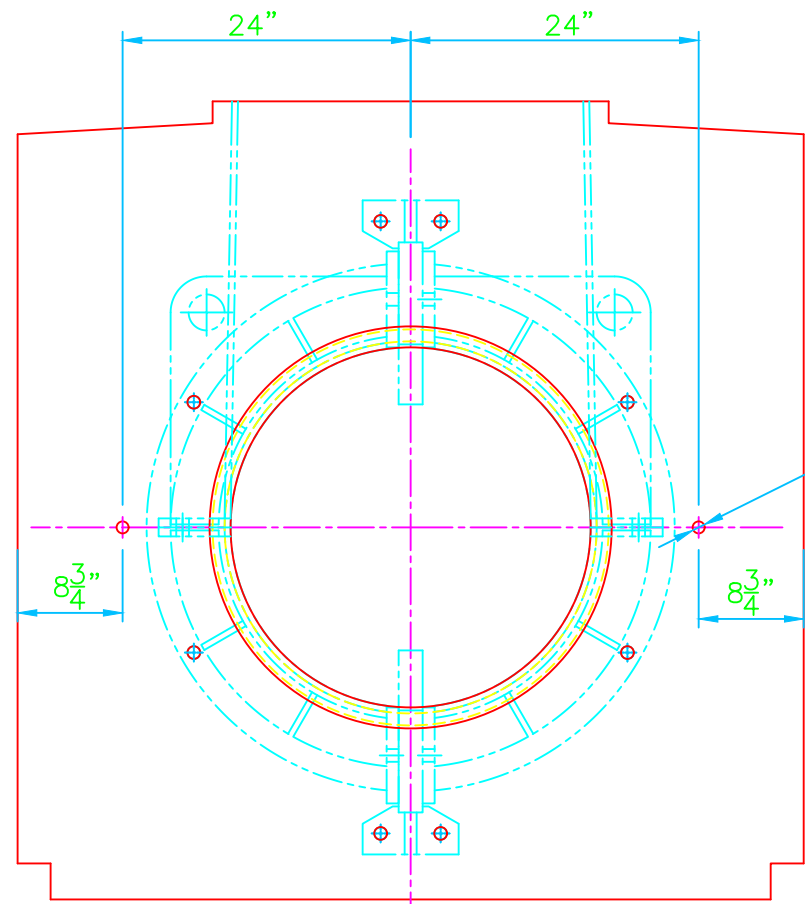

"B" PLATE

(2) $\phi 1$ " DRILL

(2) $\phi 1$ " DRILL

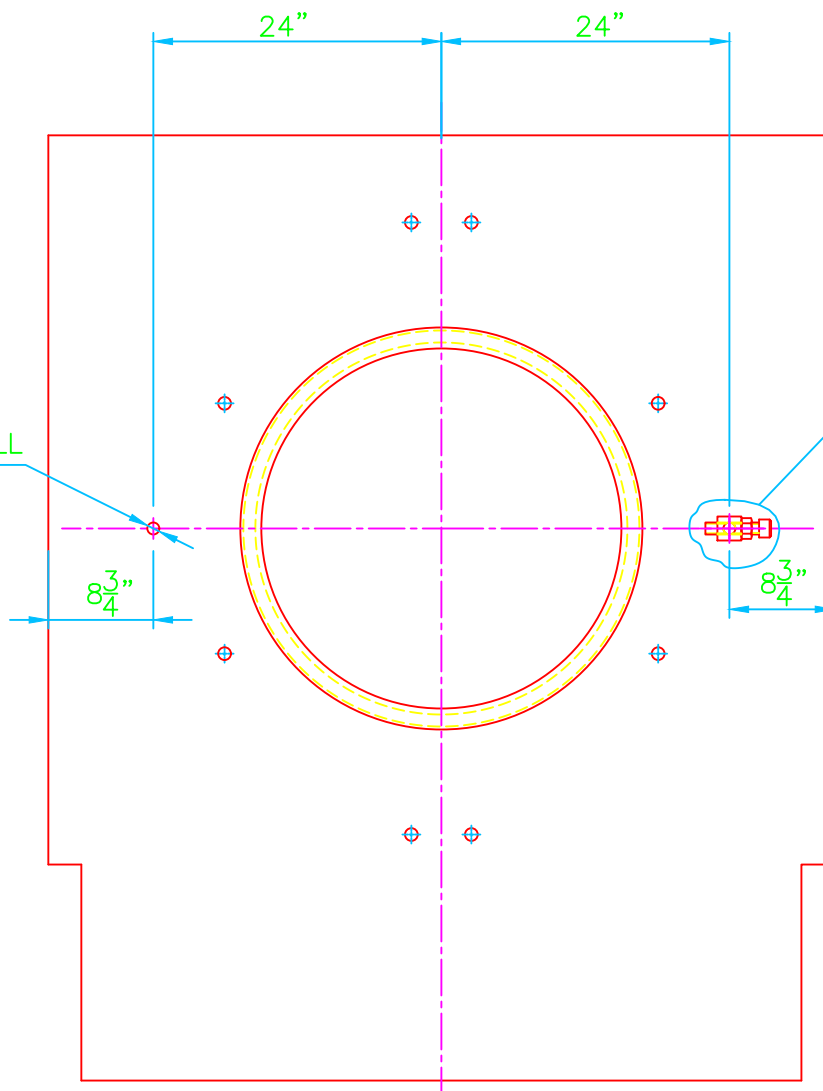

"C" PLATE

1-14 UNF, 4-1/2" LG
SOCKET HEAD BOLT
WITH JAM NUT
(4 SETS) REQ'D FOR
EACH PRESS

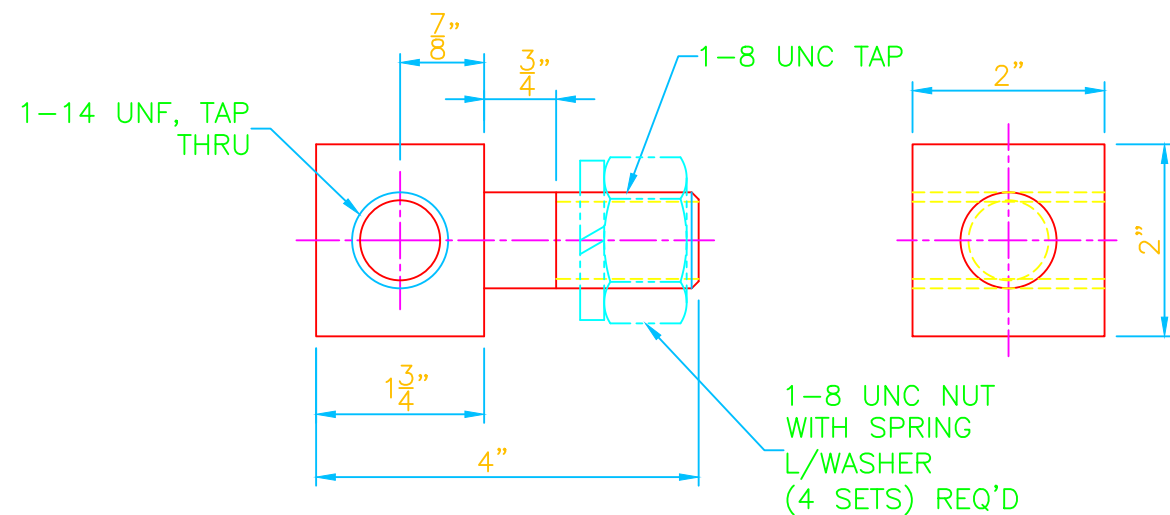
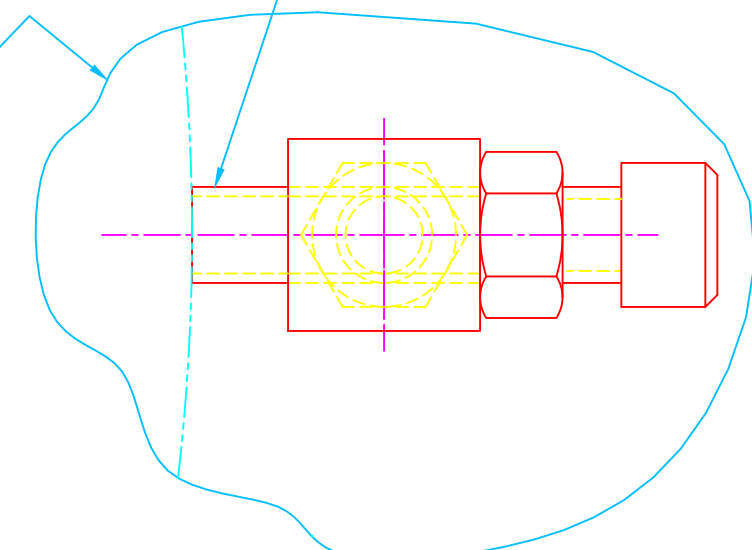

REMOVABLE JACK BLOCK

N.T.S.
2" SQ. B. 304 S.S.
(4) REQ'D FOR EACH PRESS

TOLERANCES UNLESS OTHERWISE SPECIFIED		Vincent CORPORATION TAMPA, FLORIDA	
FRACT.	DECIM.	ANGUL.	VP-30 PRESS
$\pm 1/32$	$\pm .004$	$\pm .5^\circ$	"B" & "C" PLATES MODIFICATION AND REMOVABLE JACK BLOCK
APPROVALS	DATE	SIZE	DRAWING NO.
DRAWN EG	11/19/07	B	94295-A
CHECKED		THIS PRINT IS THE PROPERTY OF VINCENT CORPORATION AND IS RECALLABLE AT ANY TIME. IT MUST NOT BE COPIED OR USED DETRIMENTALLY TO OUR INTERESTS.	
COMP. NAME	07037_Master	SCALE	N.T.S. DO NOT SCALE DWG.
W. O. NO.	07037		SHEET

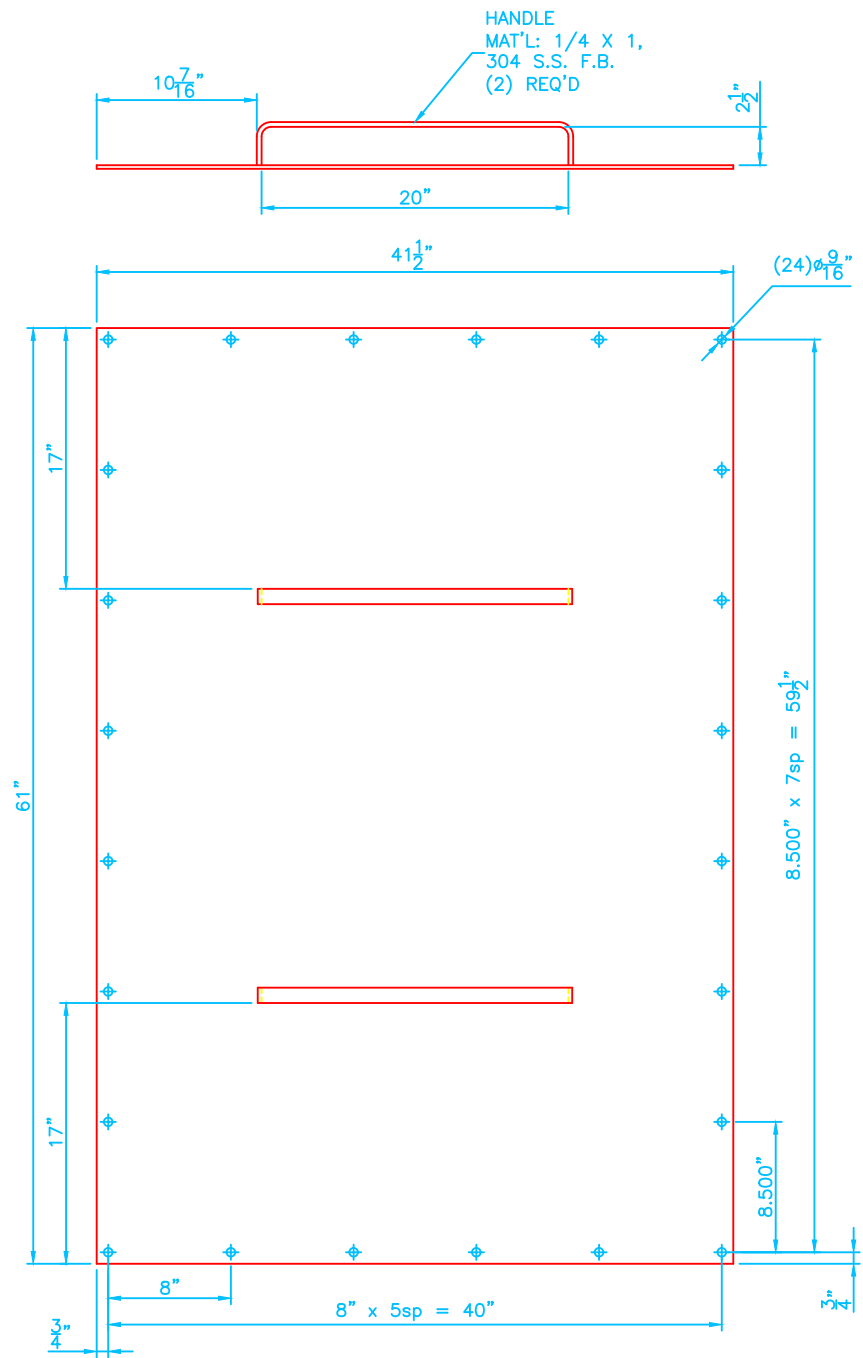

DISCHARGE TOP COVER

MAT'L: 3/16"THK. 304 S.S. PLATE

1/2-13 UNC, 1"LG
STUD WITH NUT
(100 SETS) REQ'D

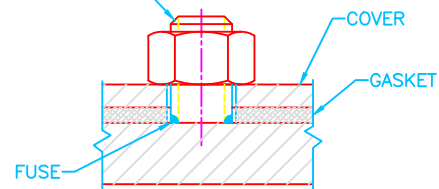

COVER ATTACHMENT DETAILS

(TYP.)

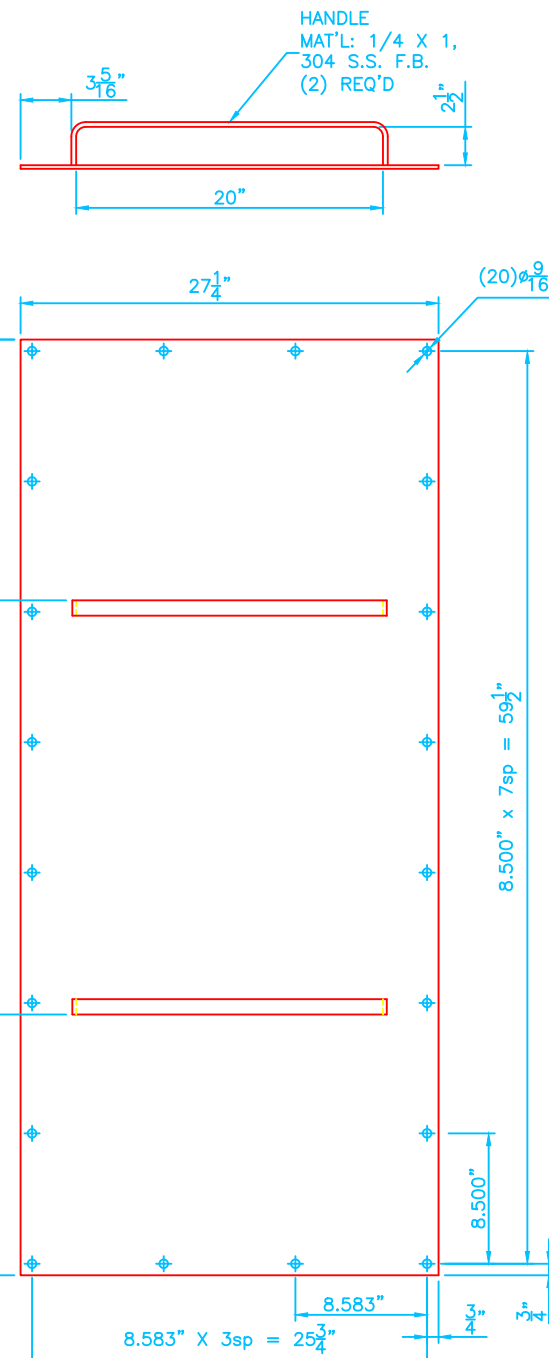

SCREEN TOP COVER

MAT'L: 3/16"THK. 304 S.S. PLATE
(2) REQ'D

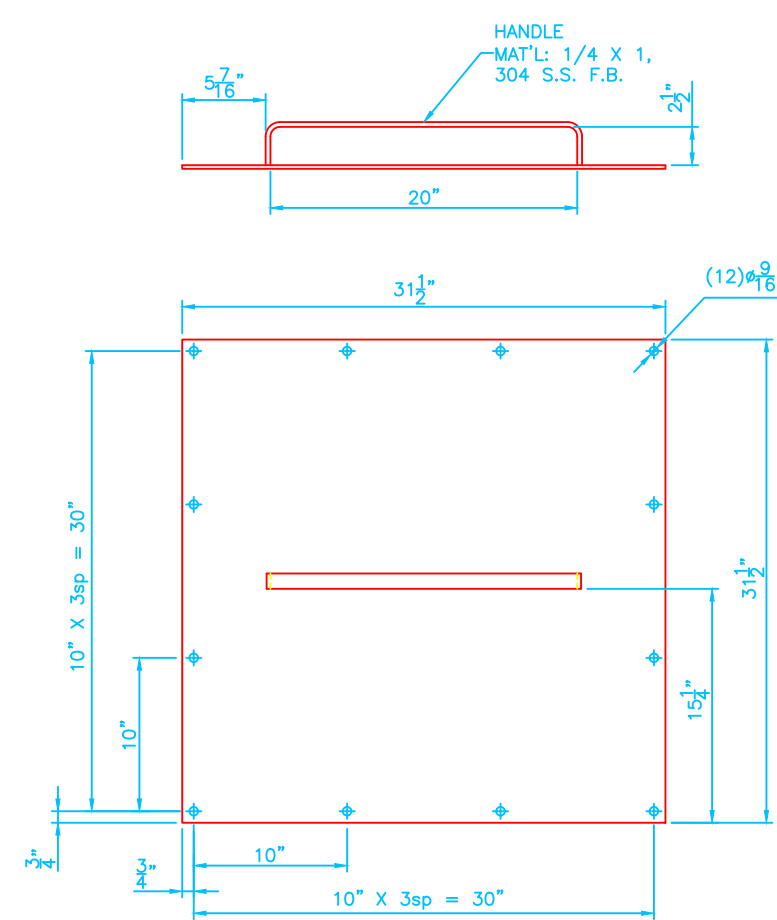

DISCHARGE SIDE COVER

MAT'L: 3/16"THK. 304 S.S. PLATE
(2) REQ'D

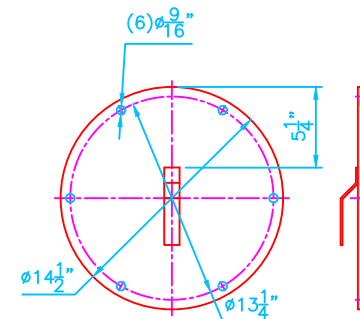

INSPECTION PORT COVER

MAT'L: 3/16"THK. 304 S.S. PLATE
(2) REQ'D

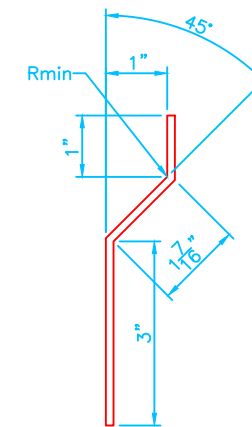

HANDLE

N.T.S.
MAT'L: 1/8 X 1, 304 S.S. F.B.
(5) REQ'D

TOLERANCES UNLESS OTHERWISE SPECIFIED			Vincent CORPORATION TAMPA, FLORIDA	
FRACT.	DECIM.	ANGUL.	VP-30 PRESS SET OF COVERS FOR ONE UNIT	
± 1/32	± .004	± 5°	SALE FAC	
APPROVALS	DATE	THIS PRINT IS THE PROPERTY OF VINCENT CORPORATION AND IS RECALLABLE AT ANY TIME. IT MUST NOT BE COPIED OR USED DETRIMENTALLY TO OUR INTERESTS.		
DRAWN EG	03/23/07	SIZE C	DRAWING NO. 94296	
CHECKED		W. O. NO. 07037 Master		
SCALE 1 1/2" = 1'-0"		DO NOT SCALE DWG.		SHEET

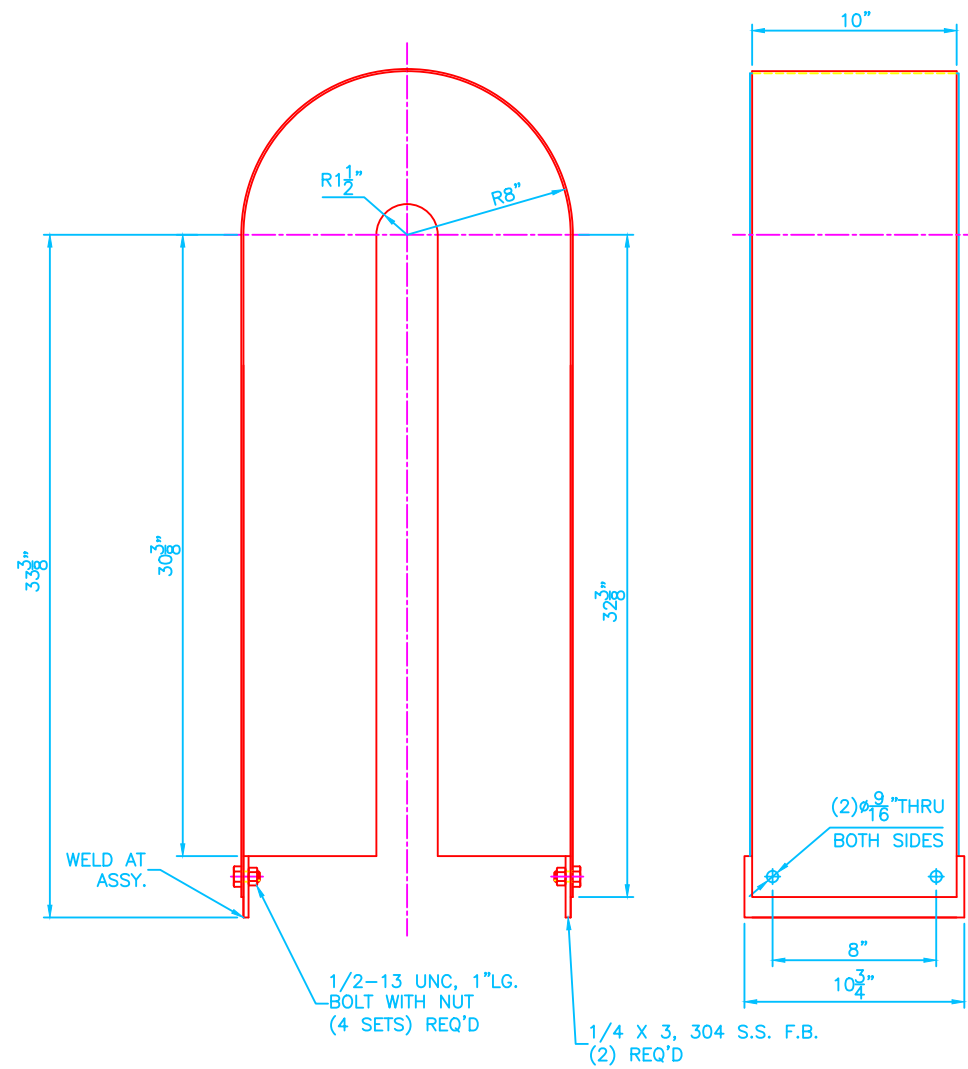

MOTOR COUPLING COVER
 MAT'L: 16GA. 201 S.S. SHEET

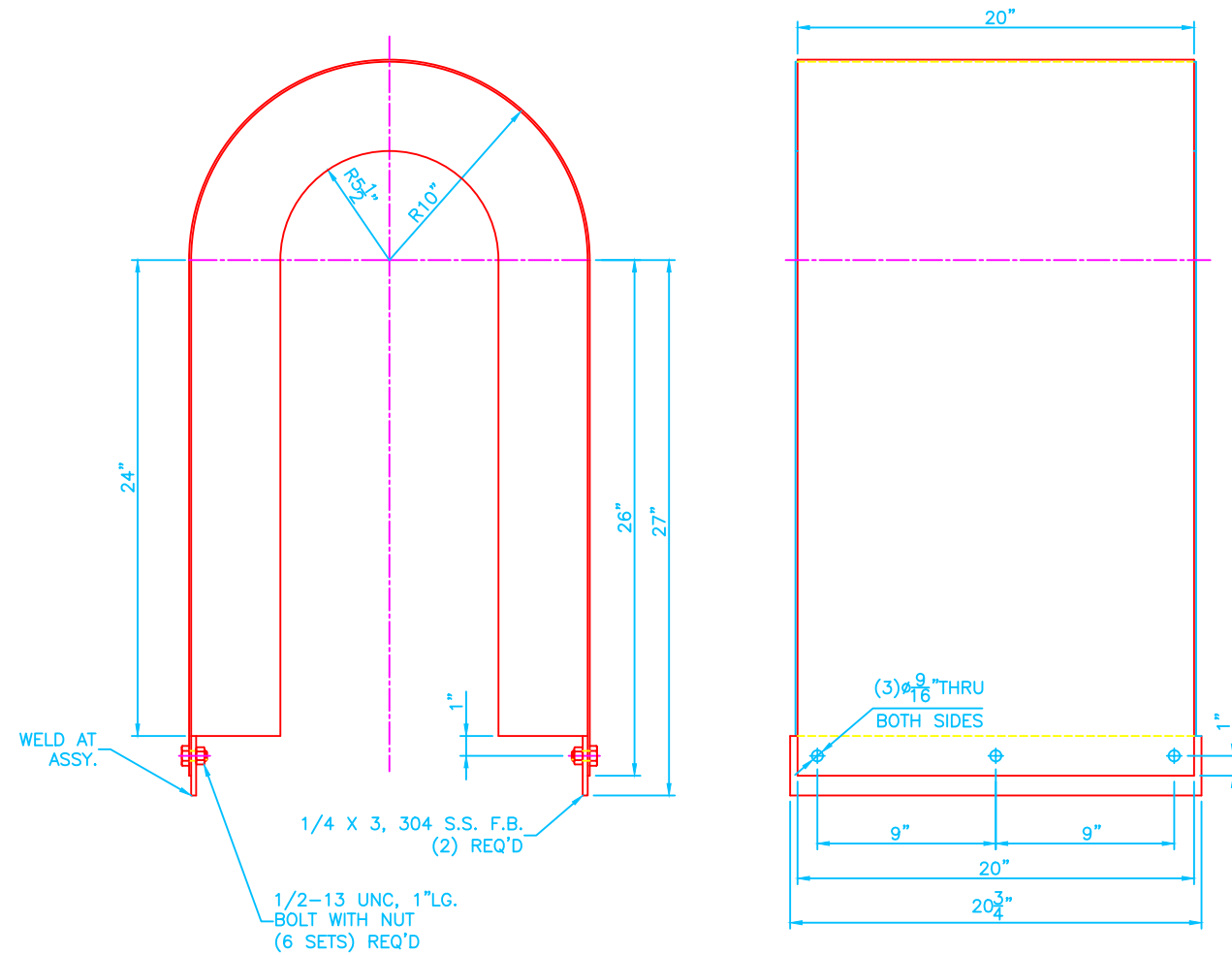

REDUCER COUPLING COVER
 MAT'L: 16GA. 201 S.S. SHEET

TOLERANCES UNLESS OTHERWISE SPECIFIED			Vincent CORPORATION TAMPA, FLORIDA	
FRACT.	DECIM.	ANGUL.		
± 1/32	± .004	± .5°	APPROVALS	DATE
			DRAWN EG	03/23/07
THIS PRINT IS THE PROPERTY OF VINCENT CORPORATION AND IS RECALLABLE AT ANY TIME. IT MUST NOT BE COPIED OR USED DETRIMENTALLY TO OUR INTERESTS.			SIZE C	DRAWING NO. 94297
COMP. NAME 07037_Master	SCALE 2" = 1'-0"		DO NOT SCALE DWG.	SHEET
W. O. NO. 07037				

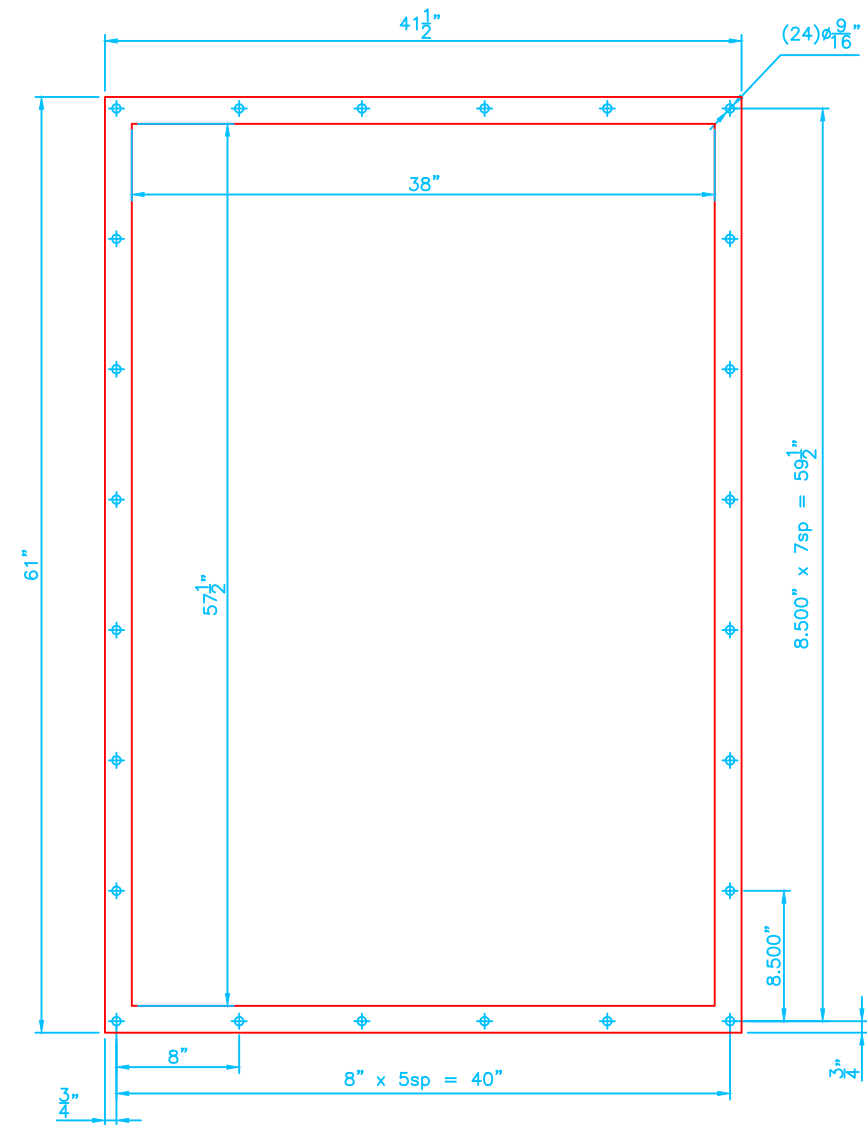

DISCHARGE TOP GASKET
(1) REQ'D

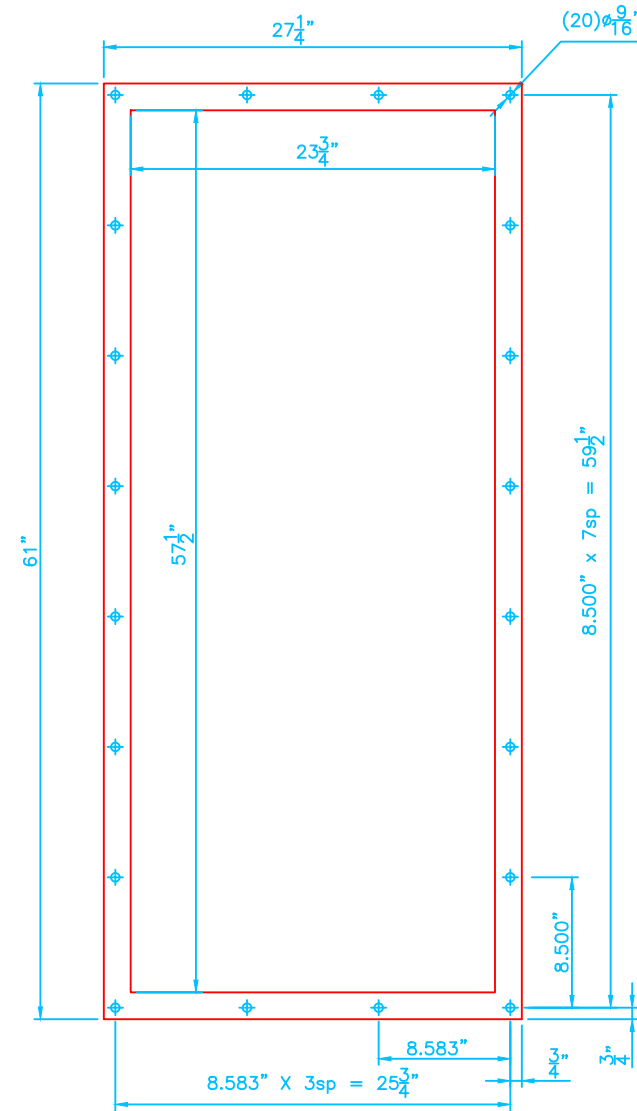

SCREEN TOP GASKET
(2) REQ'D

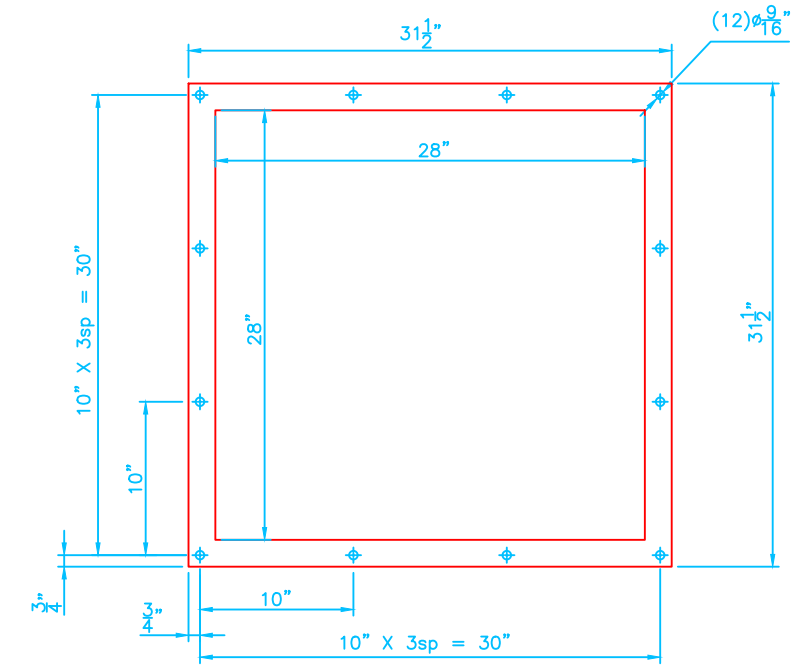

DISCHARGE SIDE GASKET
(2) REQ'D

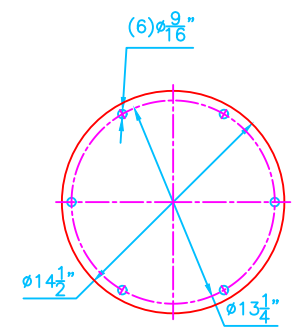

INSPECTION PORT GASKET
(2) REQ'D

MAT'L TO BE 1/8" THK.
VEG FIBER

TOLERANCES UNLESS OTHERWISE SPECIFIED			Vincent CORPORATION TAMPA, FLORIDA	
FRACT.	DECIM.	ANGUL.	VP-30 PRESS	
± 1/32	± .004	± .5°	SET OF GASKETS FOR ONE UNIT	
APPROVALS	DATE	DRAWING NO.		
DRAWN	06/23/07	C 94298		
CHECKED	THIS PRINT IS THE PROPERTY OF VINCENT CORPORATION AND IS RECALLABLE AT ANY TIME. IT MUST NOT BE COPIED OR USED DETRIMENTALLY TO OUR INTERESTS.			SIZE
COMP. NAME	07037_Master	C		
W. O. NO.	07037	SCALE	1 1/2" = 1'-0"	DO NOT SCALE DWG. SHEET

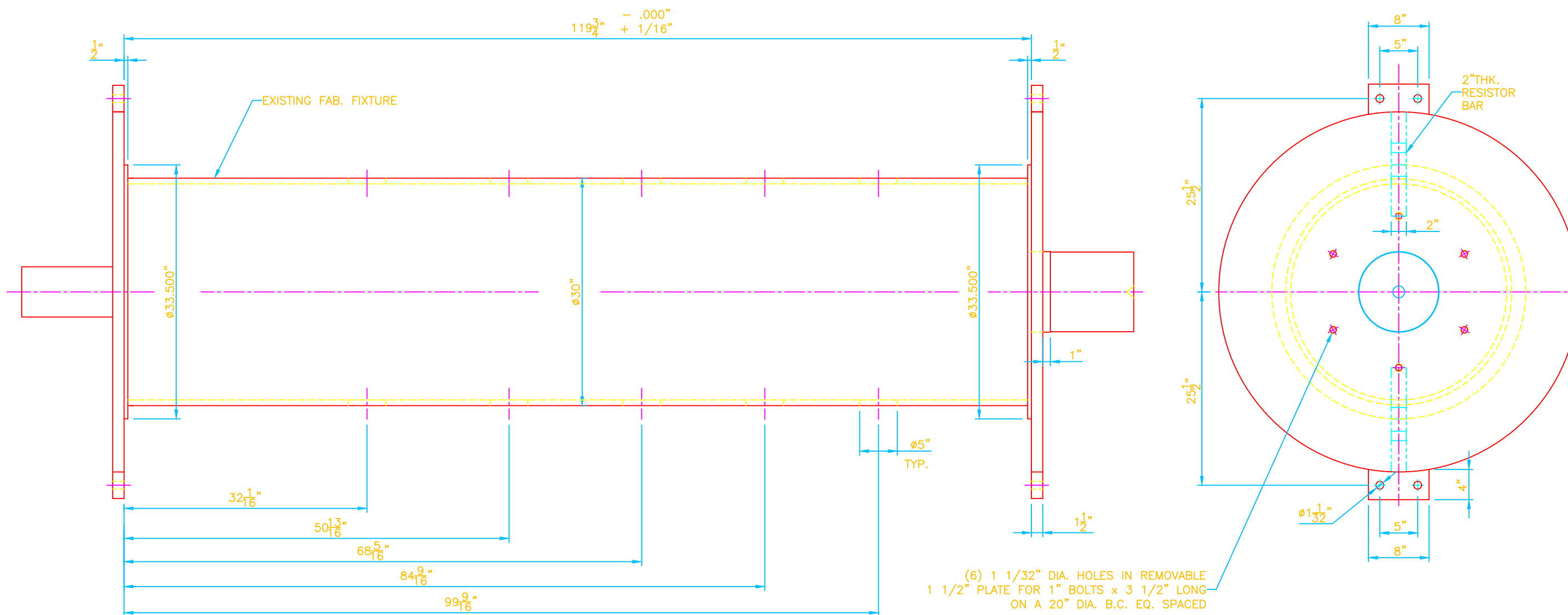

TOLERANCES UNLESS OTHERWISE SPECIFIED

FRACT.	DECIM.	ANGUL.
$\pm 1/32$	$\pm .004$	$\pm .5^\circ$

Vincent CORPORATION
TAMPA, FLORIDA

VP-30 PRESS
SCREE FRAME FABRICATING
FIXTURE

APPROVALS	DATE
DRAWN EG	04/03/07

CHECKED	
---------	--

COMP. NAME 07037_Master

W. O. NO. 07037

THIS PRINT IS THE PROPERTY OF VINCENT CORPORATION AND IS RECALLABLE AT ANY TIME. IT MUST NOT BE COPIED OR USED DETRIMENTALLY TO OUR INTERESTS.

SIZE	DRAWING NO.
B	

SCALE 1" = 1'-0" DO NOT SCALE DWG. SHEET

BOTTOM FLANGE
ONLY FOR ANCHOR
BOLTS

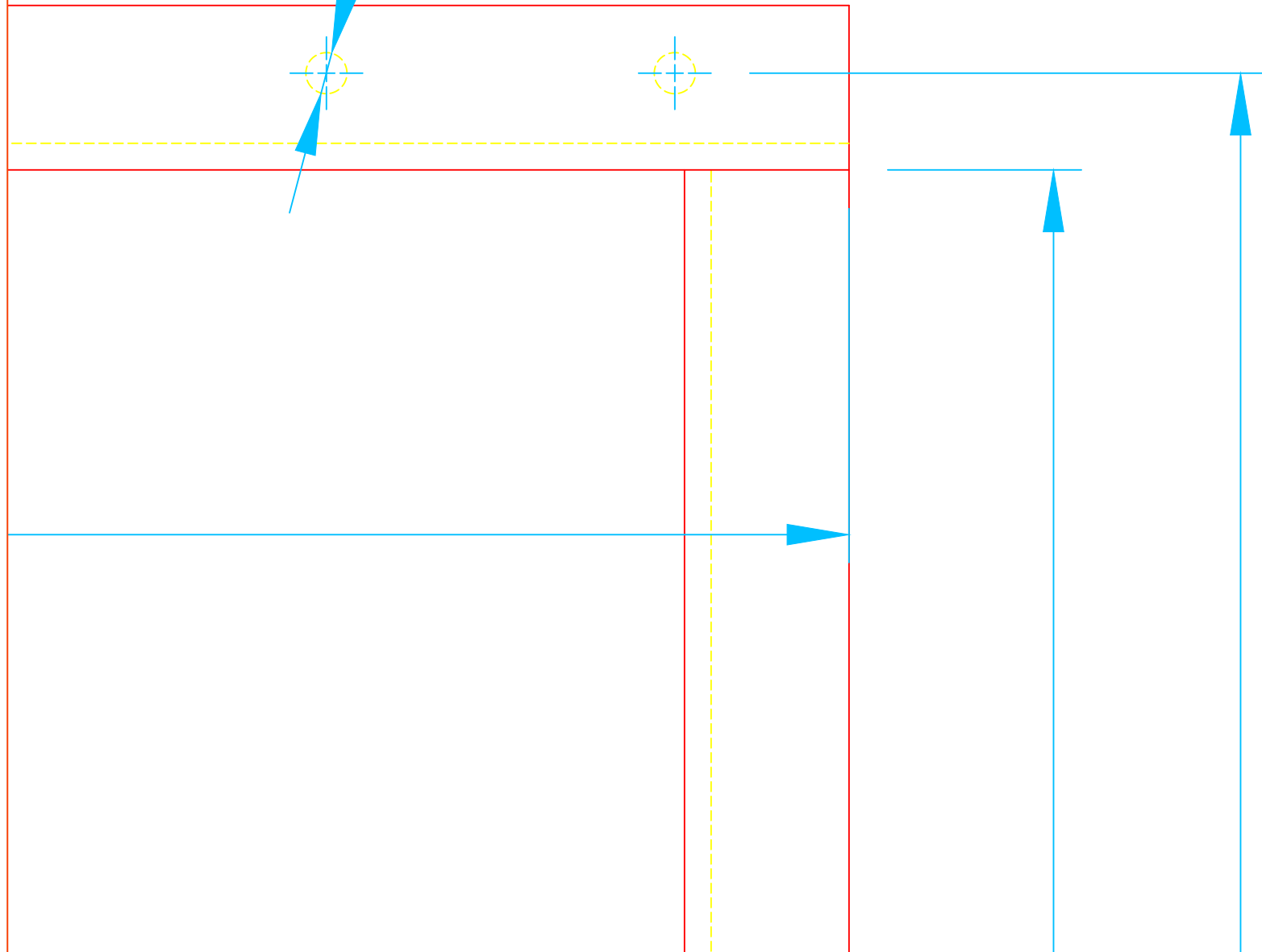

TOLERANCES UNLESS OTHERWISE SPECIFIED			Vincent CORPORATION TAMPA, FLORIDA	
FRACT.	DECIM.	ANGUL.		
± 1/32	± .004	± .5°	VP-30 PRESS PRESS SUPPORT RIGHT SIDE	
APPROVALS	DATE			
DRAWN	EG	04/03/07	THIS PRINT IS THE PROPERTY OF VINCENT CORPORATION AND IS RECALLABLE AT ANY TIME. IT MUST NOT BE COPIED OR USED DETRIMENTALLY TO OUR INTERESTS.	
CHECKED				
COMP. NAME	07037_Master		SIZE	DRAWING NO.
W. O. NO.	07037		B	94298-A
SCALE 3" = 1'-0"			DO NOT SCALE DWG.	SHEET

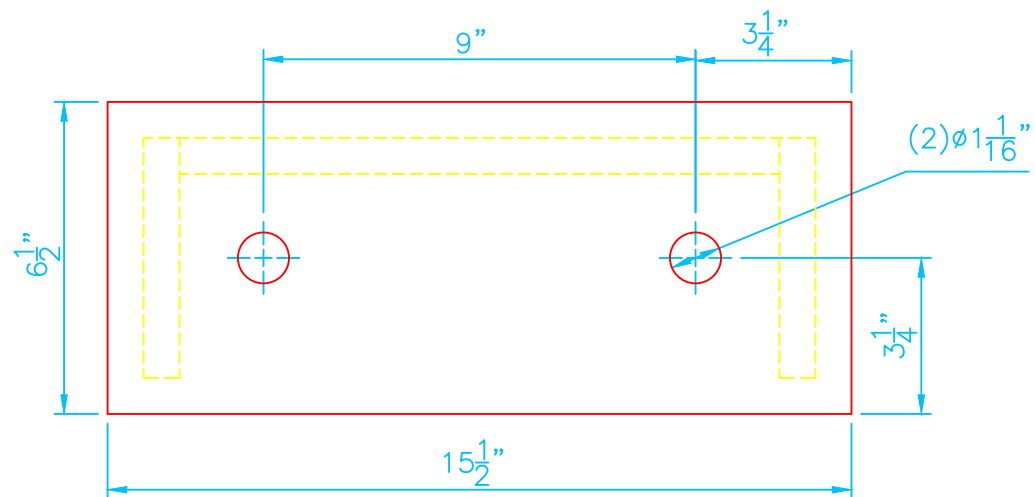
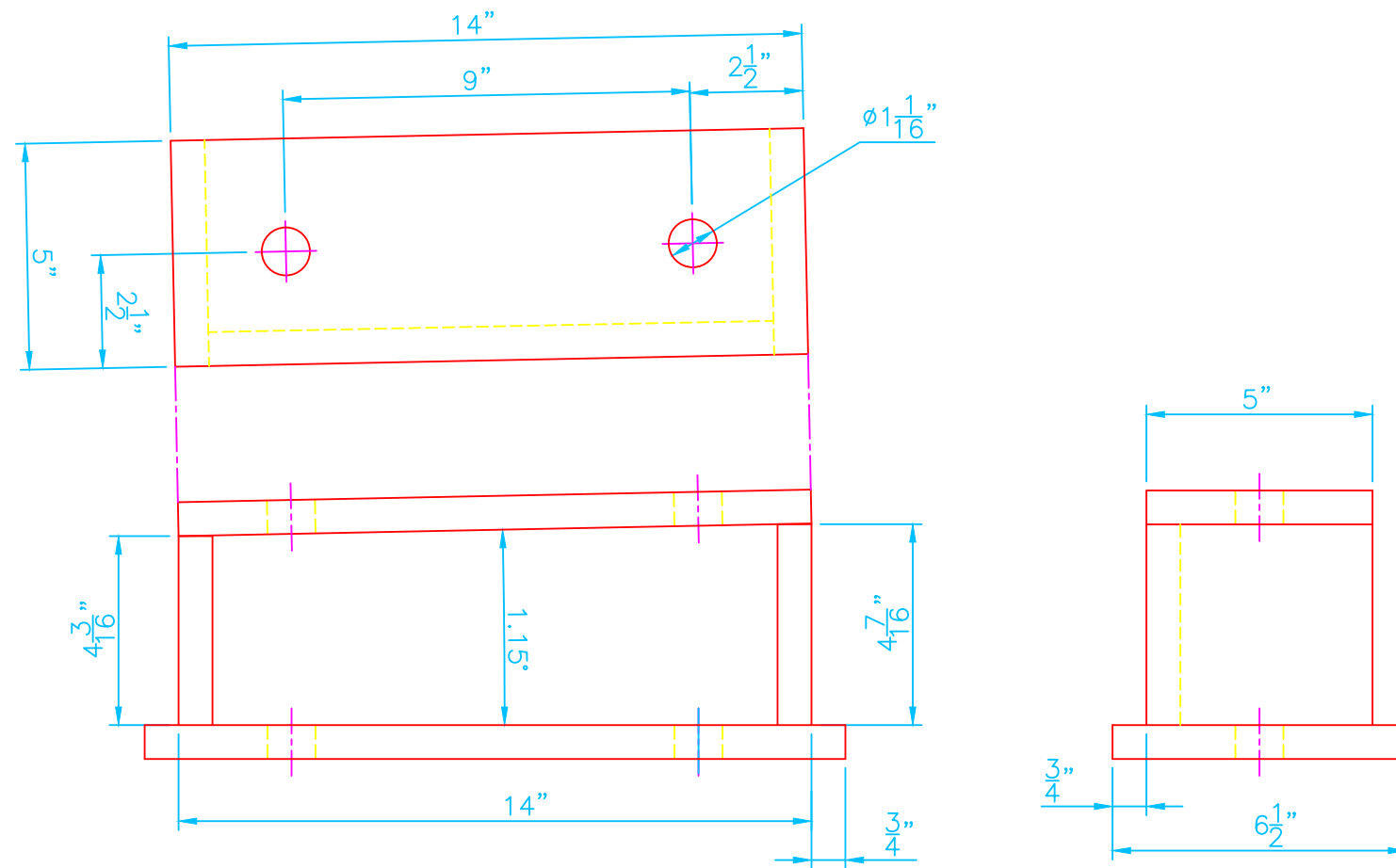

PRESS SUPPORT (LEFT SIDE)

MAT'L: 3/4"THK. M.S. PLATE

TOLERANCES UNLESS OTHERWISE SPECIFIED			Vincent CORPORATION TAMPA, FLORIDA		
FRACT.	DECIM.	ANGUL.			
± 1/32	± .004	± .5°	VP-30 PRESS PRESS SUPPORT LEFT SIDE		
APPROVALS	DATE				
DRAWN	EG	04/03/07		THIS PRINT IS THE PROPERTY OF VINCENT CORPORATION AND IS RECALLABLE AT ANY TIME. IT MUST NOT BE COPIED OR USED DETRIMENTALLY TO OUR INTERESTS.	
CHECKED			SIZE B		DRAWING NO. 94298-B
COMP. NAME 07037_Master					
W. O. NO. 07037			SCALE 3" = 1'-0"	DO NOT SCALE DWG.	SHEET

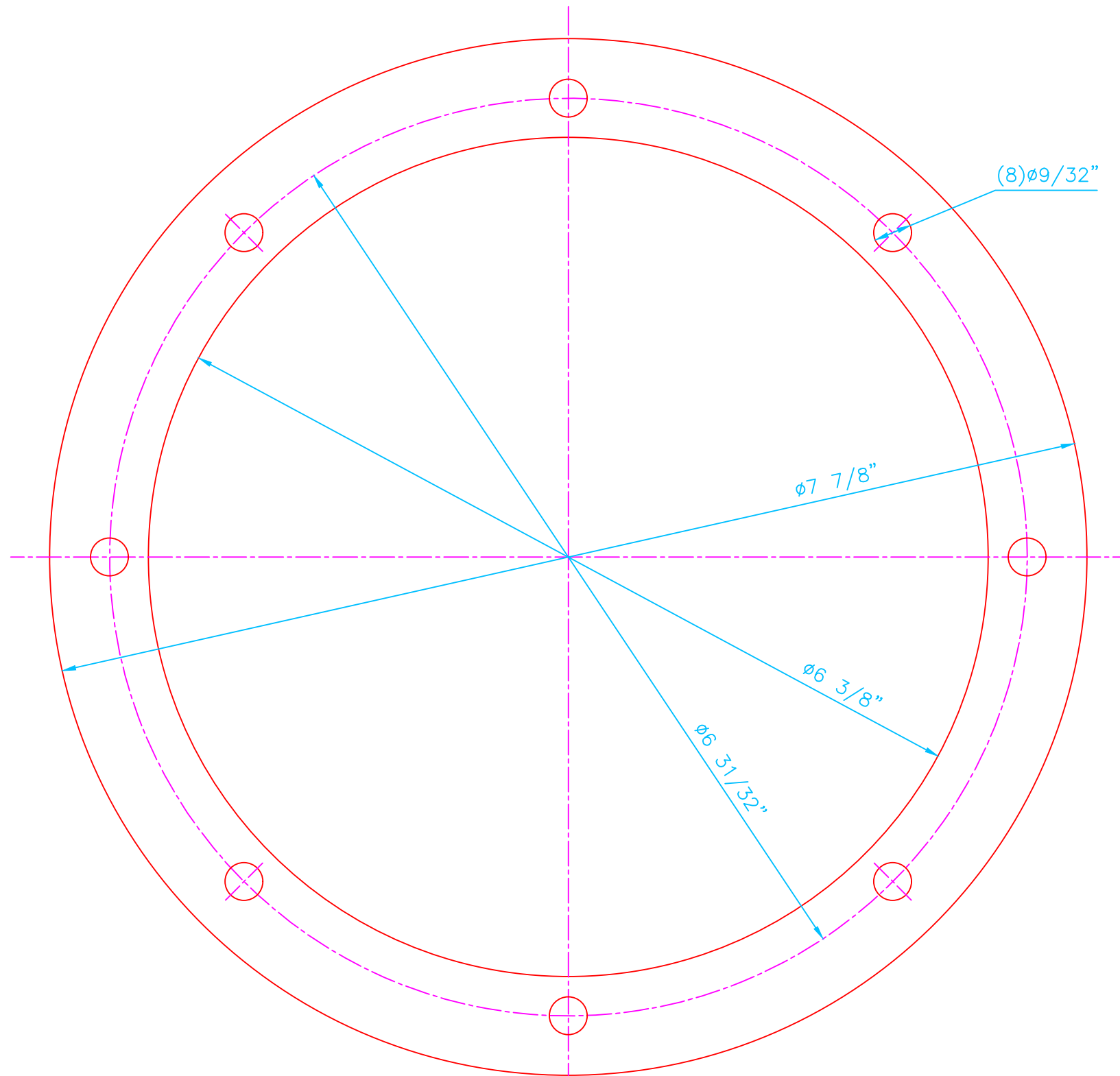

FLANGE

MAT'L: 1/8"THK. 304 S.S. PLATE
(12) REQ'D

TOLERANCES UNLESS OTHERWISE SPECIFIED		Vincent CORPORATION TAMPA, FLORIDA		
FRACT.	DECIM.			ANGUL.
$\pm 1/32$	$\pm .004$	$\pm .5^\circ$		
APPROVALS	DATE	VP-30 PRESS PROTECTO BOOT FLANGE		
DRAWN EG	04/03/07			
CHECKED		THIS PRINT IS THE PROPERTY OF VINCENT CORPORATION AND IS RECALLABLE AT ANY TIME. IT MUST NOT BE COPIED OR USED DETRIMENTALLY TO OUR INTERESTS.	SIZE	DRAWING NO.
COMP. NAME	07037_Master		B	94298-F
W. O. NO.	07037	SCALE FULL	DO NOT SCALE DWG.	SHEET

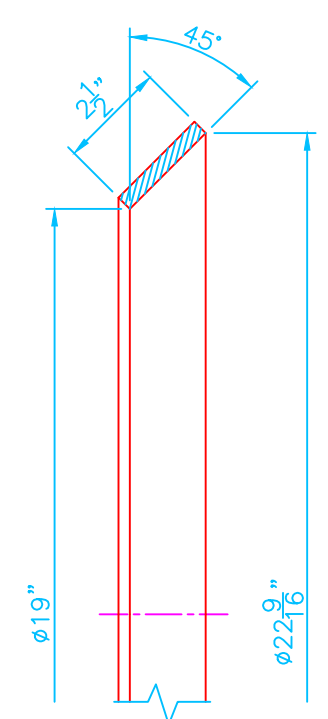
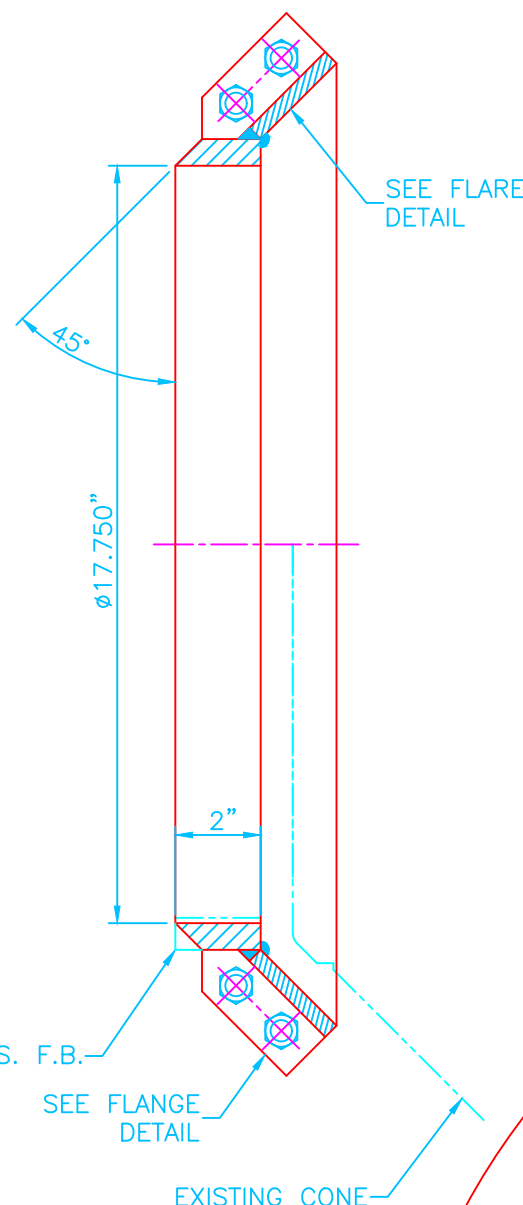
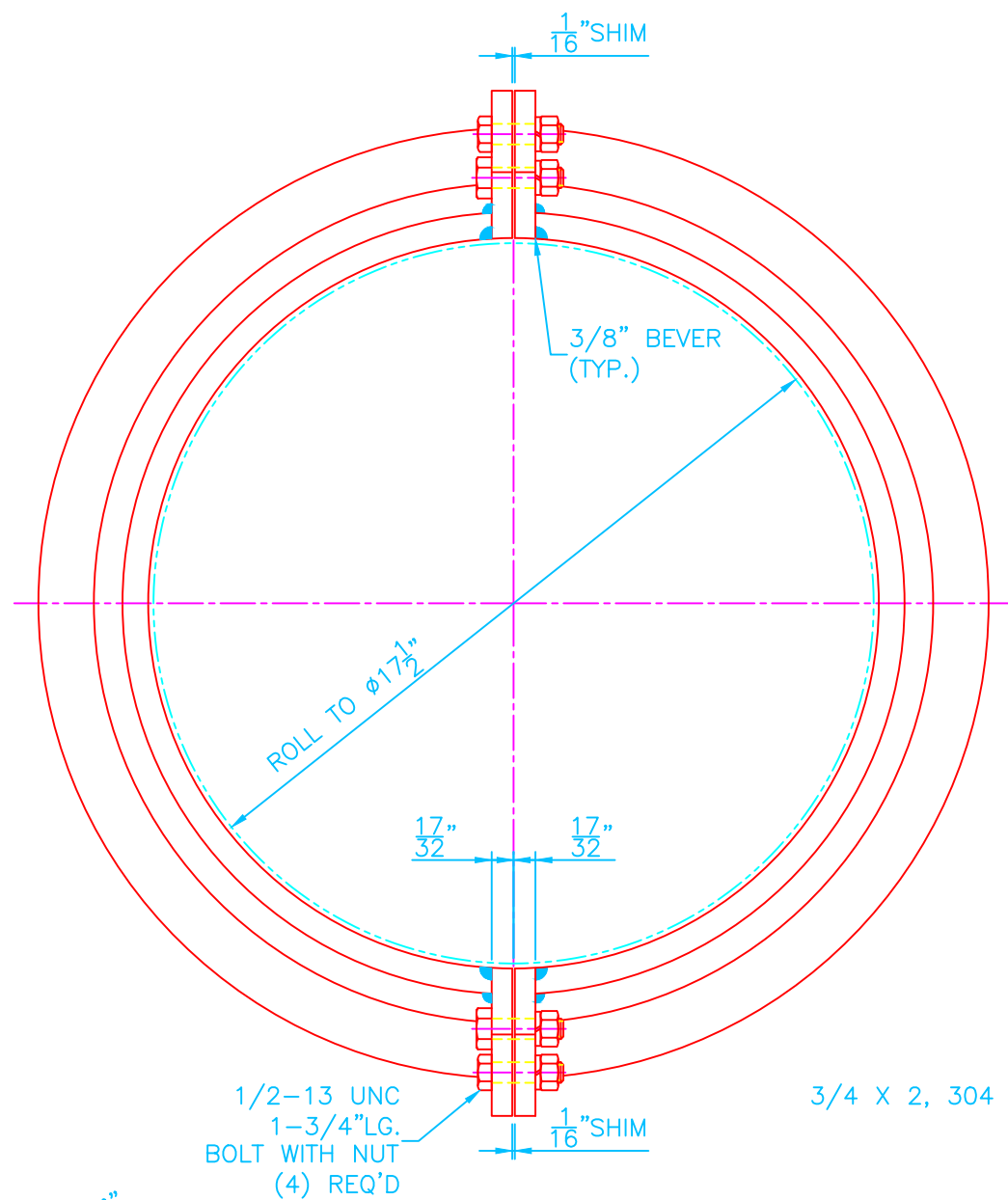

FLARE

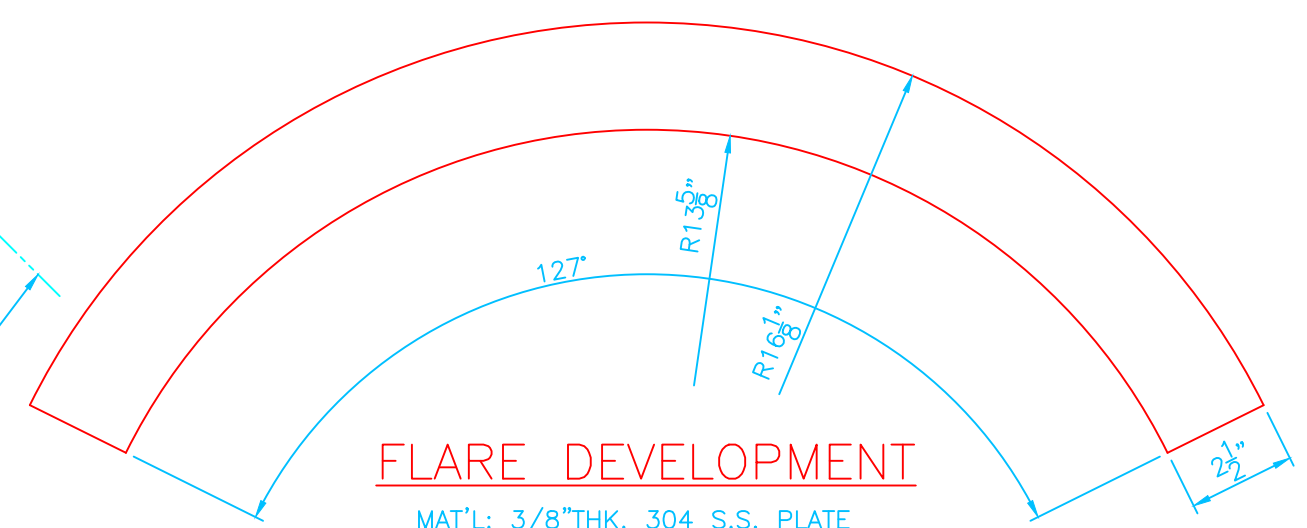

FLARE DEVELOPMENT

MAT'L: 3/8"THK. 304 S.S. PLATE
(2) REQ'D

1/2-13 UNC
1-3/4"LG.
BOLT WITH NUT
(4) REQ'D

3/4 X 2, 304 S.S. F.B.

SHAFT DAM ASSEMBLY

ALL MACHINING MUST BE PROVIDED AFTER FAB. COMPLETE

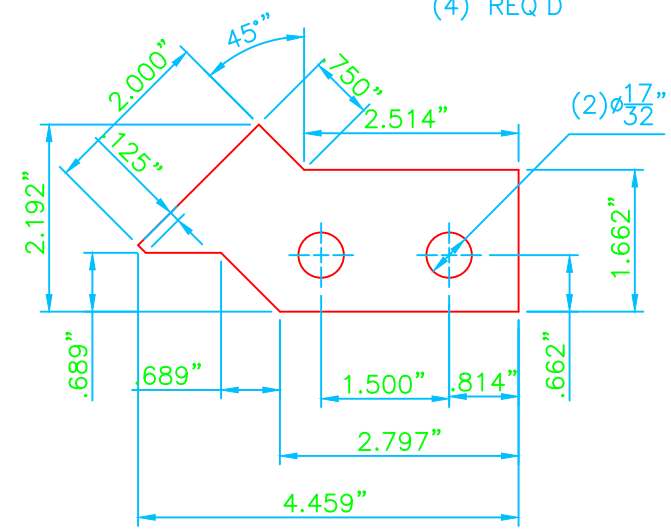

FLANGE

MAT'L: 1/2"THK. 304 S.S. PLATE
(4) REQ'D

TOLERANCES UNLESS OTHERWISE SPECIFIED		
FRACT.	DECIM.	ANGUL.
± 1/32	± .004	± .5°
APPROVALS	DATE	
DRAWN EG	05/19/10	
CHECKED		
COMP. NAME	07037_Master	
W. O. NO.	07037	

Vincent CORPORATION
TAMPA, FLORIDA

VP-30 PRESS
SHAFT DAM
ASSEMBLY

THIS PRINT IS THE PROPERTY OF VINCENT CORPORATION AND IS RECALLABLE AT ANY TIME. IT MUST NOT BE COPIED OR USED DETRIMENTALLY TO OUR INTERESTS.	SIZE B	DRAWING NO. 94298-G
SCALE N.T.S.	DO NOT SCALE DWG.	SHEET

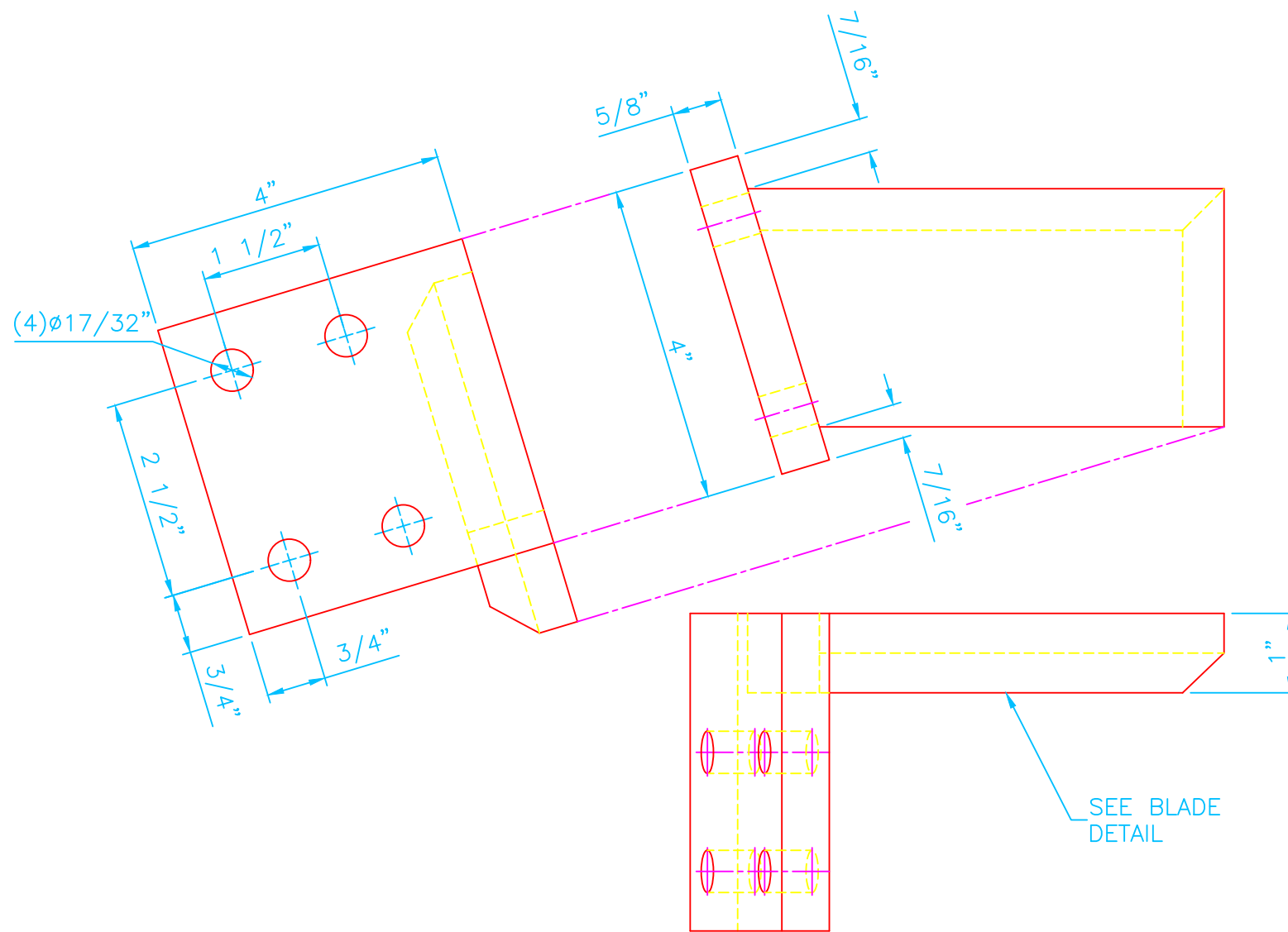

WING FEEDER

MAT'L: 304 S.S. PLATE
(2) REQ'D

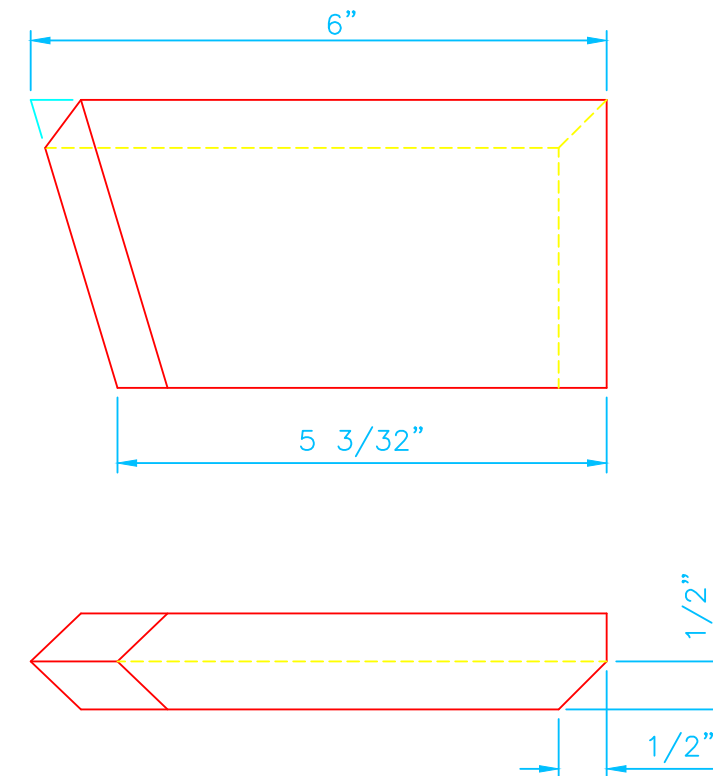

BLADE

MAT'L: 1 X 3, 304 S.S. F.B.

TOLERANCES UNLESS OTHERWISE SPECIFIED			Vincent CORPORATION TAMPA, FLORIDA		
FRACT.	DECIM.	ANGUL.			
± 1/32	± .004	± .5°	VP-30 PRESS WING FEEDER DETAILS		
APPROVALS	DATE				
DRAWN	EG	05/19/10	THIS PRINT IS THE PROPERTY OF VINCENT CORPORATION AND IS RECALLABLE AT ANY TIME. IT MUST NOT BE COPIED OR USED DETRIMENTALLY TO OUR INTERESTS.		
CHECKED					
COMP. NAME	07037_Master		SIZE	DRAWING NO.	
W. O. NO.	07037		B	94298-H	
SCALE N. T. S.			DO NOT SCALE DWG.		SHEET

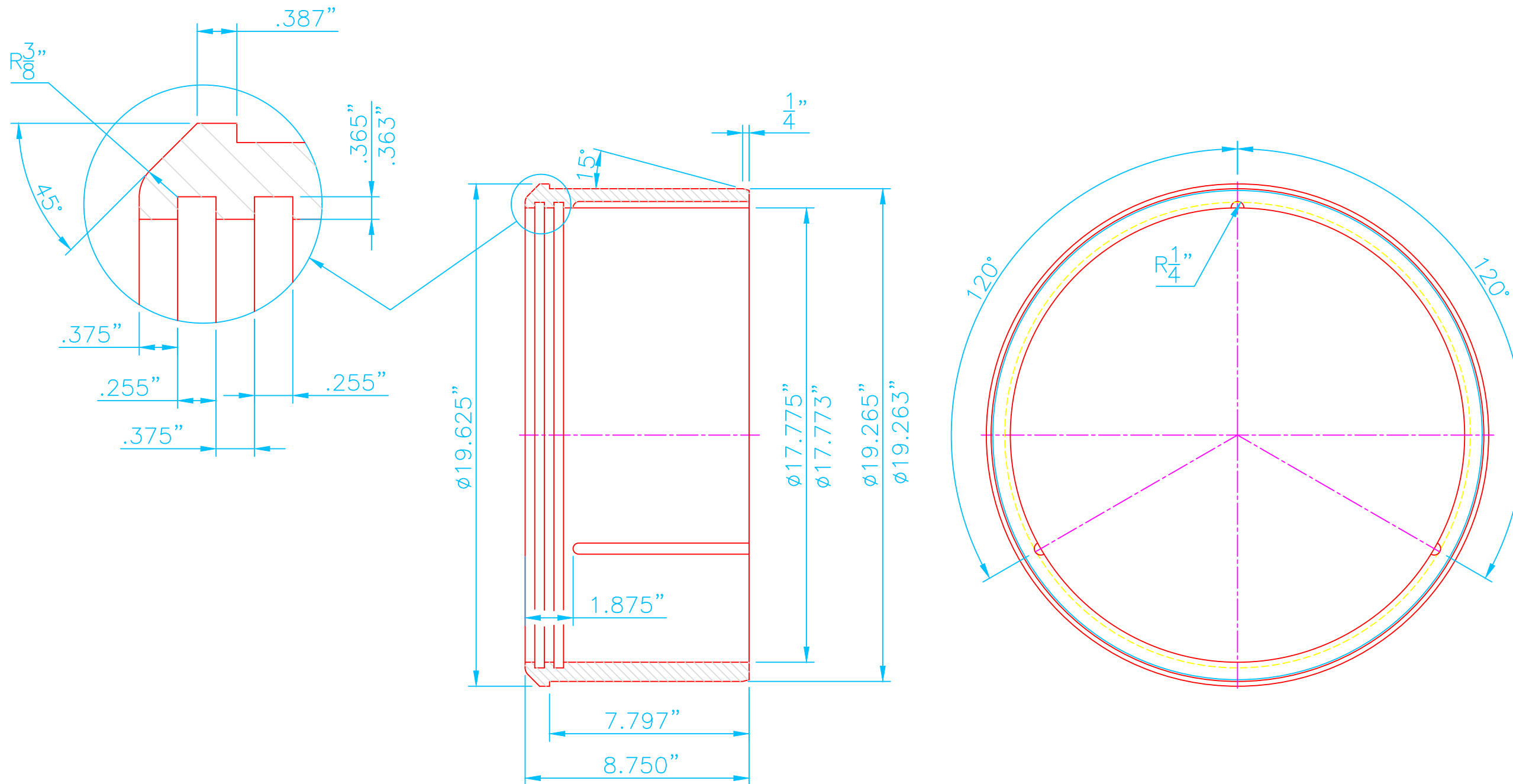

FRONT AND REAR BUSHINGS

MAT'L: BUSHING - 660 BRONZE
 SEAL RING - TEFLON .250"THK.
 X 18.500±.002 O.D. X 17.750^{+.004}_{+.002} I.D.

TOLERANCES UNLESS OTHERWISE SPECIFIED		Vincent CORPORATION TAMPA, FLORIDA	
FRACT.	DECIM.	ANGUL.	VP-30 PRESS CONE BUSHING FOR REPLACEMENT
± 1/32	± .004	± .5°	
APPROVALS	DATE	THIS PRINT IS THE PROPERTY OF VINCENT CORPORATION AND IS RECALLABLE AT ANY TIME. IT MUST NOT BE COPIED OR USED DETRIMENTALLY TO OUR INTERESTS.	
DRAWN EG	05/19/10	SIZE B	DRAWING NO. 94298-1
CHECKED		SCALE N.T.S. DO NOT SCALE DWG. SHEET	
COMP. NAME	07037_Master		
W. O. NO.	07037		

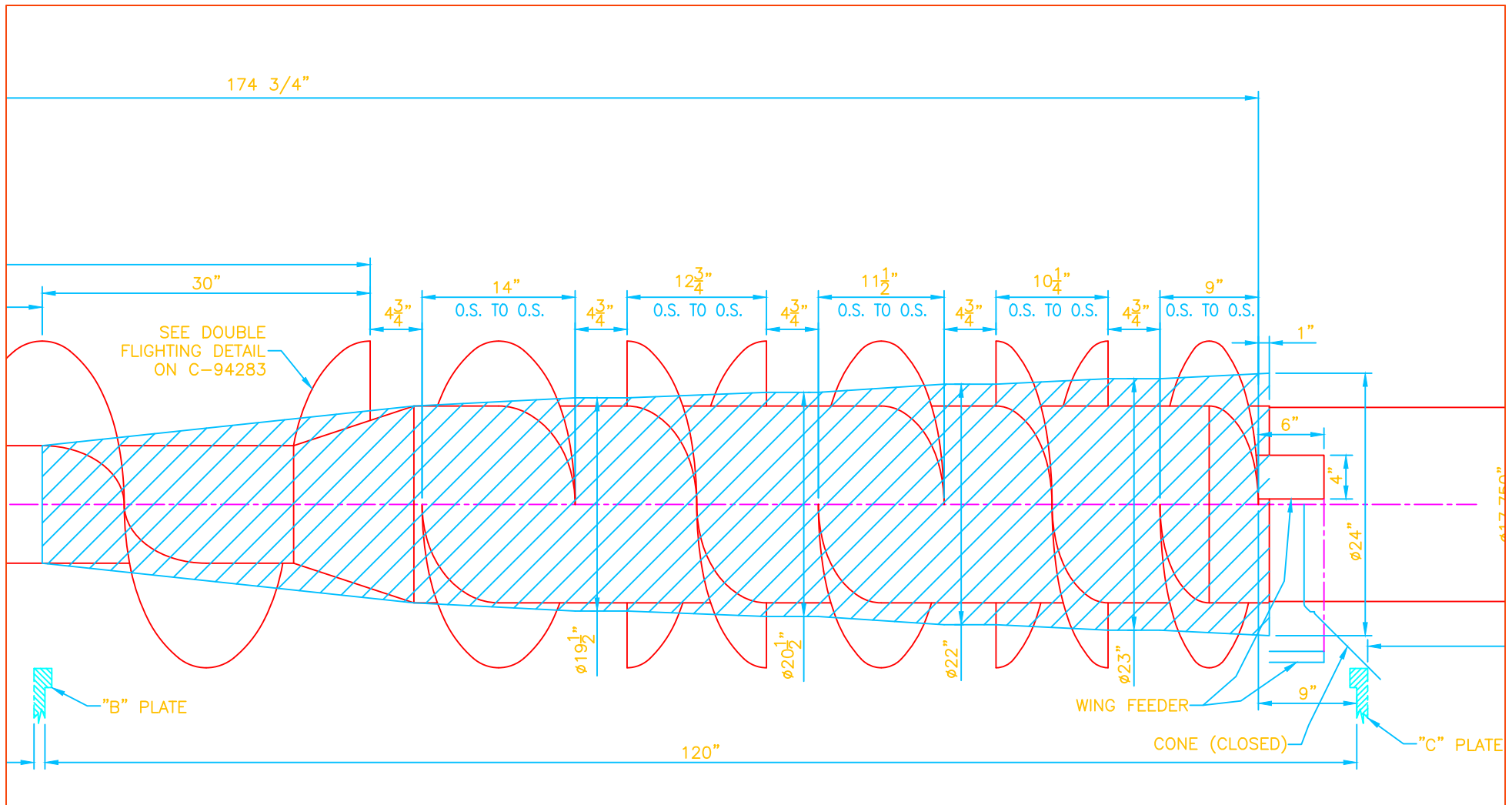

Vincent CORPORATION
TAMPA, FLORIDA

VP-30 PRESS
STEP SHAFT
FROM 27% TO 59%

DRAWN	EG	08/19/10	SIZE	DRAWING NO.
COMP. NAME	07037_Master		A	81910
W. O. NO.	SCALE		N. T. S.	SHEET

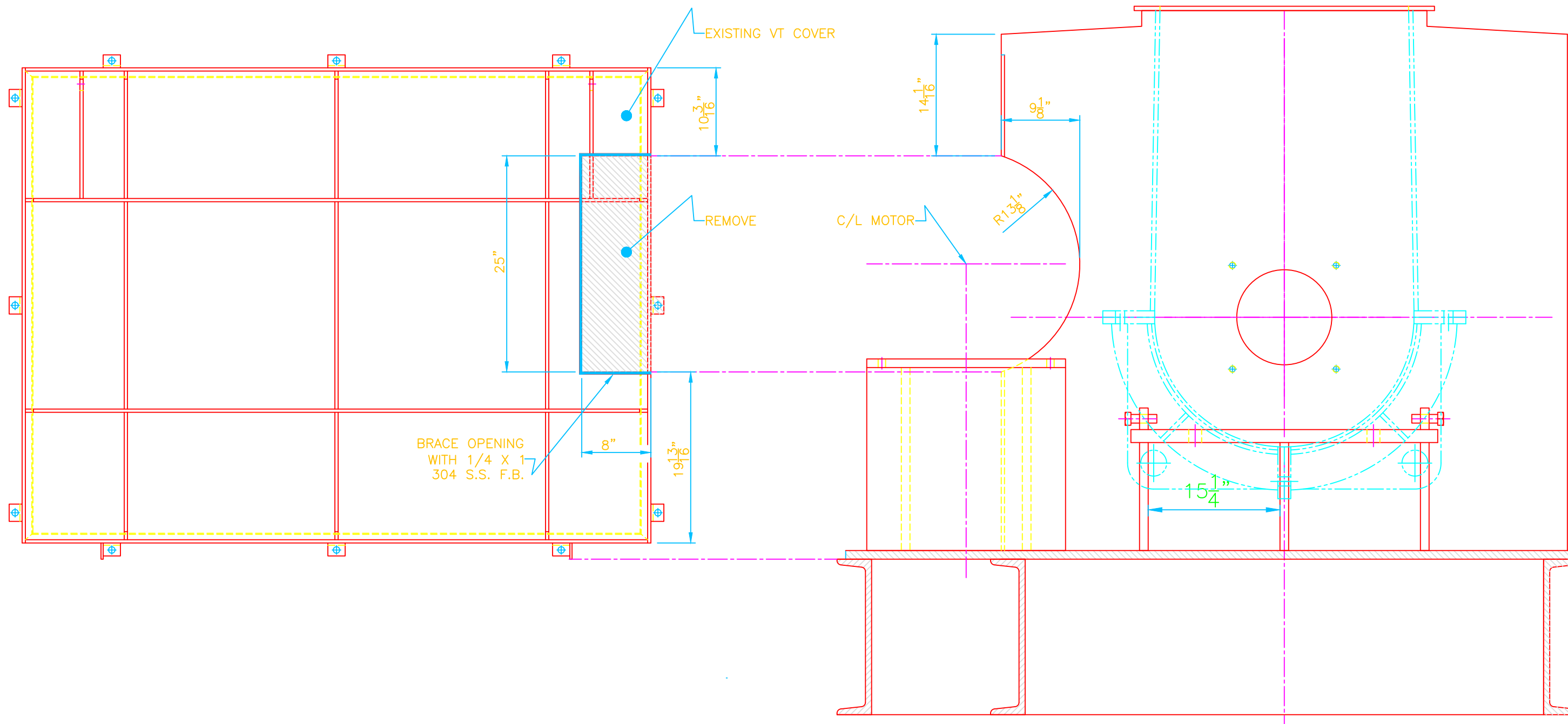

"A" PLATE LOOKING FROM REDUCER

TOLERANCES UNLESS OTHERWISE SPECIFIED			Vincent CORPORATION TAMPA, FLORIDA	
FRACT.	DECIM.	ANGUL.		
± 1/32	± .004	± .5°	VP-30 PRESS "A" PLATE AND VT COVER MODIFICATION	
APPROVALS	DATE			
DRAWN	EG	8/21/2015	THIS PRINT IS THE PROPERTY OF VINCENT CORPORATION AND IS RECALLABLE AT ANY TIME. IT MUST NOT BE COPIED OR USED DETRIMENTALLY TO OUR INTERESTS.	
CHECKED				
COMP. NAME	07037_Master		SIZE	DRAWING NO.
W. O. NO.	15361		B	15361-01
			SCALE	SHEET
			N. T. S.	DO NOT SCALE DWG.

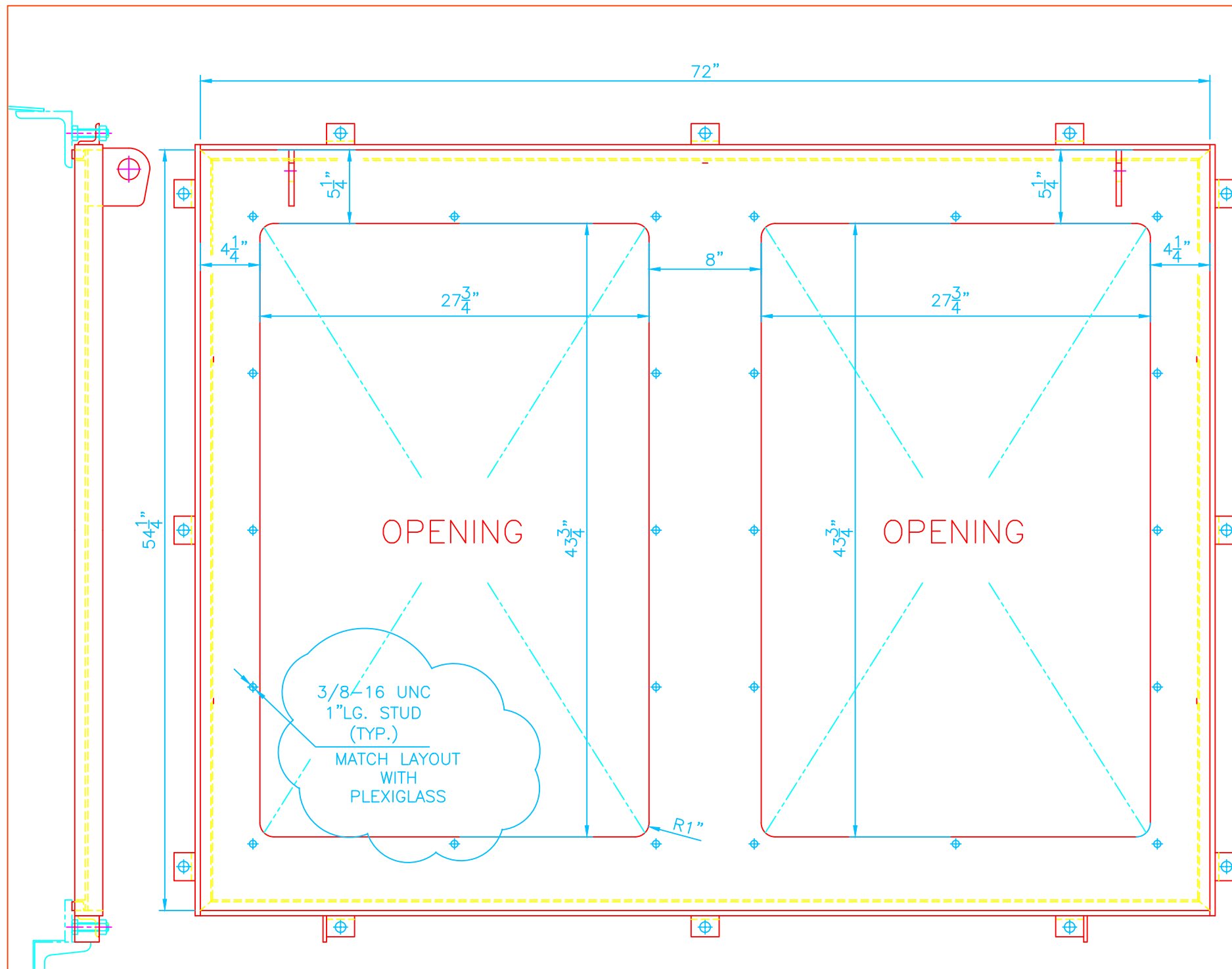

SIDE COVER MODIFICATION

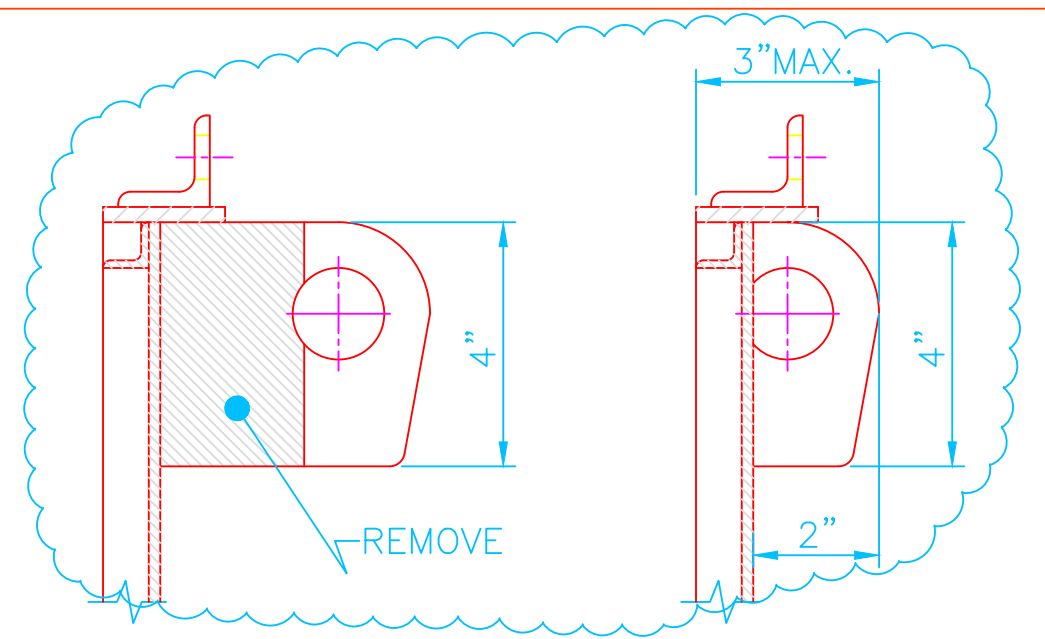

LIFTING LUG MODIFICATION

3/8-16 UNC, 1" LG
STUD WITH NUT,
RUBBER AND FLAT
WASHERS

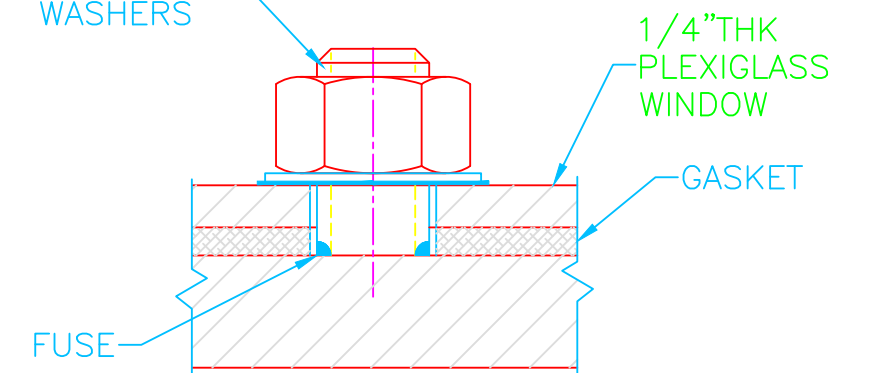

WINDOW ATTACHEMENT

N.T.S.
(TYP.)

MODIFICATION OF 10/5/2015
SEE CLOUDS

TOLERANCES UNLESS OTHERWISE SPECIFIED			Vincent CORPORATION TAMPA, FLORIDA	
FRACT.	DECIM.	ANGUL.		
± 1/32	± .004	± .5°	VP-30 PRESS SIDE COVER MODIFICATION	
APPROVALS	DATE			
DRAWN	EG	10/5/2015	THIS PRINT IS THE PROPERTY OF VINCENT CORPORATION AND IS RECALLABLE AT ANY TIME. IT MUST NOT BE COPIED OR USED DETRIMENTALLY TO OUR INTERESTS.	
CHECKED				
COMP. NAME	07037_Master		SIZE	DRAWING NO.
W. O. NO.	15220		B	15220-01B
SCALE N.T.S.			DO NOT SCALE DWG.	SHEET

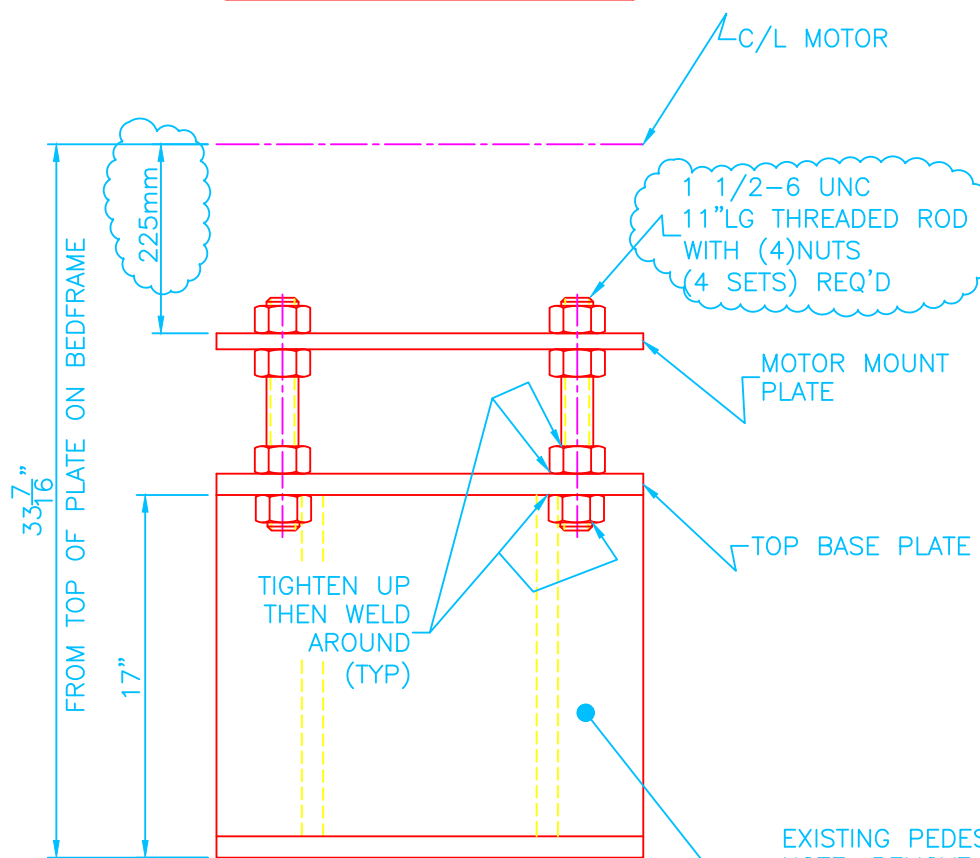
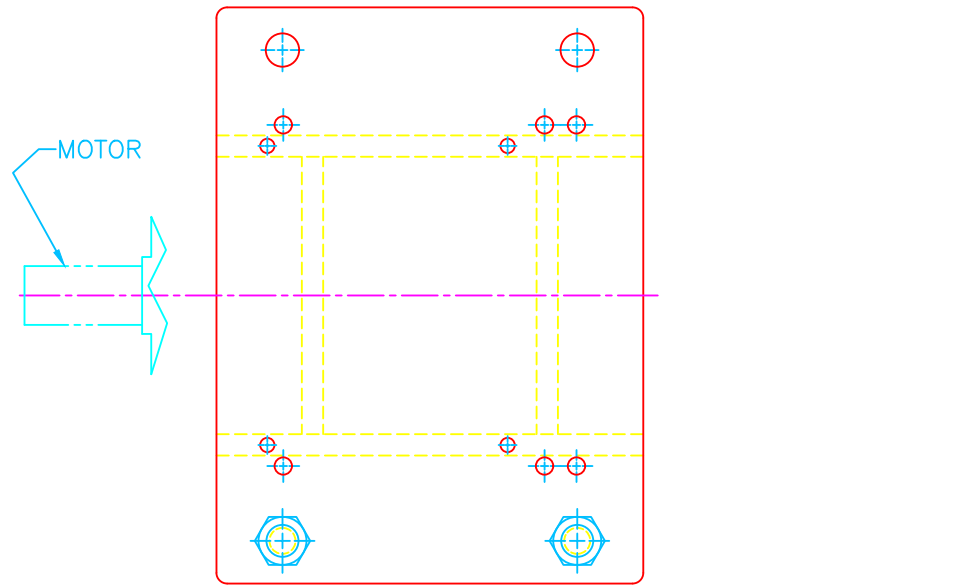

MOTOR PEDESTAL

1 1/2-6 UNC
11" LG THREADED ROD
WITH (4) NUTS
(4 SETS) REQ'D

EXISTING PEDESTAL
NOTE: REMOVE AND
TURN 180°
TRIM TO 17" HIGHT
AS SHOWN

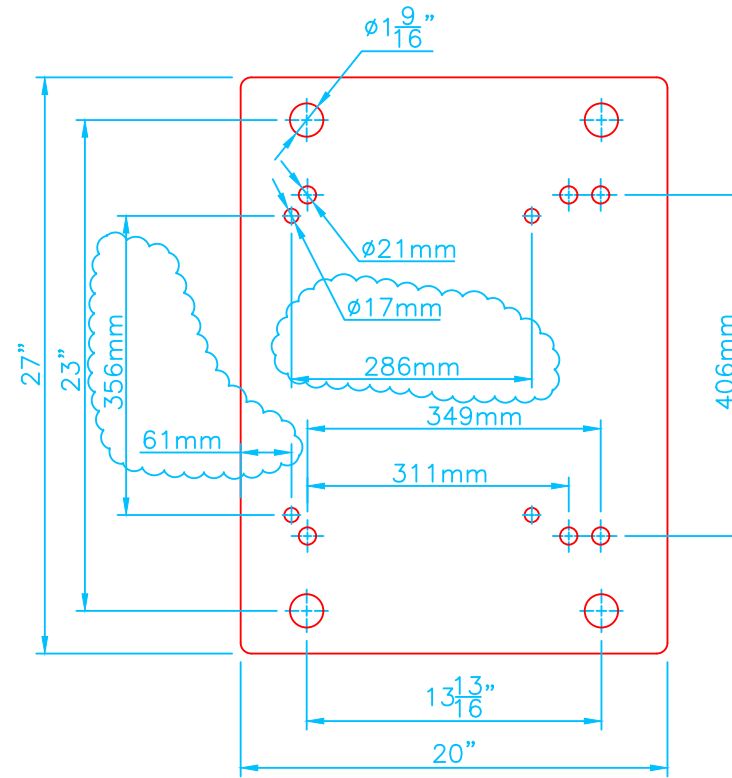

MOTOR MOUNT PLATE

MAT'L: 3/4" THK. M.S. PLATE

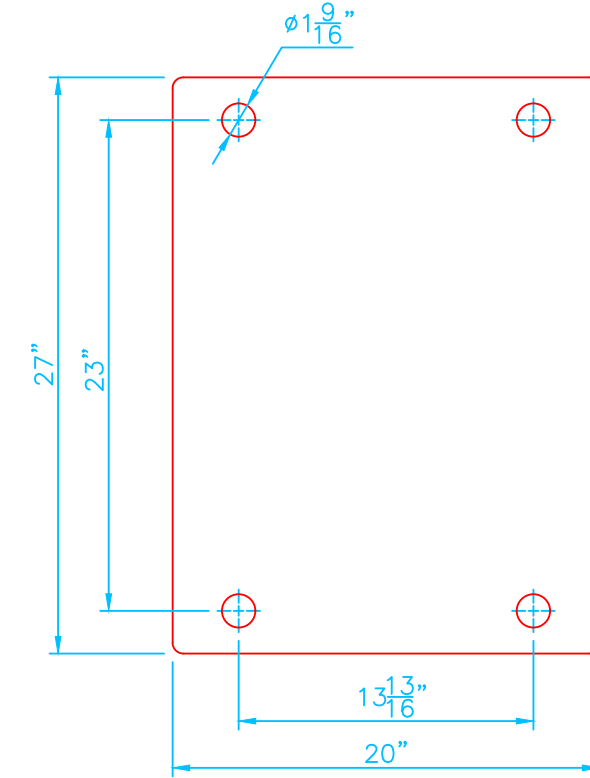

TOP BASE PLATE

MAT'L: 1" THK. M.S. PLATE

MODIFICATION OF 9/30/2015
SEE CLOUDS

TOLERANCES UNLESS OTHERWISE SPECIFIED			Vincent CORPORATION TAMPA, FLORIDA	
FRACT.	DECIM.	ANGUL.		
± 1/32	± .004	± .5°	VP-30 PRESS	
APPROVALS			MOTOR PEDESTAL	
DATE			S/N 07037-A,B	
DRAWN	EG	9/30/2015	THIS PRINT IS THE PROPERTY OF VINCENT CORPORATION AND IS RECALLABLE AT ANY TIME. IT MUST NOT BE COPIED OR USED DETRIMENTALLY TO OUR INTERESTS.	
CHECKED			SIZE	DRAWING NO.
COMP. NAME	07037_Master		B	15220-02A
W. O. NO.	15220		SCALE	45kW 750R
			DO NOT SCALE DWG.	SHEET

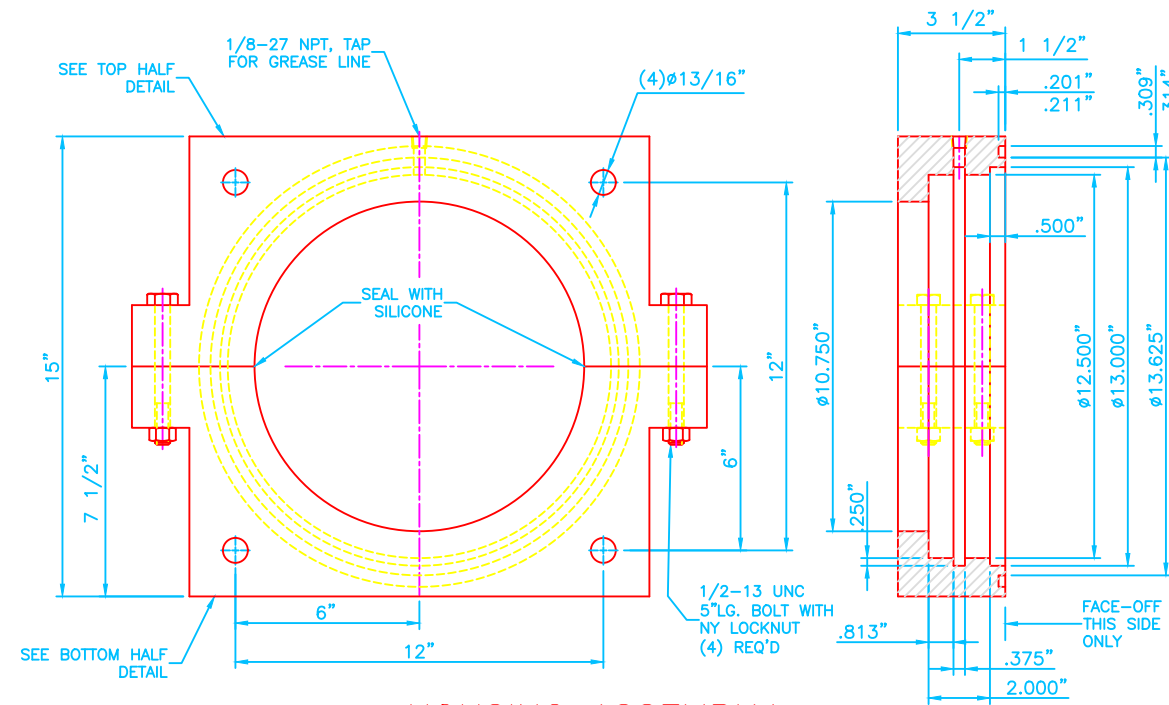

HOUSING ASSEMBLY

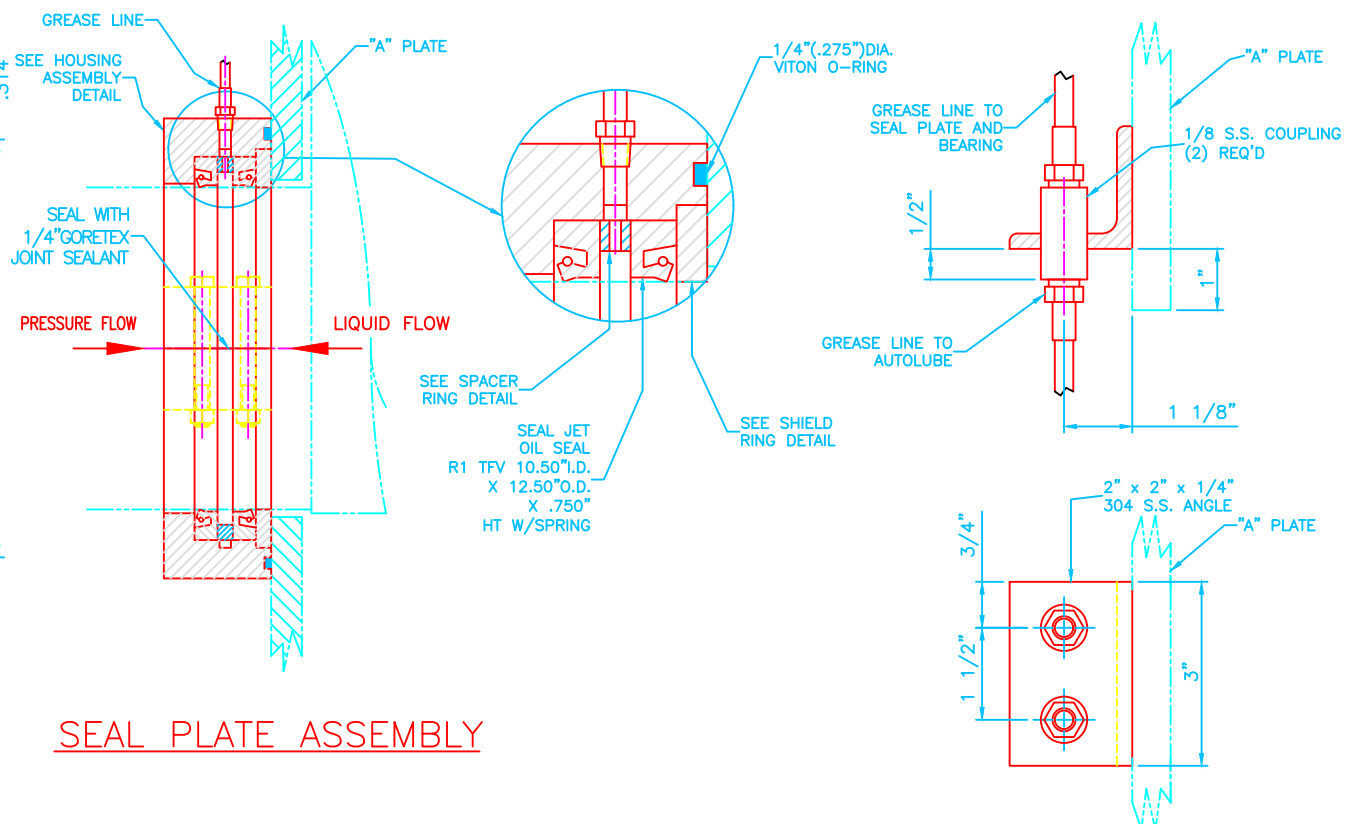

SEAL PLATE ASSEMBLY

GREASE FITTING BRACKET

N.T.S.

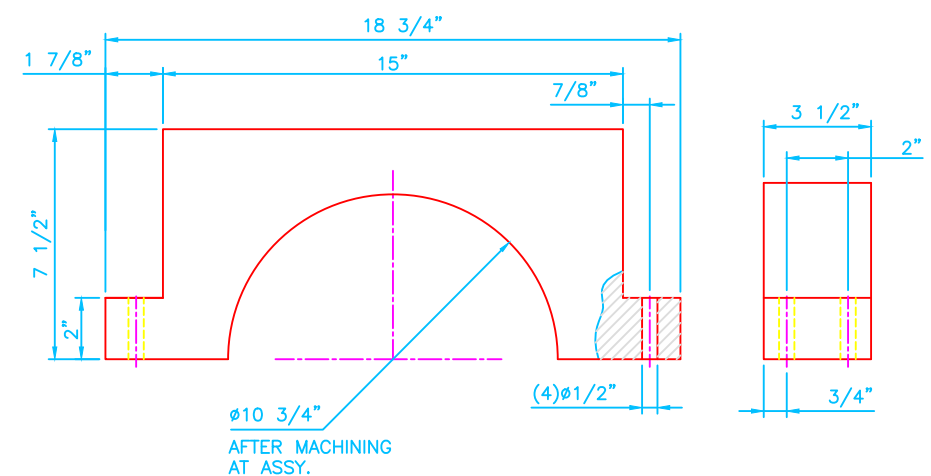

TOP HALF
 MAT'L: 3.50" THK., UHMW PLATE

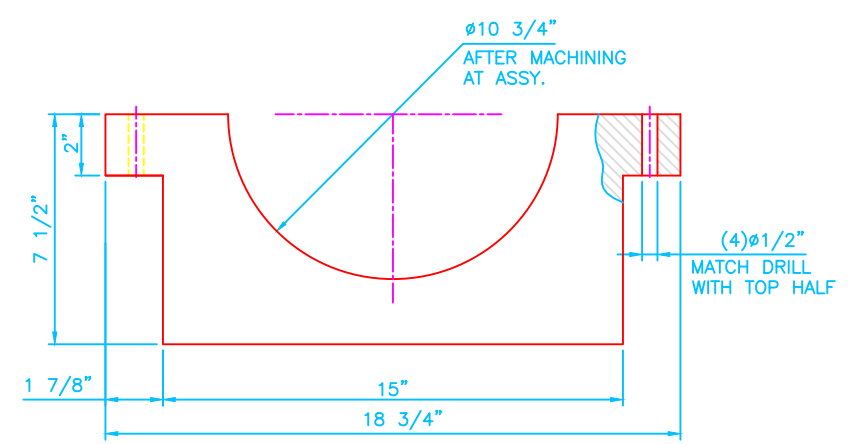

BOTTOM HALF
 MAT'L: 3.50" THK., UHMW PLATE

NOTE:
 1. ALL SHARP EDGES TO BE REMOVED AFTER MACHINING

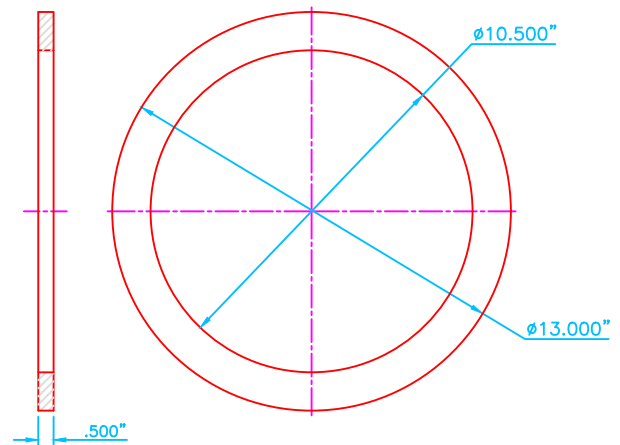

SHIELD RING
 MAT'L: UHMW PLATE

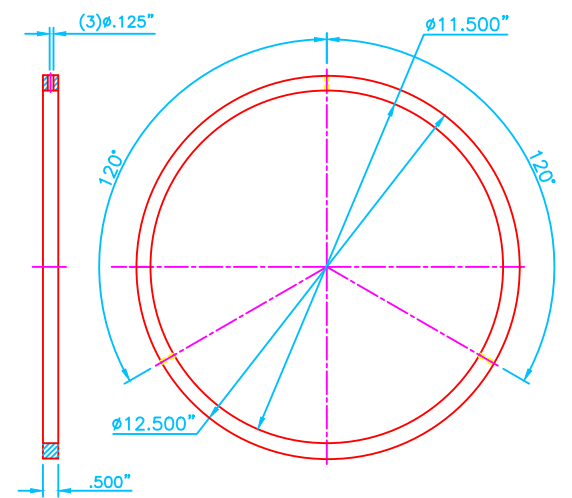

SPACER RING
 MAT'L: UHMW PLATE

TOLERANCES UNLESS OTHERWISE SPECIFIED:
 DECIMAL FOR MACHINING:
 ON SHAFT $-.004$ "
 ON HOLE $+.004$ "
 OTHERS $\pm .004$ "

TOLERANCES UNLESS OTHERWISE SPECIFIED			Vincent CORPORATION TAMPA, FLORIDA VP-30 PRESS SEAL PLATE ASSEMBLY S/N 07037-A,B	
FRACT.	DECIM.	ANGUL.		
$\pm 1/32$	$\pm .004$	$\pm .5^\circ$	EG	9/30/2015
COMP. NAME 07037_Master			CHECKED	DATE
W. O. NO. 15220			SCALE N.T.S.	DO NOT SCALE DWG.
			SIZE B	DRAWING NO. 15220-03
			SHEET	

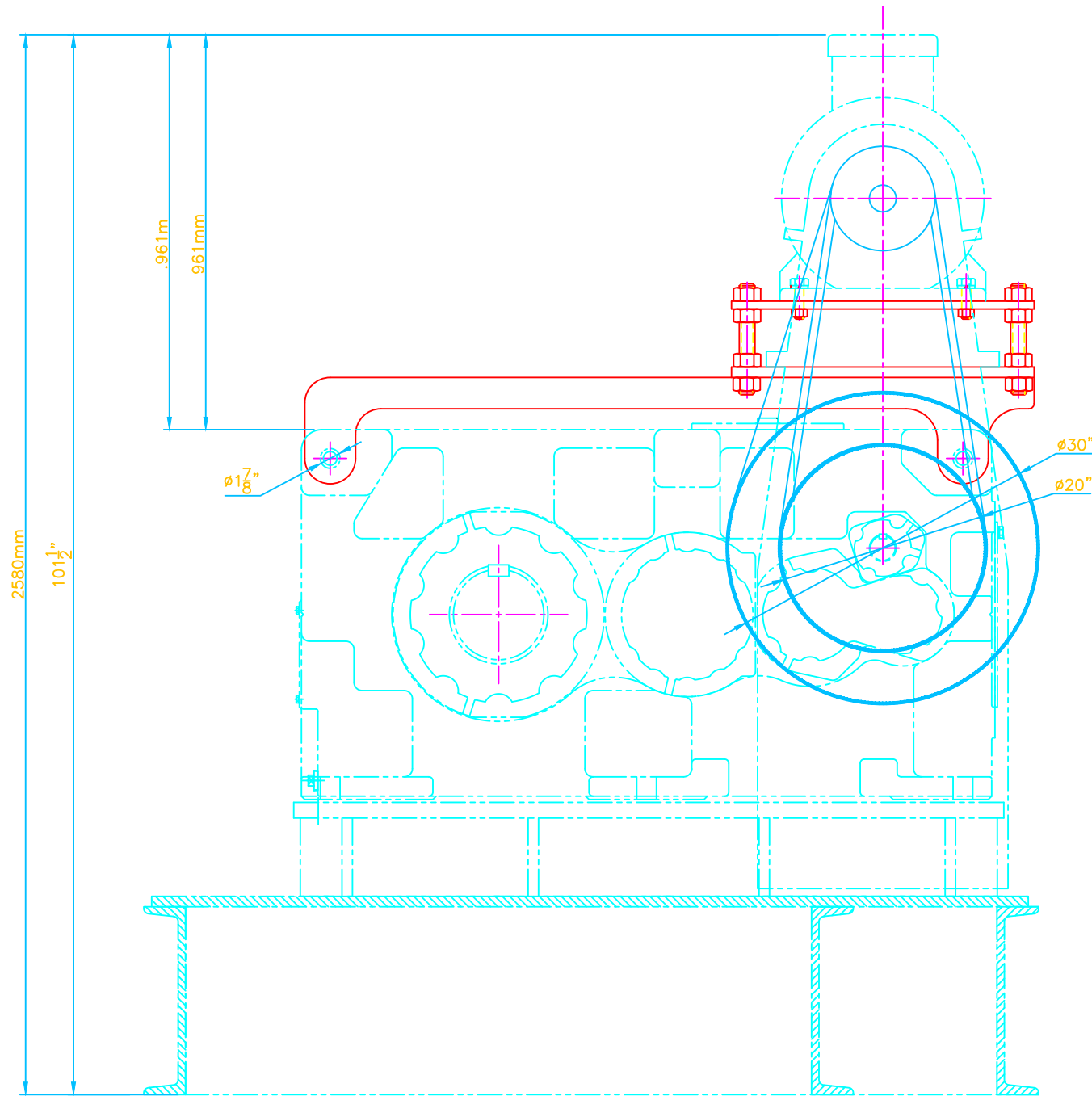
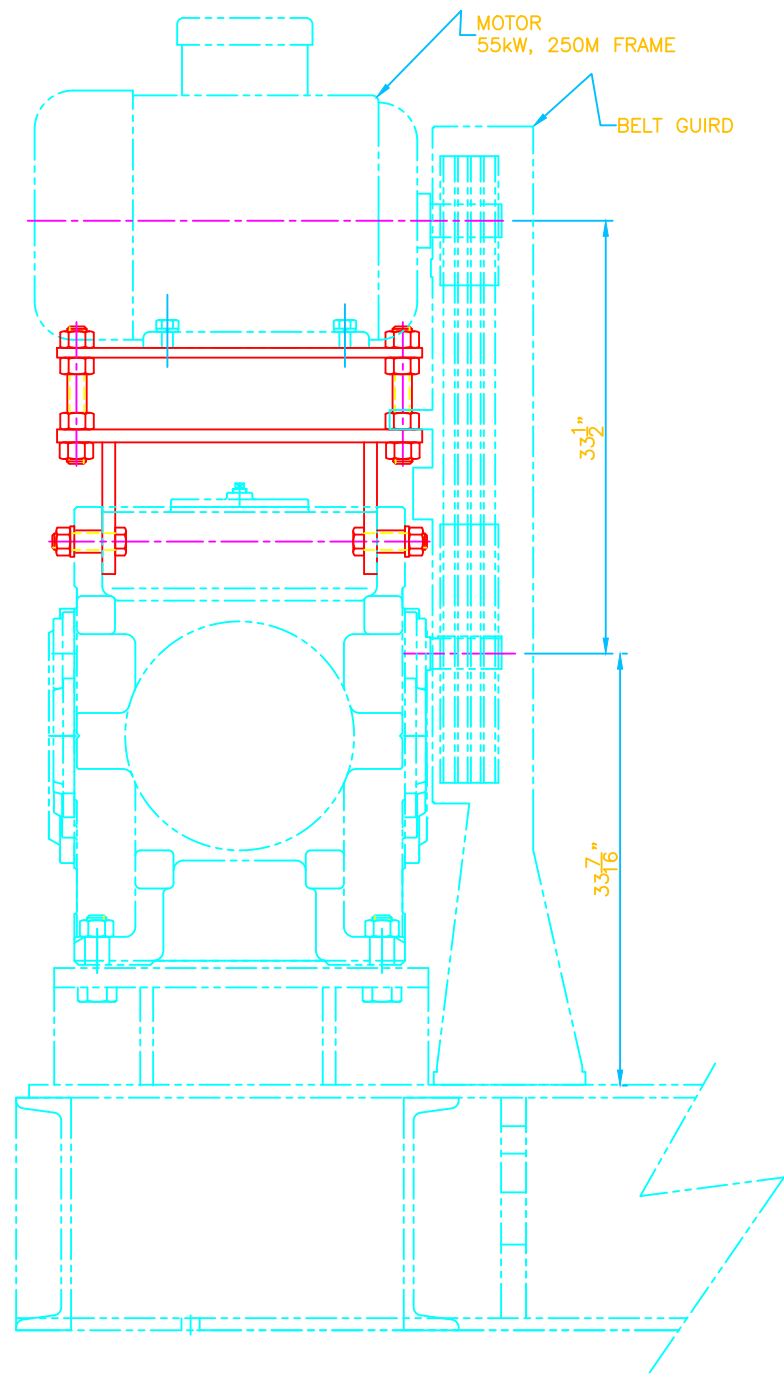

Vincent CORPORATION
TAMPA, FLORIDA

VP-30 PRESS
NEW MOTOR INSTALLATION
DIAGRAM

DRAWN	EG	10/21/2015	SIZE	DRAWING NO.
COMP. NAME	07037_Master		B	15220-13
W. O. NO.	15220	SCALE	N. T. S.	SHEET

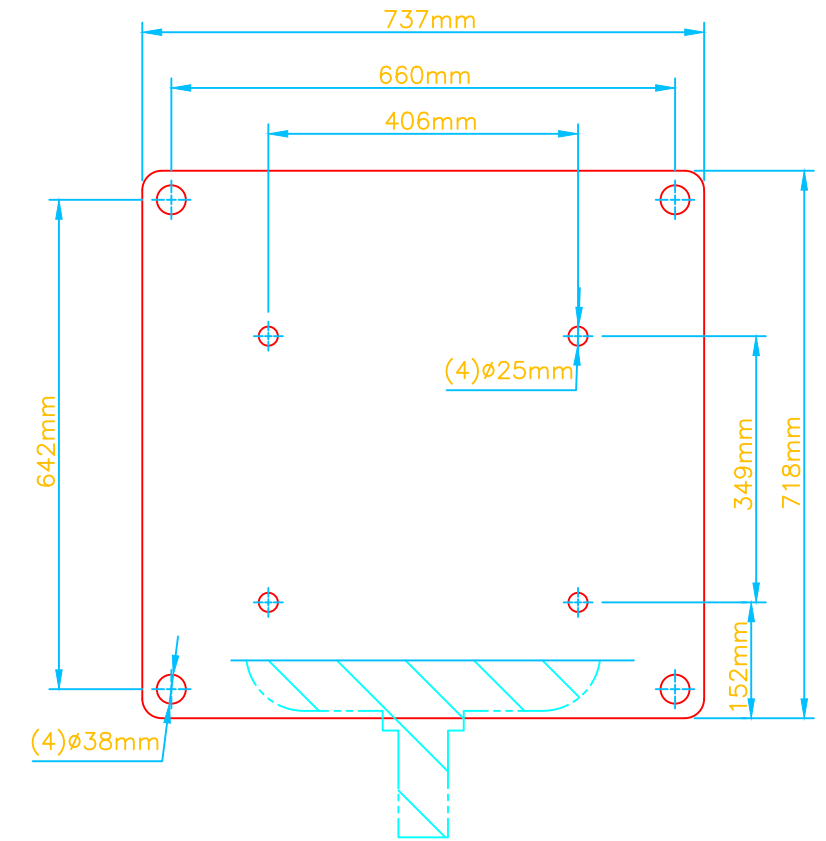
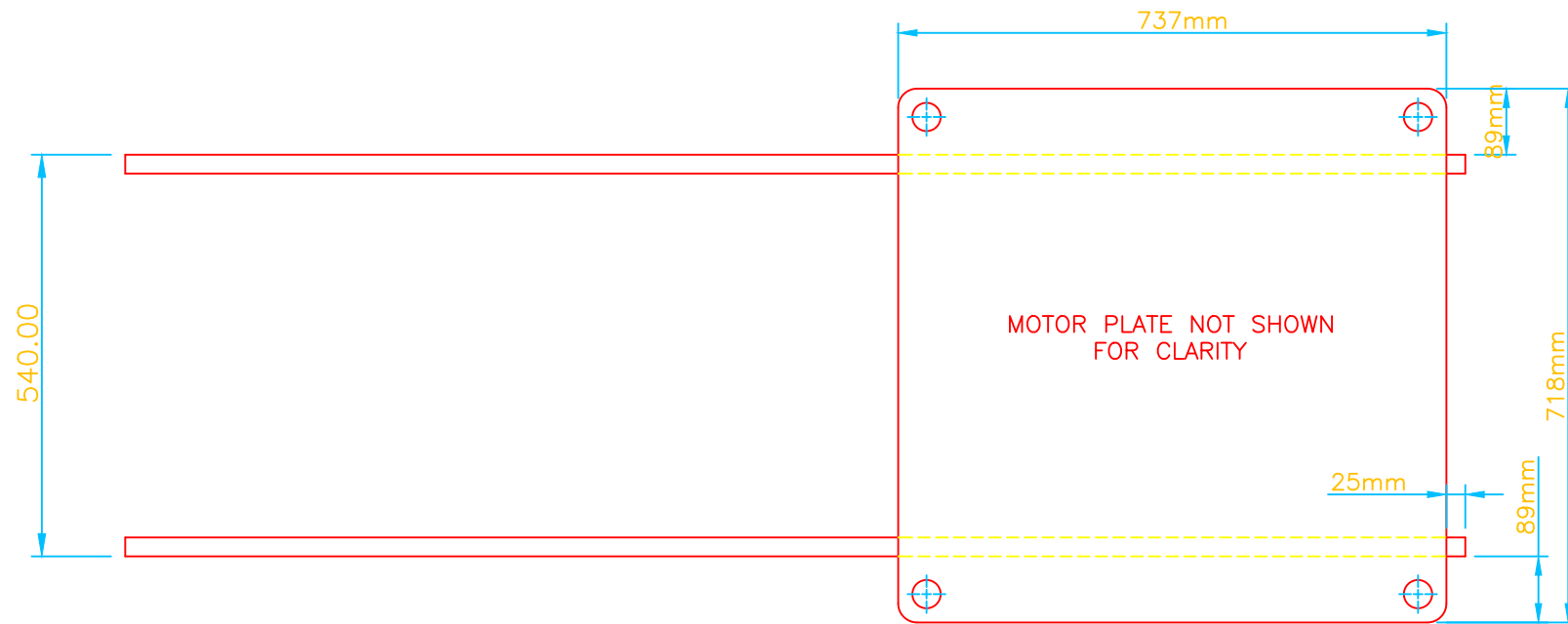

MOTOR PLATE

MAT'L: 3/4"(19mm)THK. M.S. PLATE

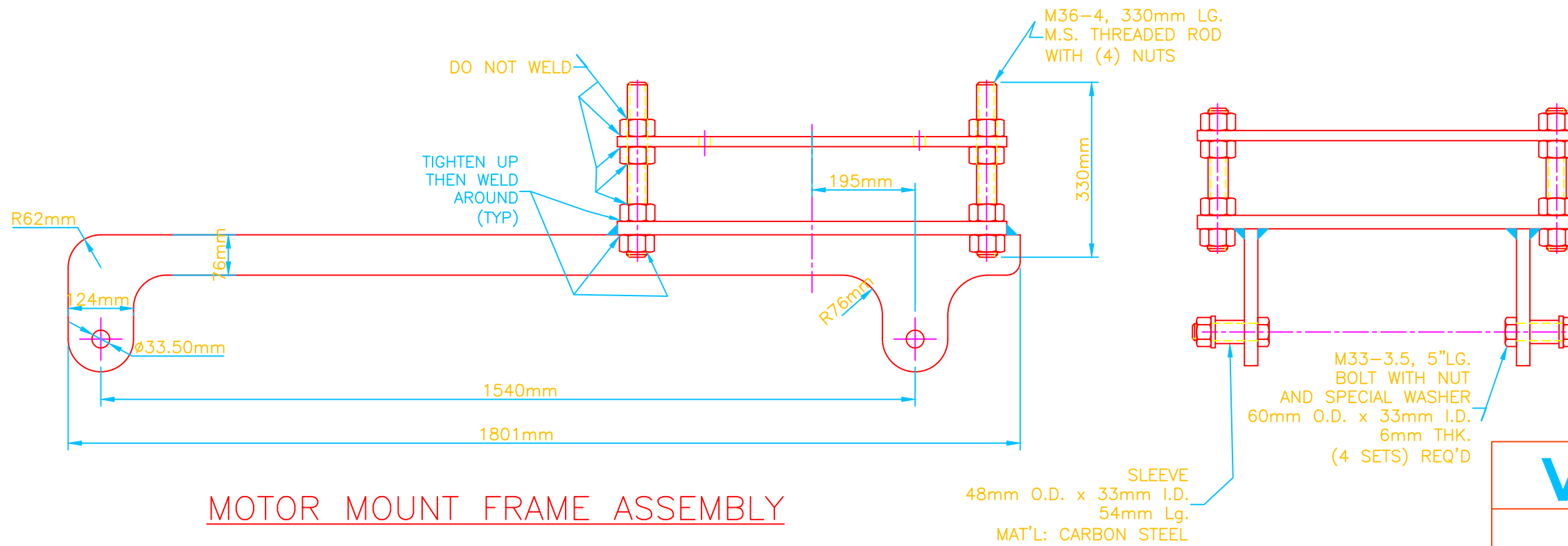

MOTOR MOUNT FRAME ASSEMBLY

NOTE: USE REDUCER IN THE FIELD AS A FABRICATING FIXTURE

Vincent		CORPORATION	
		TAMPA, FLORIDA	
VP-30 PRESS MOTOR MOUNT PLATE ASSEMBLY			
DRAWN	EG	3/17/2016	SIZE
COMP. NAME	07037_Master	B	DRAWING NO.
W. O. NO.	15220	SCALE	N. T. S.
			SHEET
			15220-17

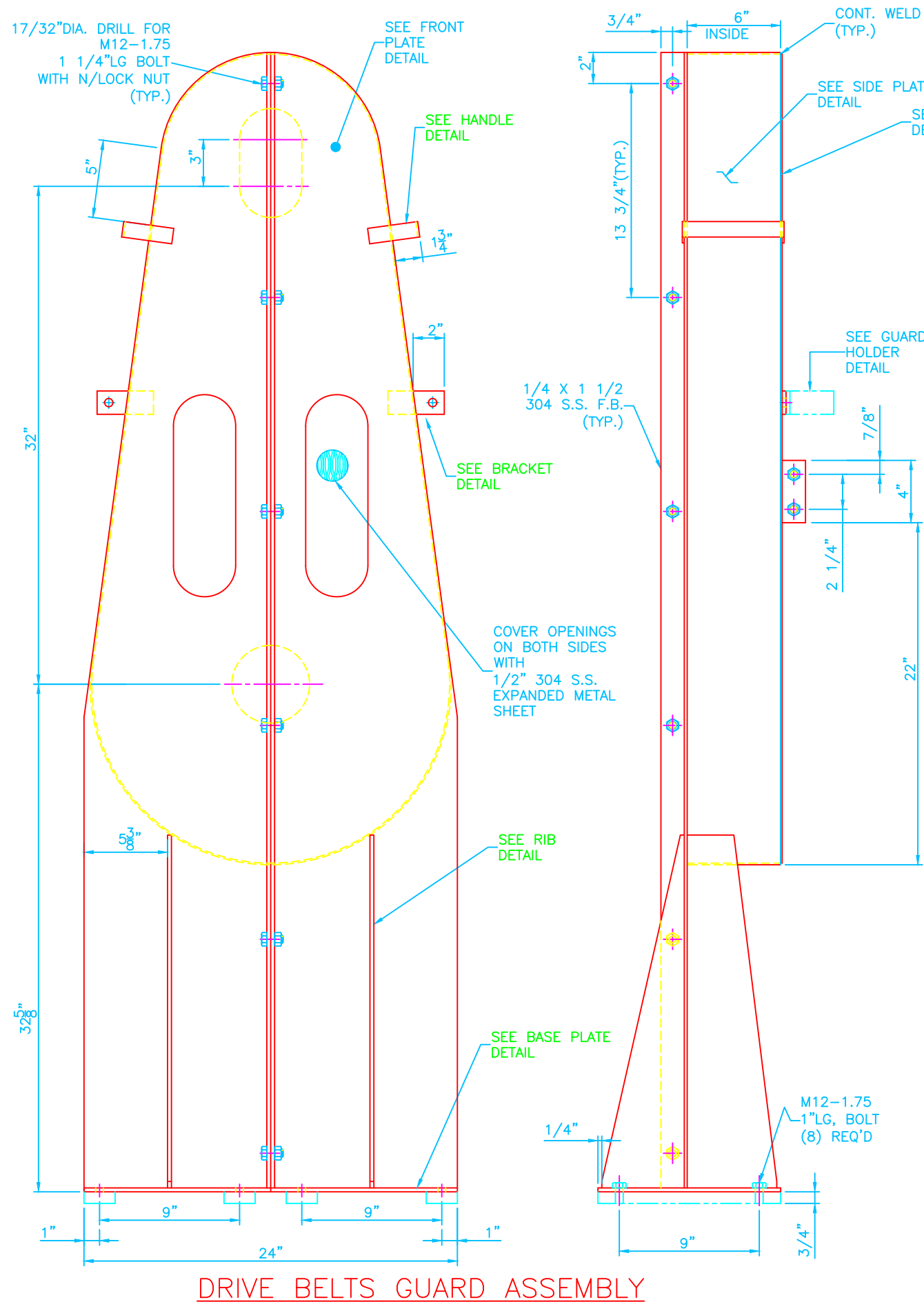

DRIVE BELTS GUARD ASSEMBLY

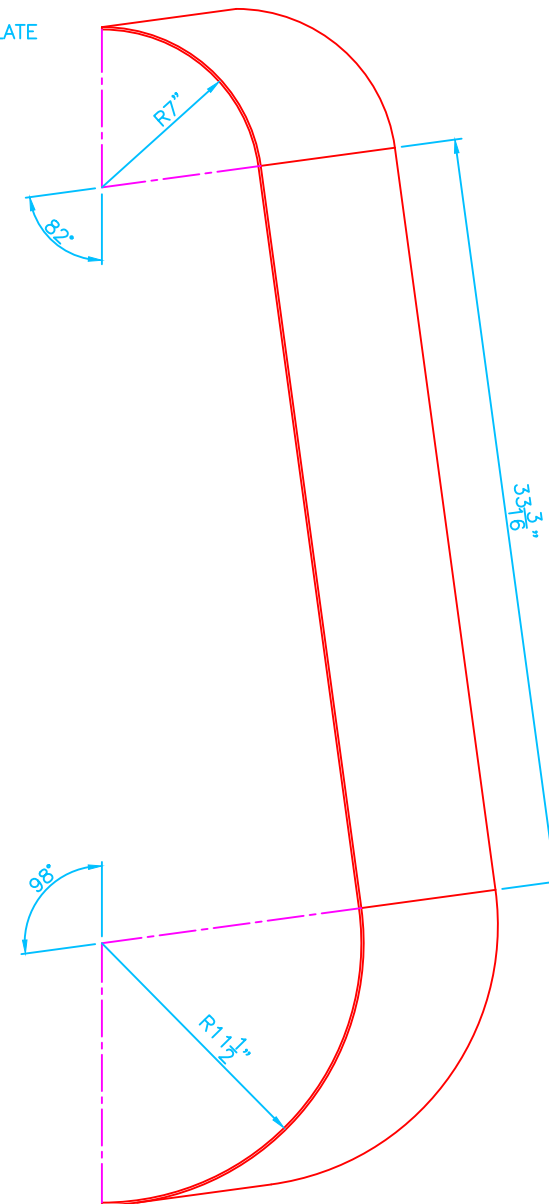

SIDE PLATE

MAT'L: 12GA, 304 S.S. SHEET
(2) REQ'D

SEE PARTS ON B-15220-19

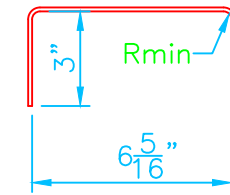

HANDLE

MAT'L: 1/8 X 1, 304 S.S. F.B.
(2) REQ'D

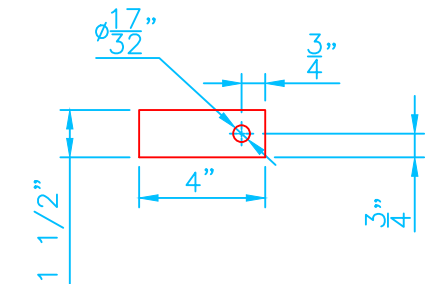

BRACKET

MAT'L: 1/4 X 1 1/2, 304 S.S. F.B.
(2) REQ'D

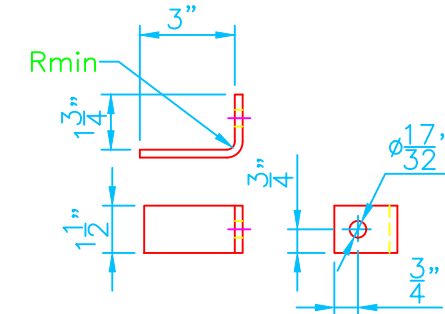

GUARD HOLDER

MAT'L: 1/4 X 1 1/2, 304 S.S. F.B.
(2) REQ'D
TO BE WELDED TO MOTOR SUPPORT
AT ASSY.

Vincent CORPORATION
TAMPA, FLORIDA

VP-30 PRESS
DRIVE BELTS GUARD
ASSEMBLY

DRAWN	EG	3/17/2016	SIZE	DRAWING NO.
COMP. NAME	07037_Master		B	15220-18
W. O. NO.	15220	SCALE	N.T.S.	SHEET

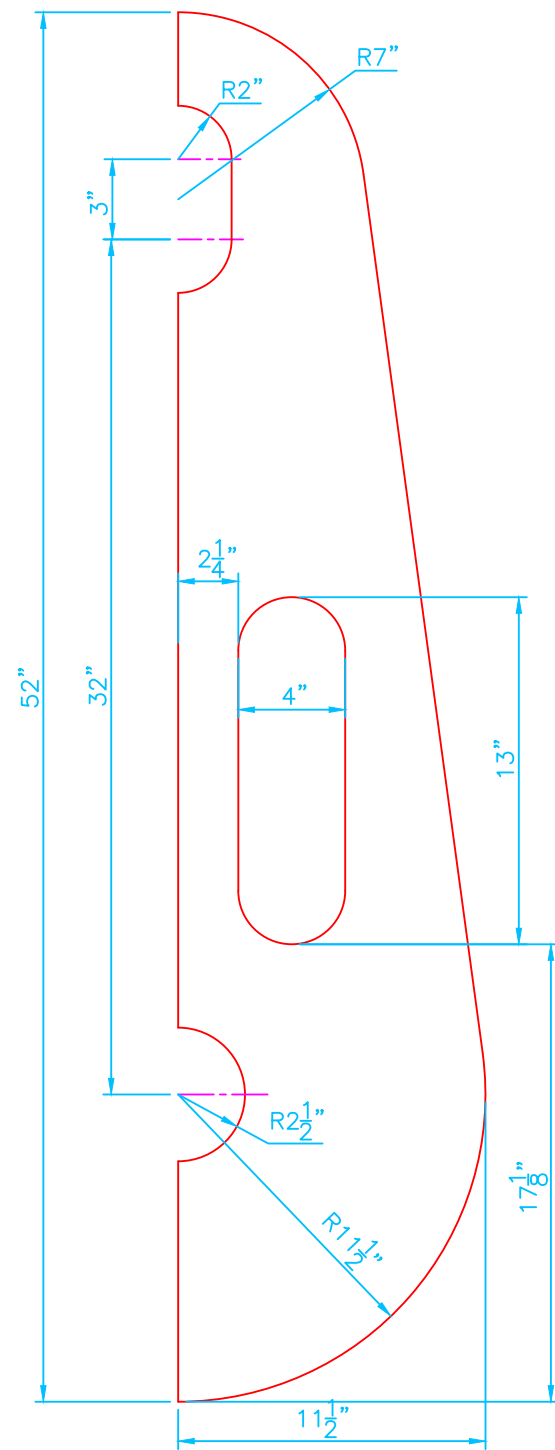

BACK PLATE

MAT'L: 12GA, 304 S.S. SHEET
(2) REQ'D

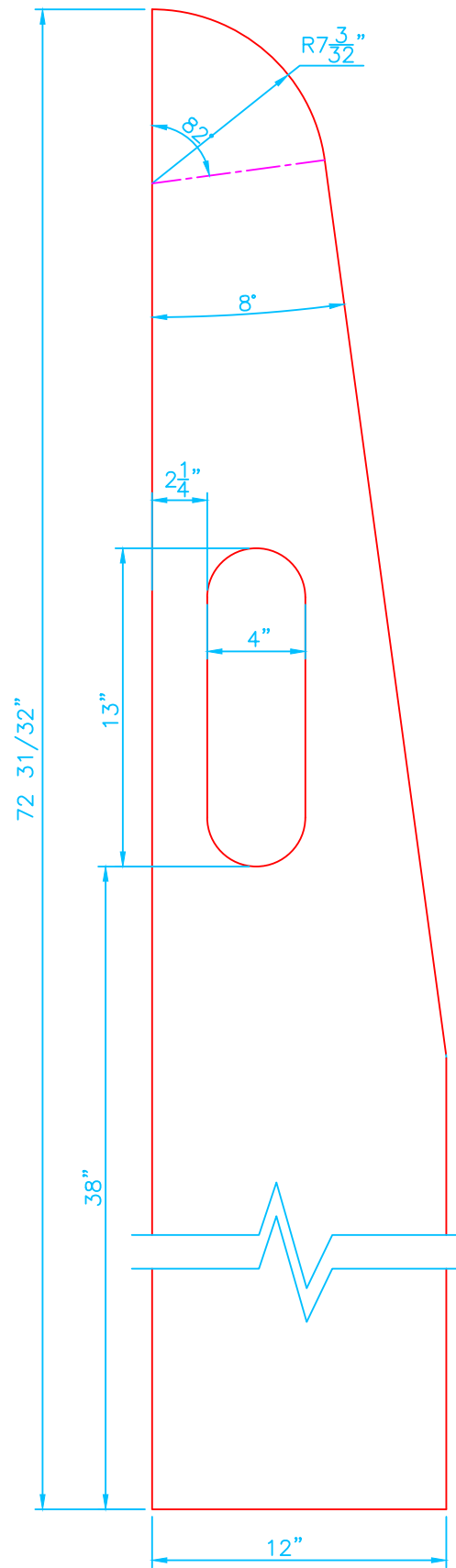

FRONT PLATE

MAT'L: 3/16"THK. 304 S.S. PLATE
(2) REQ'D

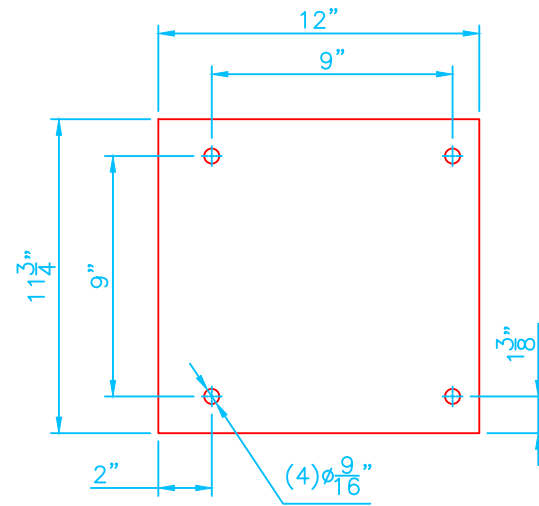

COVER BASE PLATE

MAT'L: 1/4"THK, 304 S.S. PLATE
(2) REQ'D

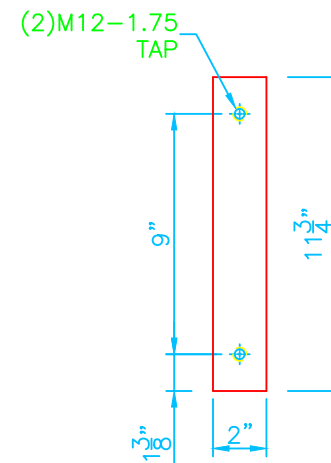

BASE PAD

MAT'L: 3/4"THK, M.S. PLATE
(4) REQ'D

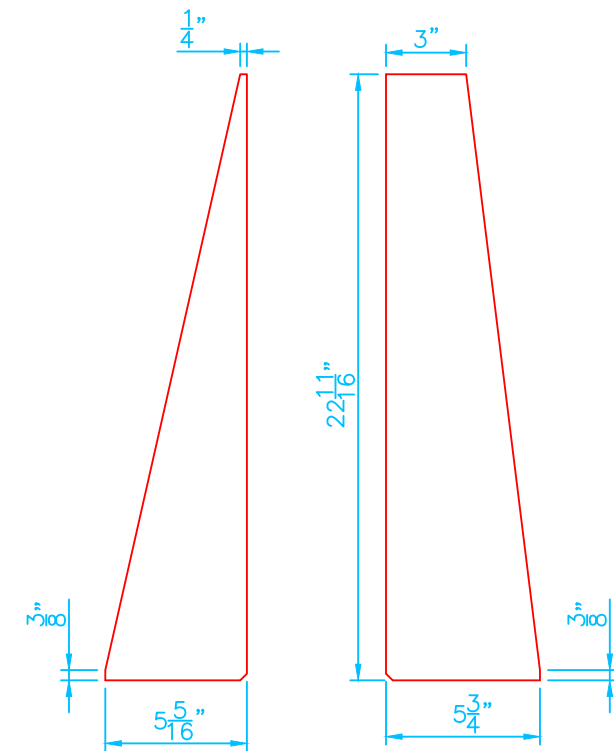

RIB

MAT'L: 1/4"THK, 304 S.S. PLATE
(2 OF EACH) REQ'D

Vincent		CORPORATION	
		TAMPA, FLORIDA	
VP-30 PRESS DRIVE BELTS GUARD PARTS DETAILS			
DRAWN	EG	3/17/2016	SIZE
COMP. NAME	07037_Master	B	DRAWING NO.
W. O. NO.	15220	SCALE	N. T. S.
		SHEET	
		15220-19	

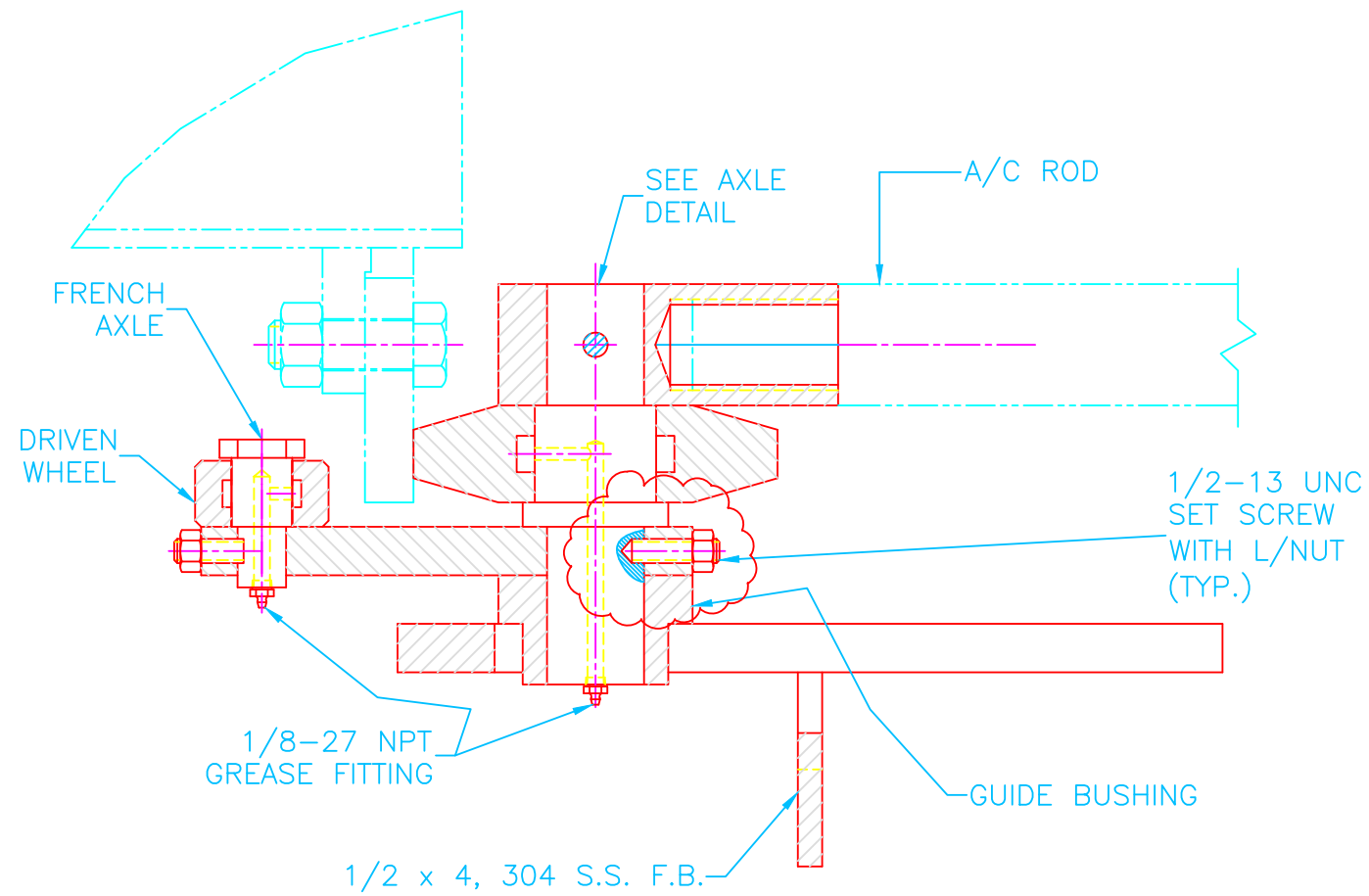

CONE DRIVE MECHANISM

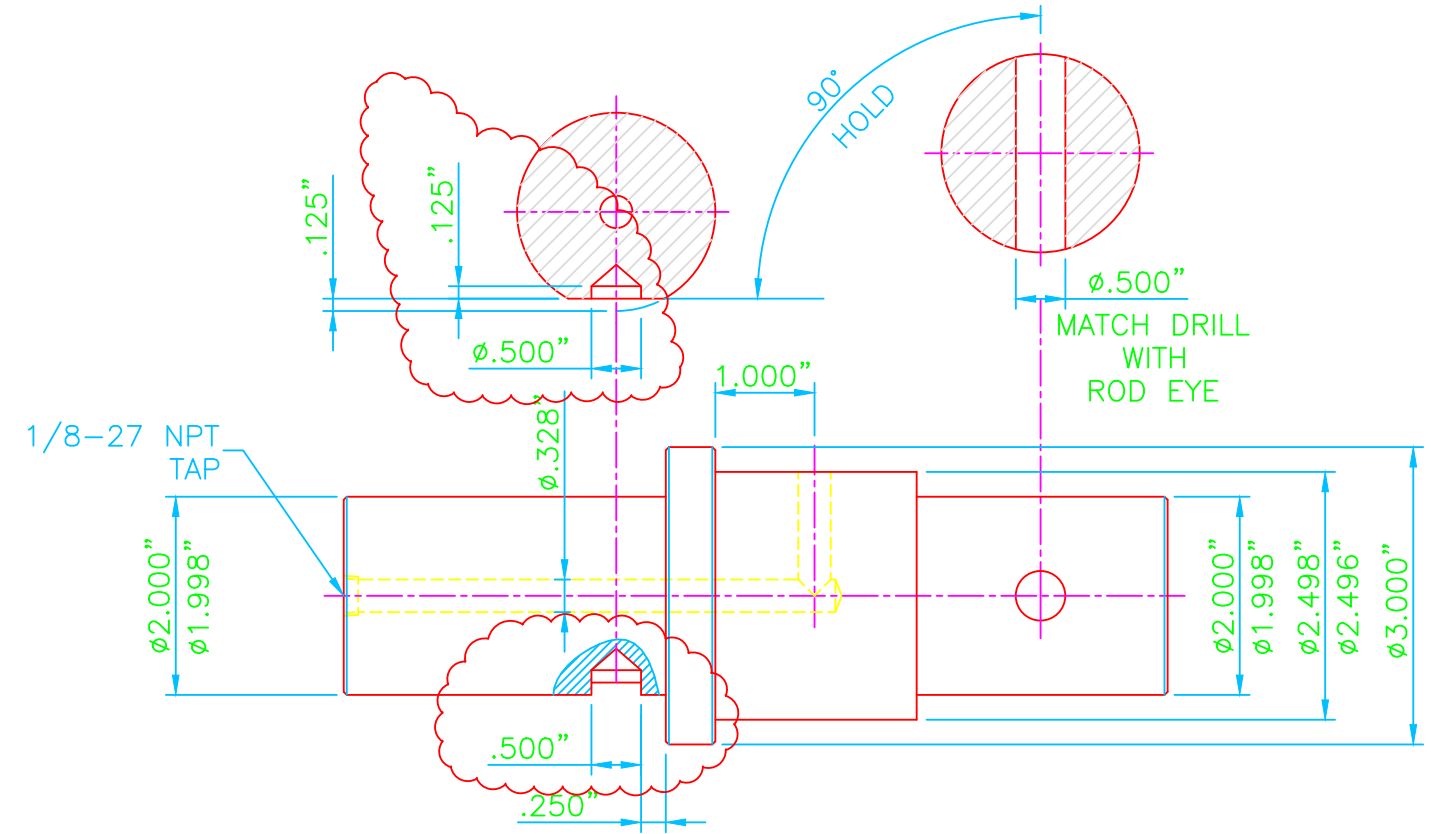

AXLE

N.T.S.
 MAT'L: 3"DIA. 304 S.S. ROD
 (2) REQ'D

AXLE MODIFICATION
 FOR ALL (6) VP-30 PRESSES
 SEE CLOUDS

TOLERANCES UNLESS OTHERWISE SPECIFIED			Vincent CORPORATION TAMPA, FLORIDA	
FRACT.	DECIM.	ANGUL.		
± 1/32	± .004	± .5°	VP-30 PRESS CONE DRIVE MECHANISM PARTS DETAILS	
APPROVALS	DATE			
DRAWN EG	03/23/07		THIS PRINT IS THE PROPERTY OF VINCENT CORPORATION AND IS RECALLABLE AT ANY TIME. IT MUST NOT BE COPIED OR USED DETRIMENTALLY TO OUR INTERESTS.	
CHECKED				
COMP. NAME	07037_Master		SIZE	DRAWING NO.
W. O. NO.	07037		B	94290
SCALE N.T.S.			DO NOT SCALE DWG.	SHEET

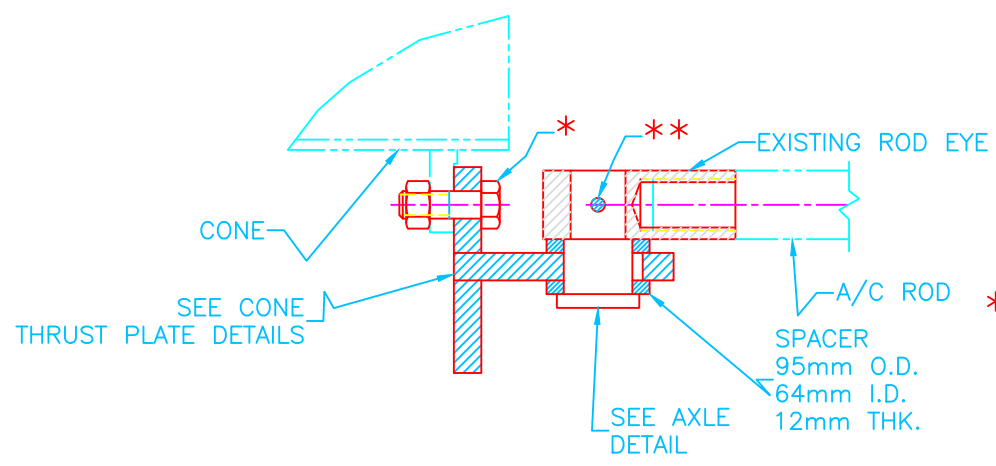
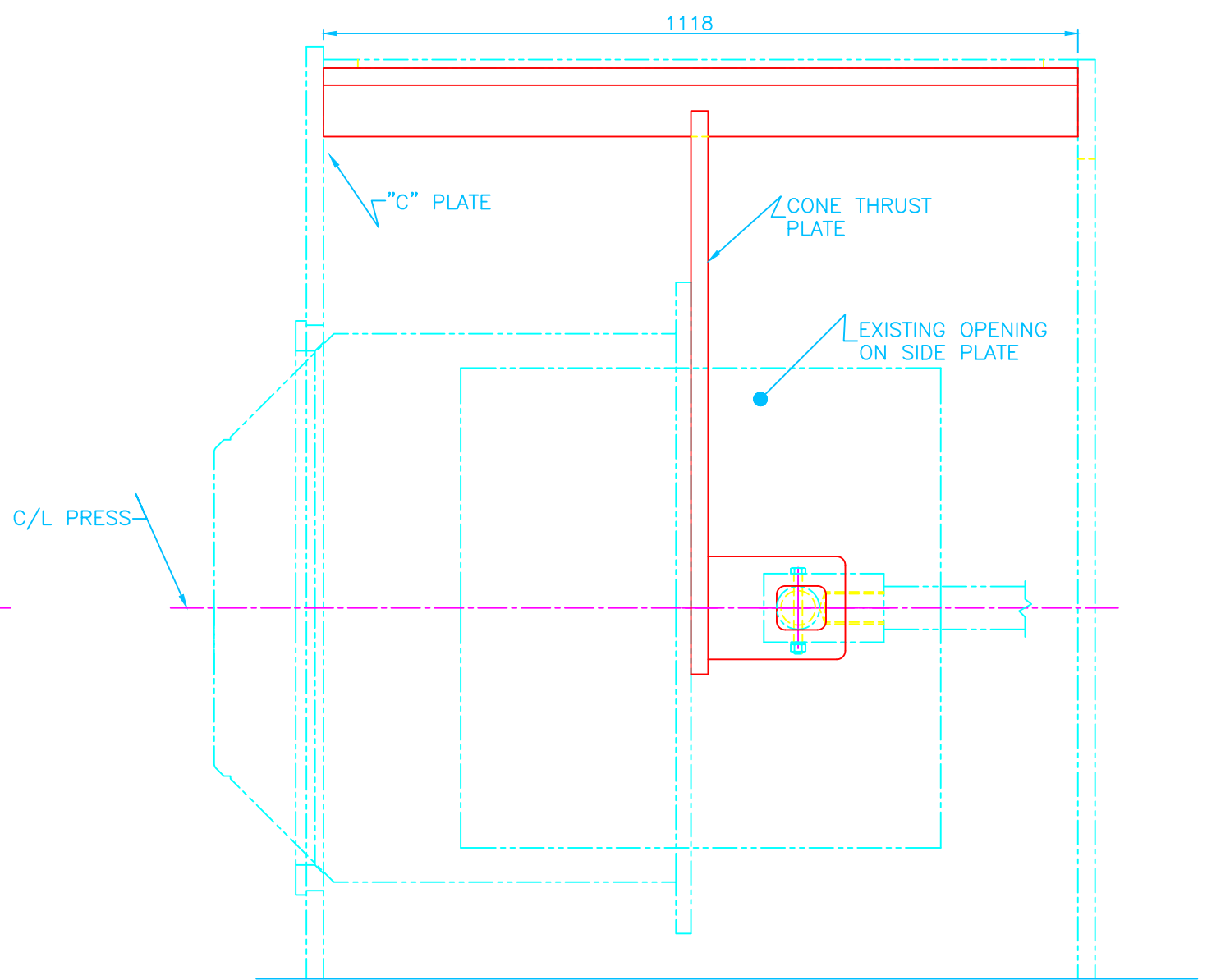
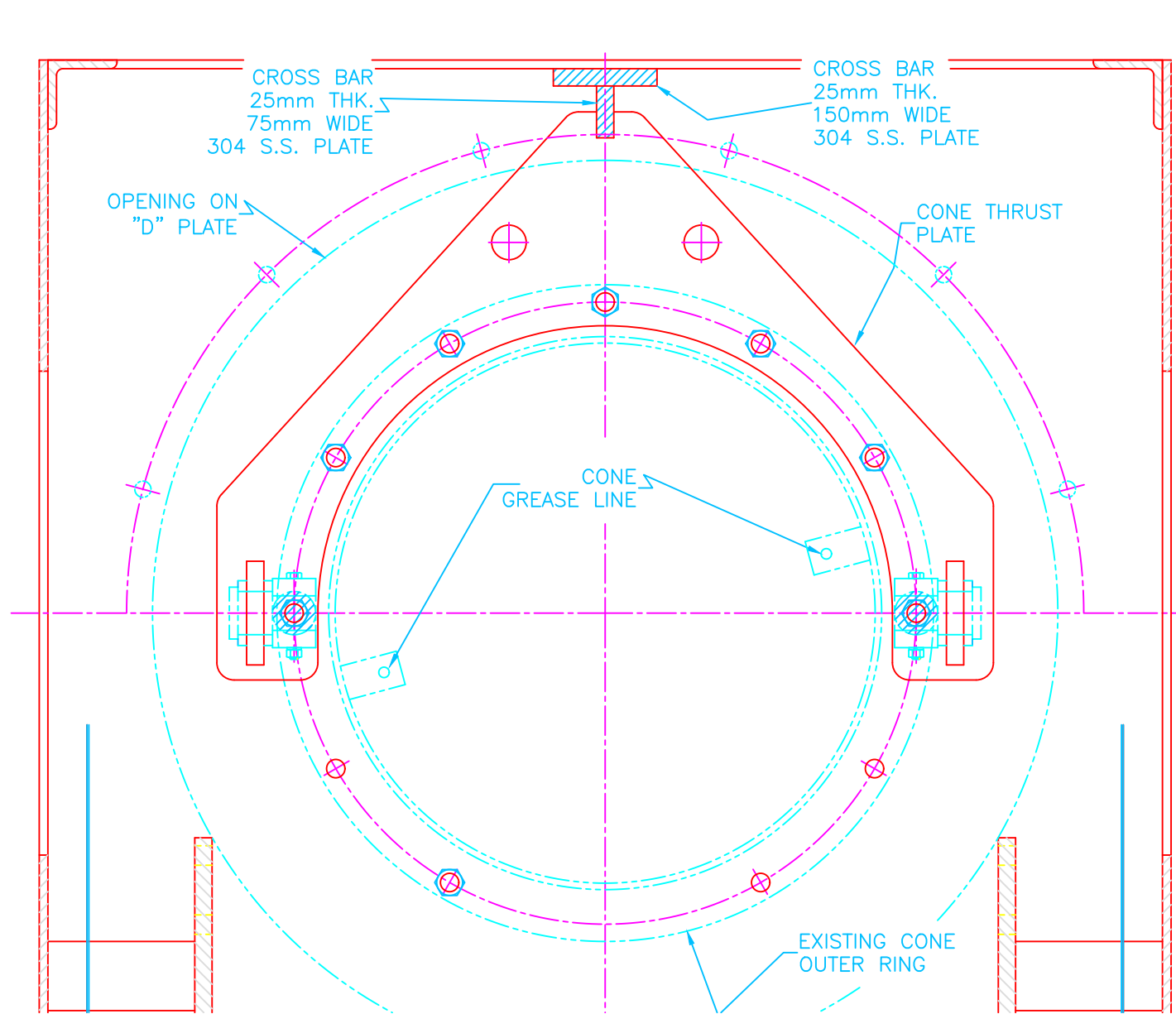

- * M24-3, 4"LG. BOLT WITH NUT AND L/WASHER (7 SETS) REQ'D
- ** M12-1.75, 4.5"LG. BOLT WITH NUT AND L/WASHER (2 SETS) REQ'D

A/C INSTALLATION DETAILS

Vincent CORPORATION		TAMPA, FLORIDA	
VP-30 PRESS CONE MODIFICATION NON ROTATING OPTION			
DRAWN	EG	3/17/2016	SIZE B
COMP. NAME	07037_Master		DRAWING NO. 15220-21
W. O. NO.	15220	SCALE	N.T.S.
		SHEET	

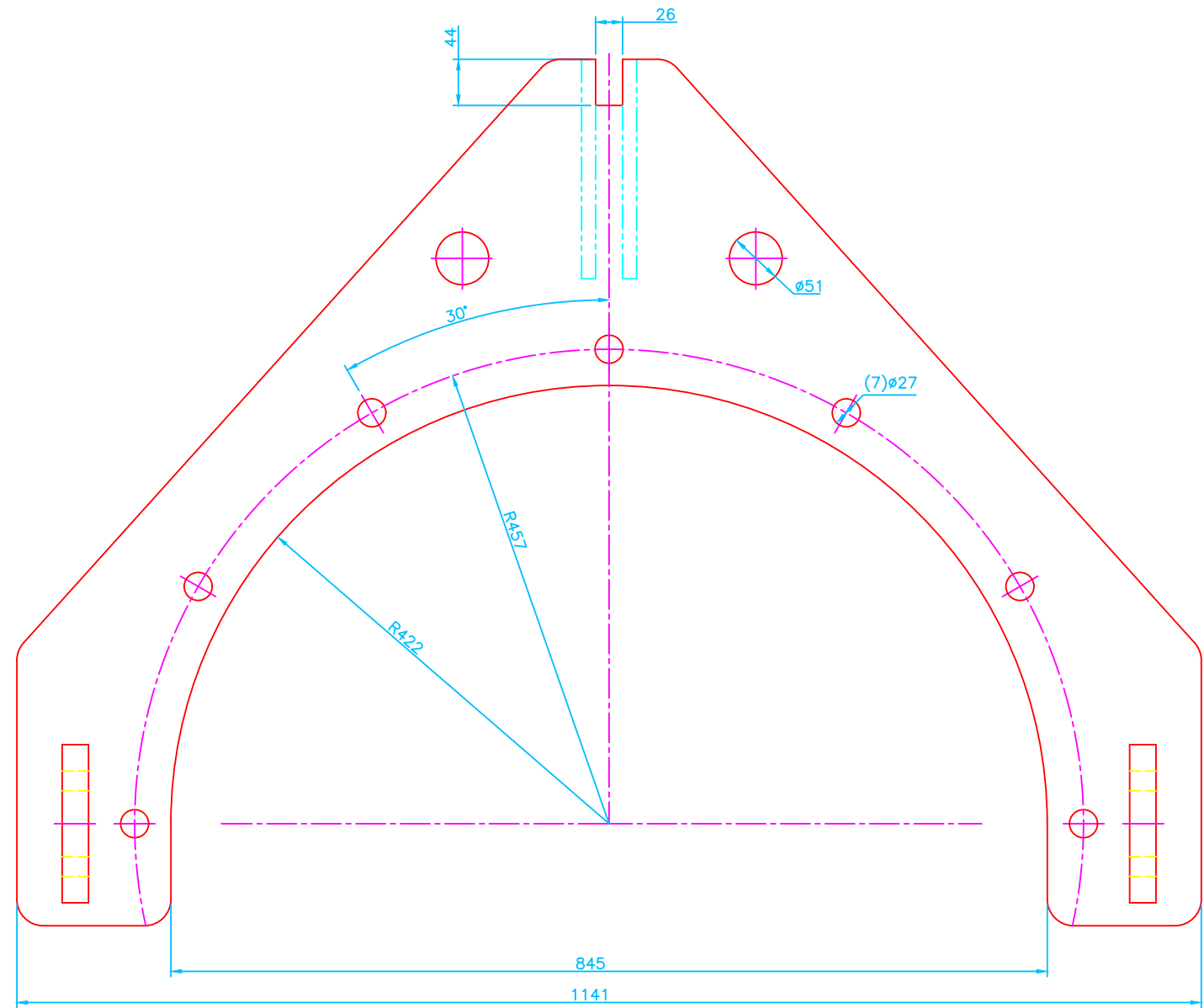

CONE THRUST PLATE ASSEMBLY

MAT'L: 25mmTHK. M.S. PLATE
(1) REQ'D

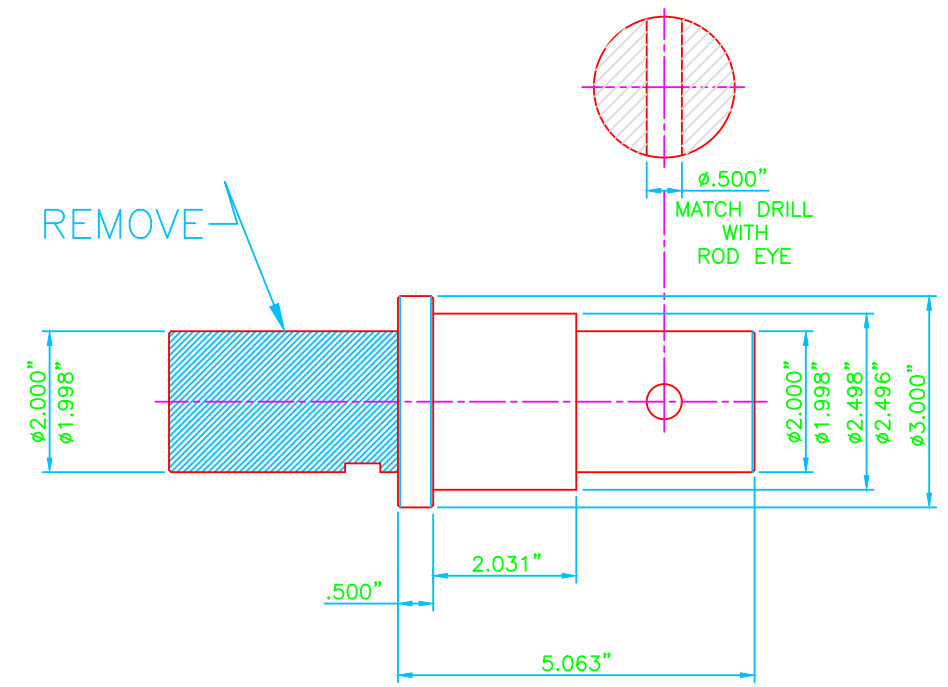
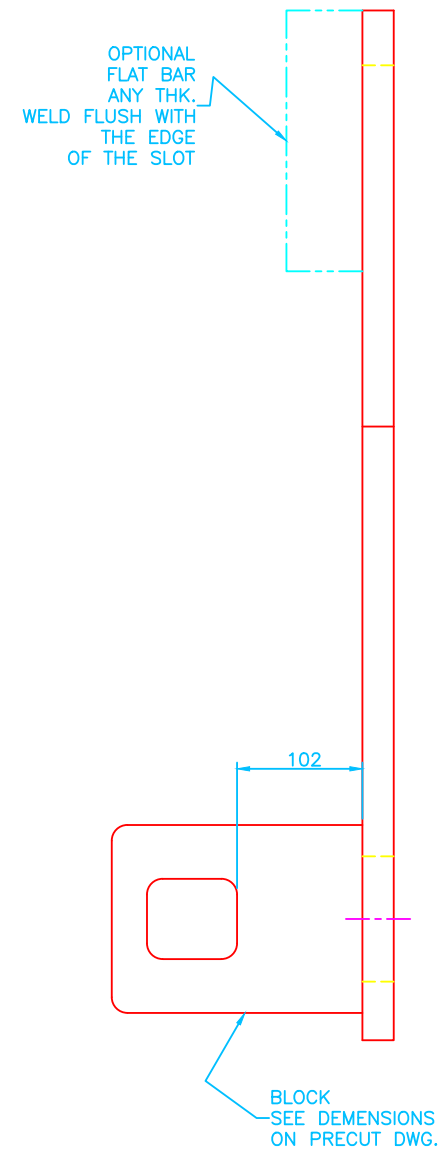

EXISTING AXLE MODIFICATION

N.T.S.
MAT'L: 3"DIA. 304 S.S. ROD
(2) REQ'D

NOTE: 1in. = 25.4mm

Vincent		CORPORATION	
		TAMPA, FLORIDA	
VP-30 PRESS CONE MODIFICATION PARTS DETAILS			
DRAWN	EG	3/17/2016	SIZE
COMP. NAME	07037_Master	B	DRAWING NO.
W. O. NO.	15220	SCALE	N.T.S.
			SHEET
			15220-21

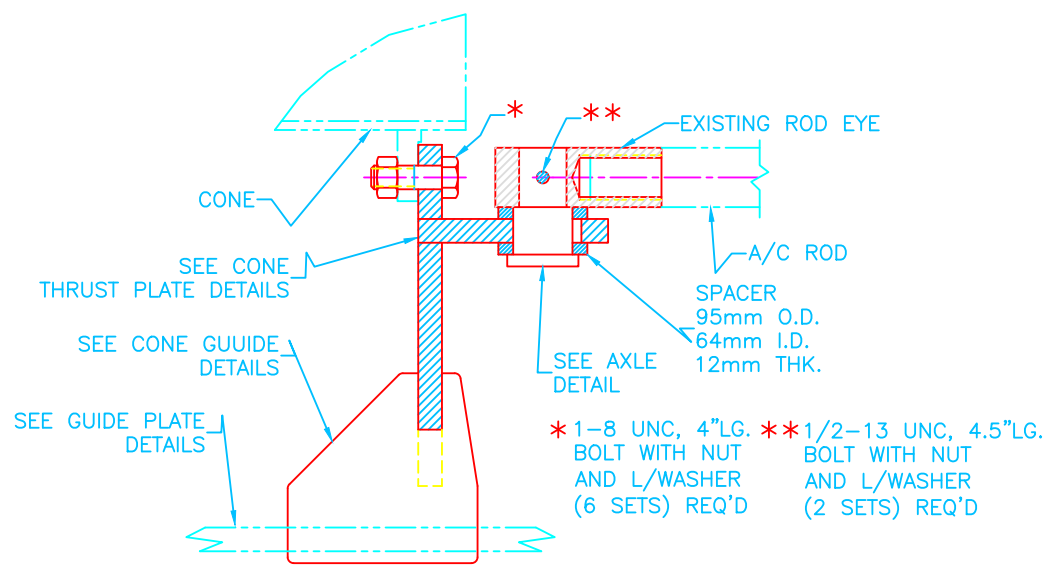
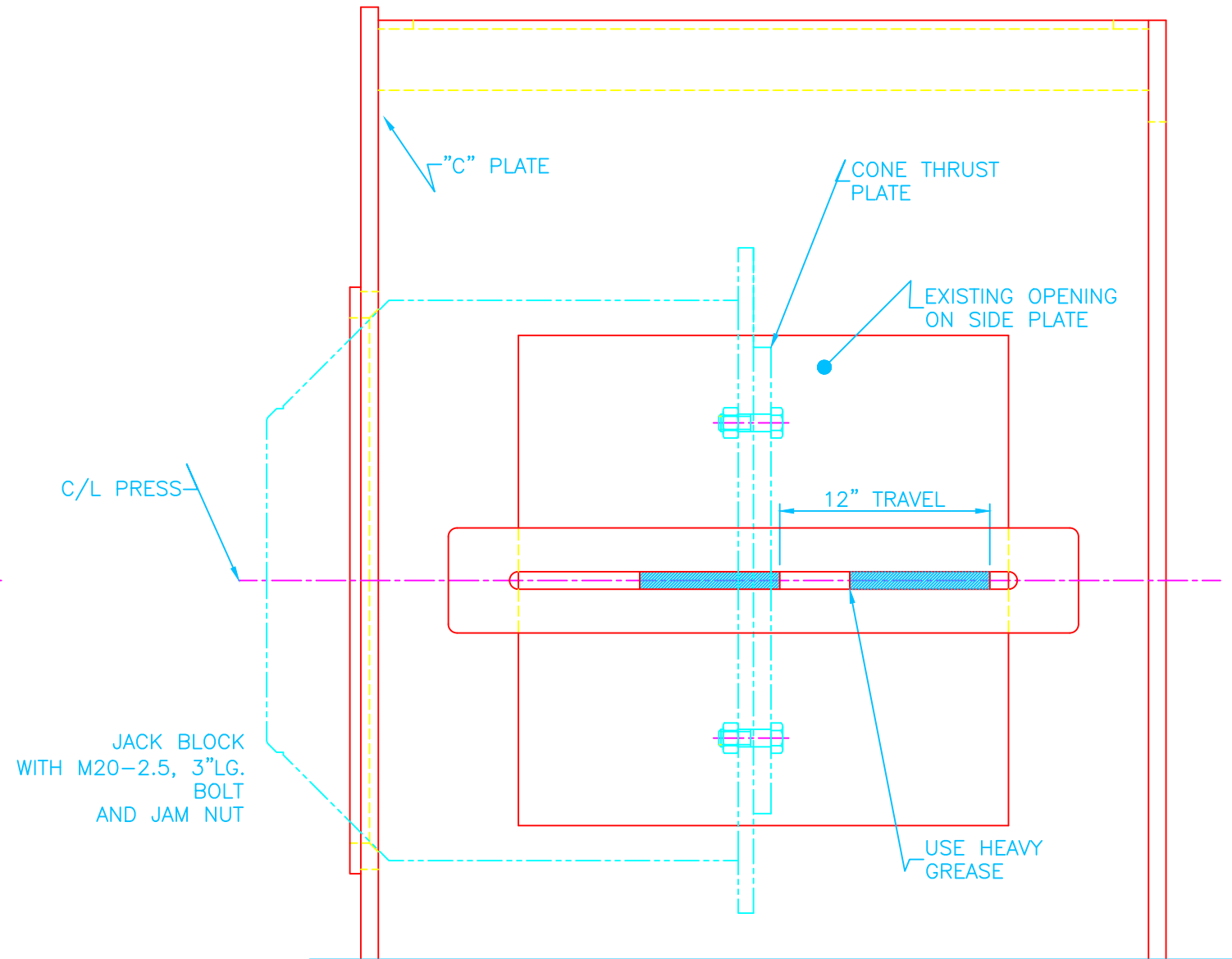
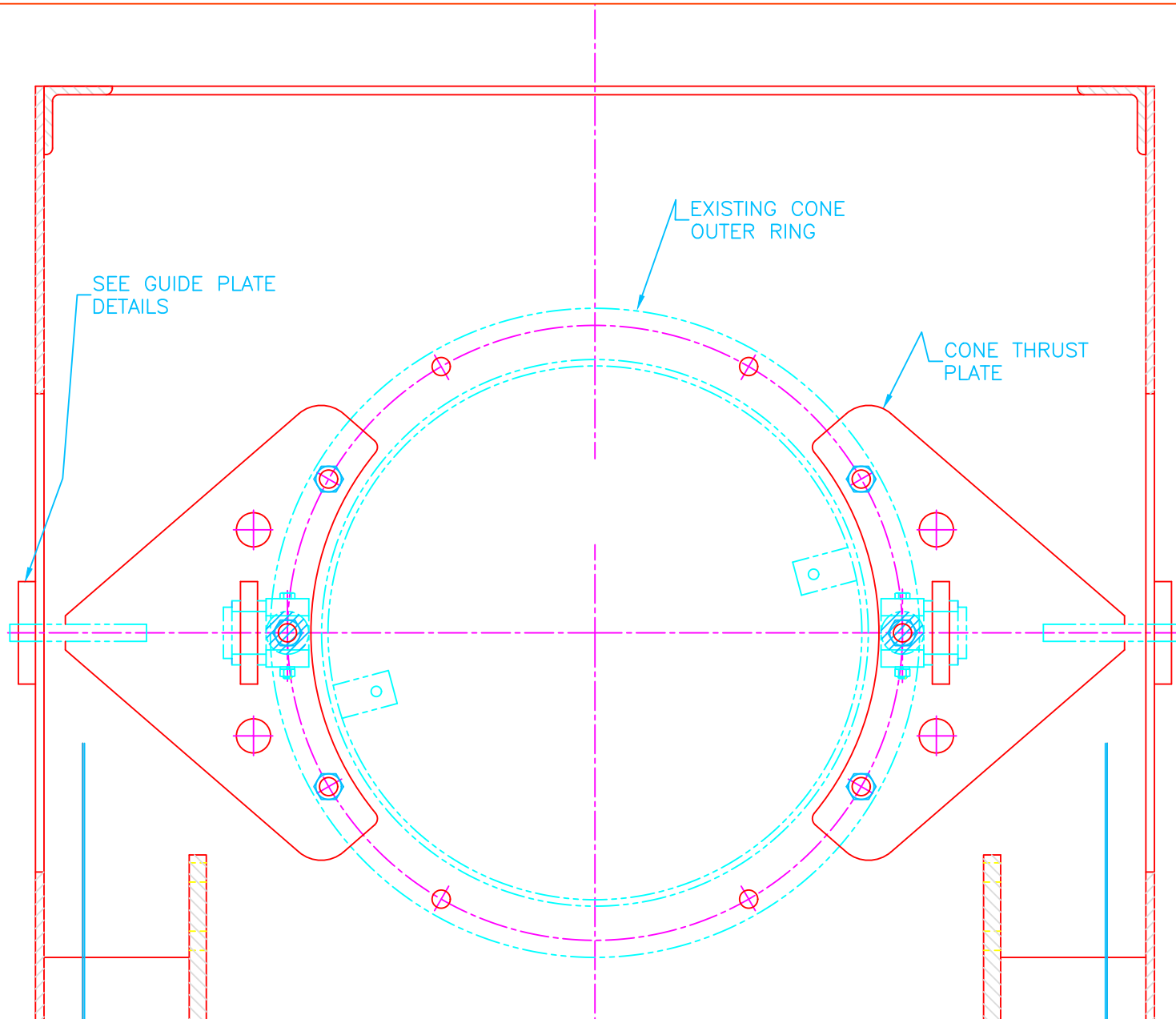

A/C INSTALLATION DETAILS

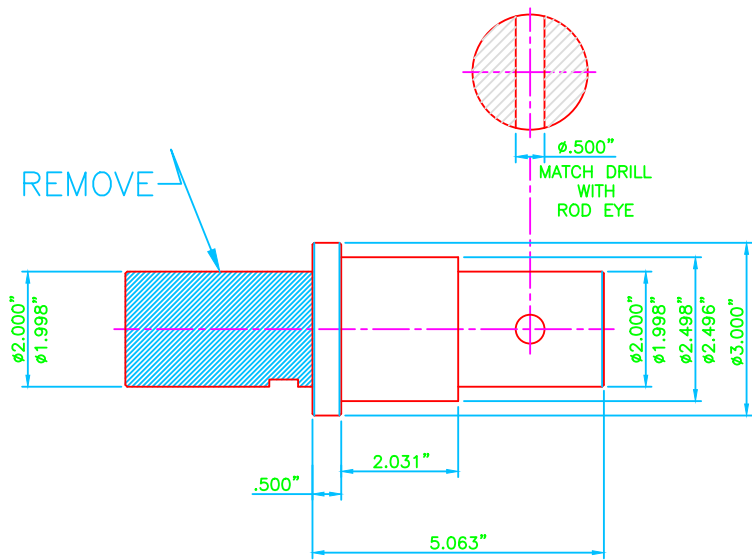

EXISTING AXLE MODIFICATION

Vincent CORPORATION
TAMPA, FLORIDA

VP-30 PRESS
CONE MODIFICATION
NON ROTATING OPTION

DRAWN	EG	3/17/2016	SIZE	DRAWING NO.
COMP. NAME	07037_Master		B	15220-23
W. O. NO.	15220	SCALE	N. T. S.	SHEET

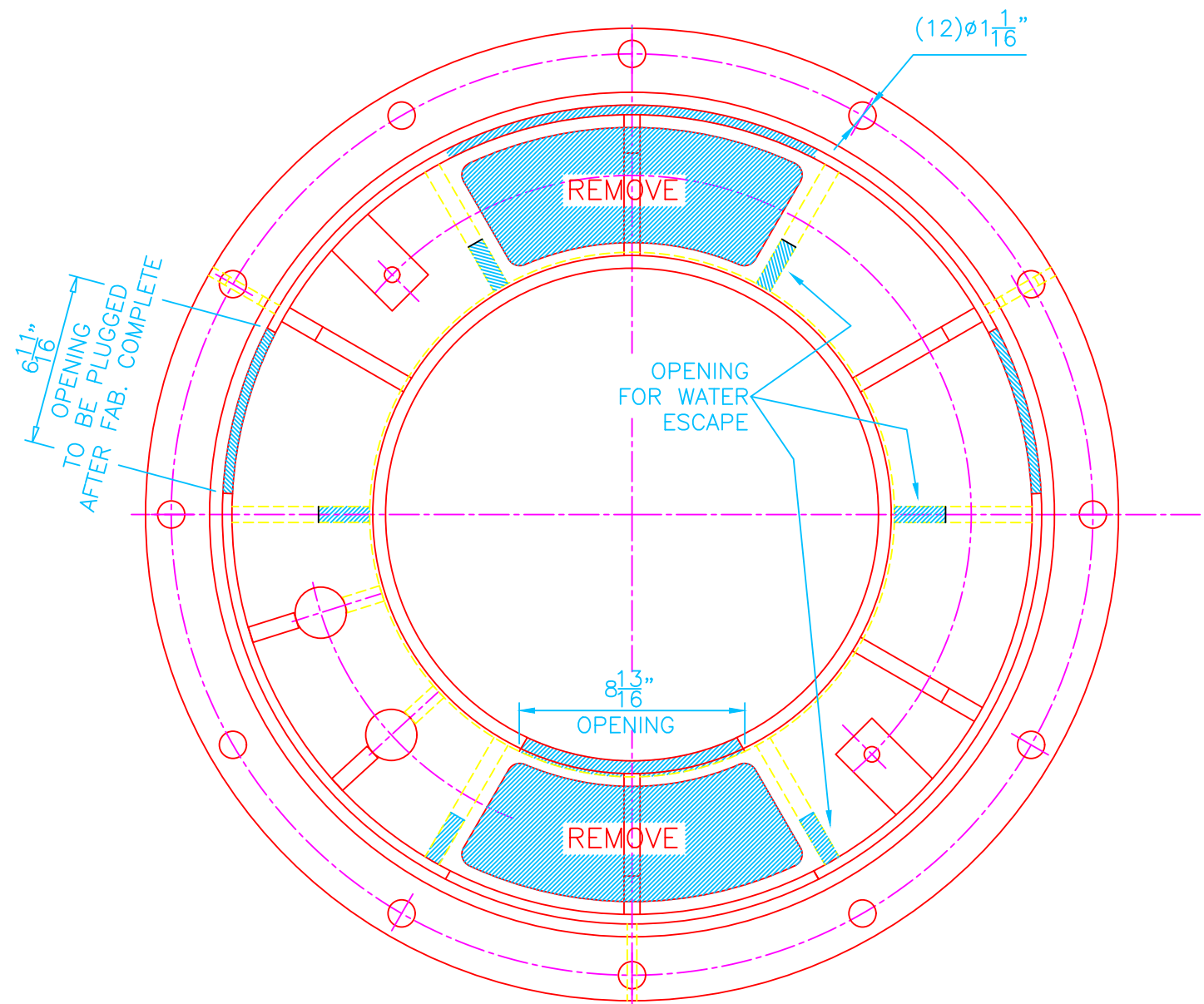
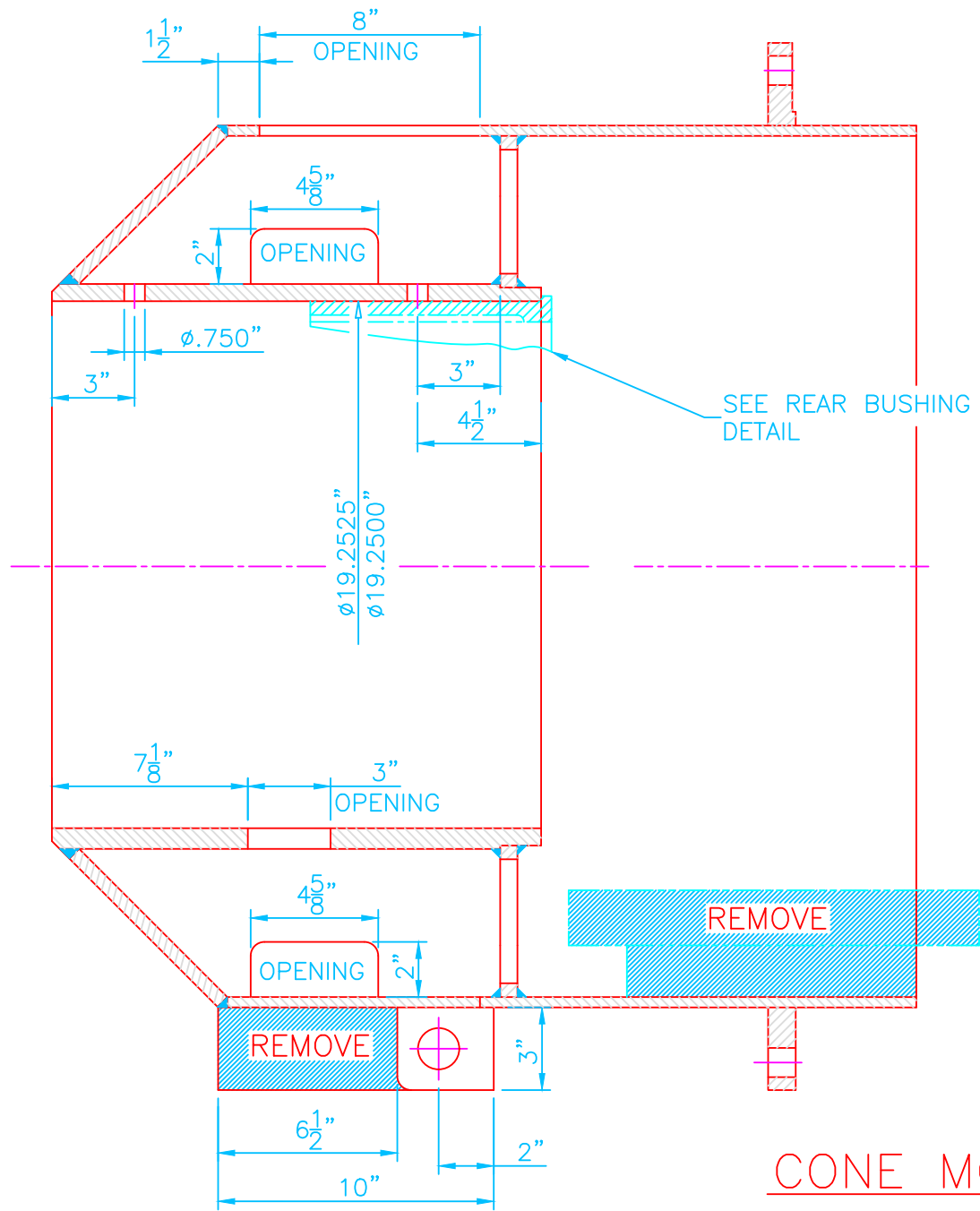

CONE MODIFICATION STEP-1

SEE TRUE LOCATION OF MODIFICATIONS
ON SIDE VIEW

Vincent CORPORATION
TAMPA, FLORIDA

VP-30 PRESS
CONE MODIFICATION
NON ROTATING OPTION

DRAWN	EG	3/29/2016	SIZE	DRAWING NO.
COMP. NAME	07037_Master		B	15220-25
W. O. NO.	15220	SCALE	N. T. S.	SHEET

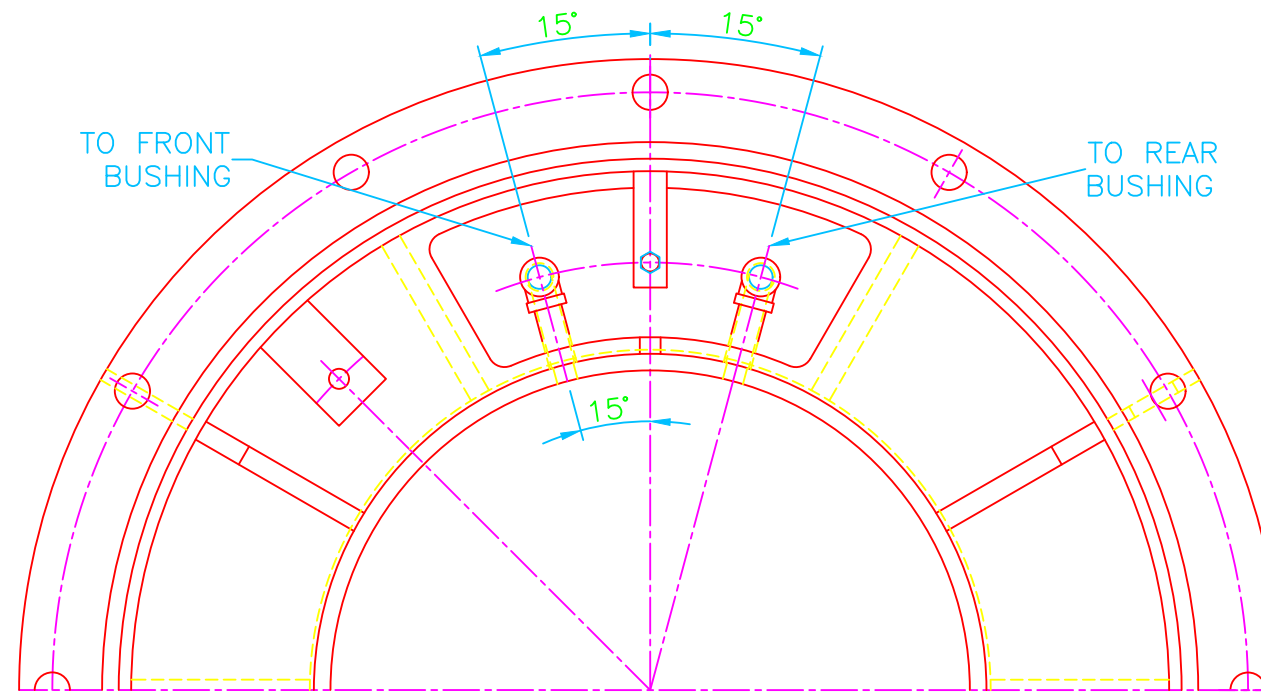
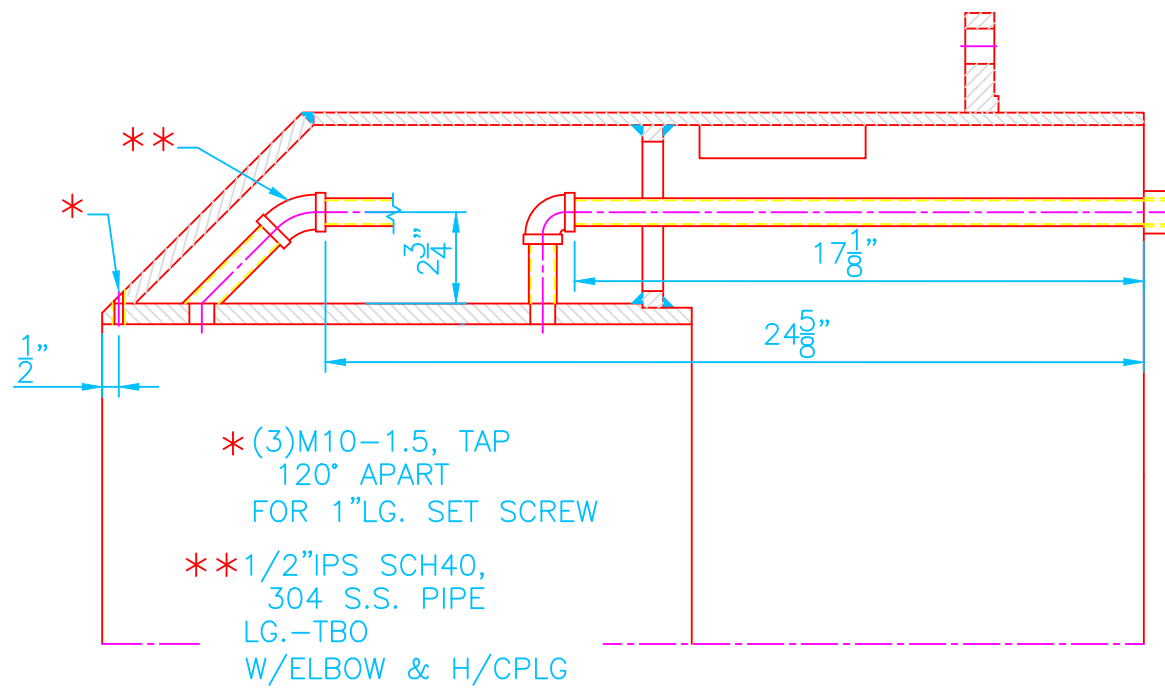

CONE MODIFICATION STEP-2

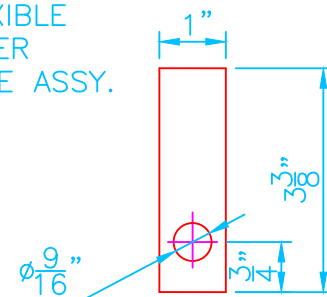
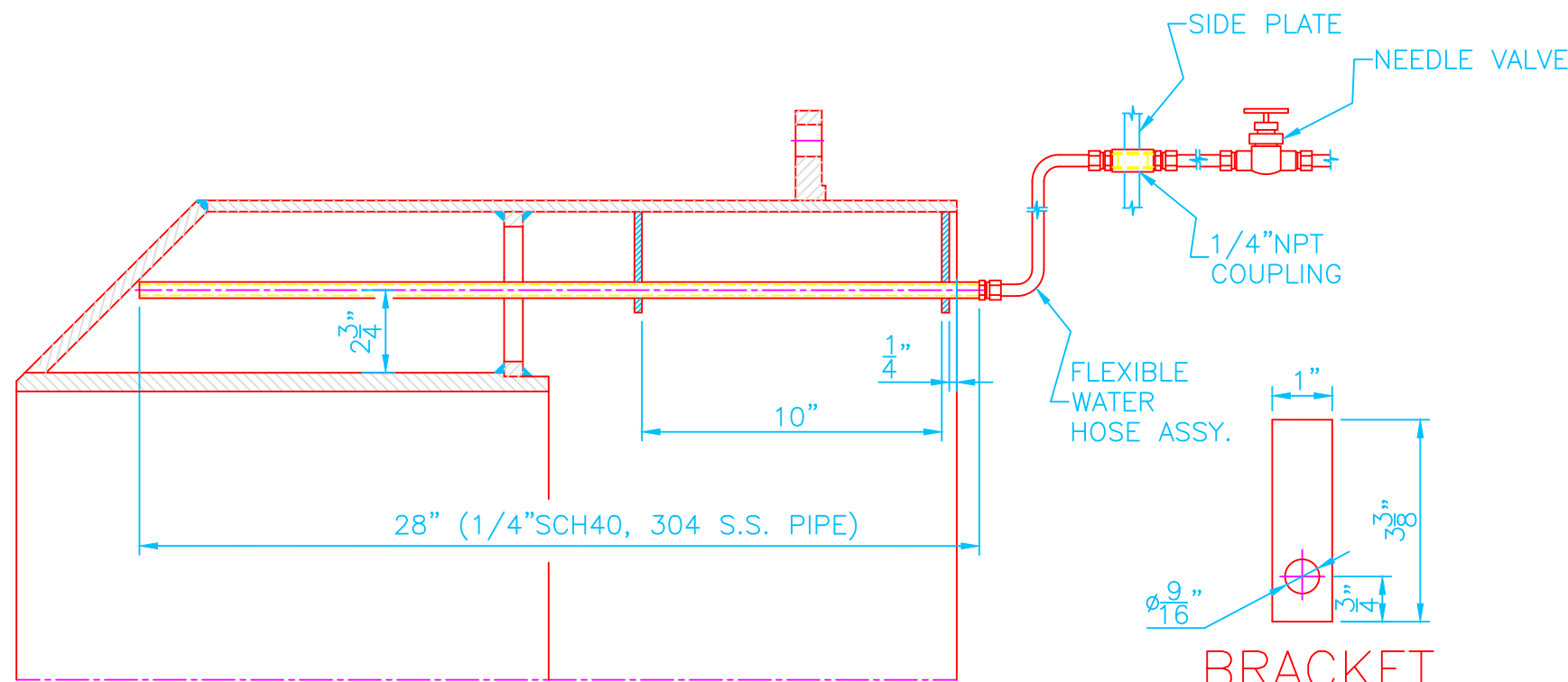

BRACKET

MAT'L: 1/4 X 1, 304 S.S. F.B.
 (1) REQ'D

WATER LINE INSTALLATION DIAGRAM

Vincent CORPORATION
 TAMPA, FLORIDA

VP-30 PRESS
 CONE MODIFICATION
 NON ROTATING OPTION

DRAWN	EG	3/29/2016	SIZE	DRAWING NO.
COMP. NAME	07037_Master		B	15220-26
W. O. NO.	15220	SCALE	N. T. S.	SHEET

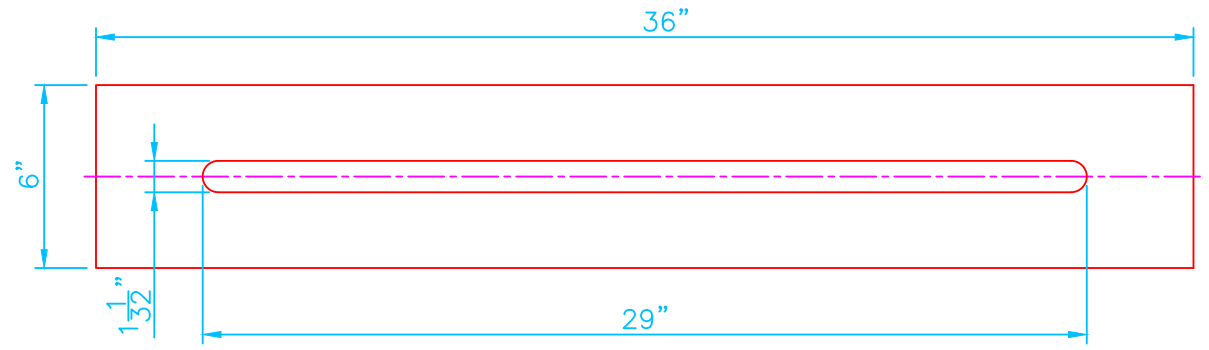
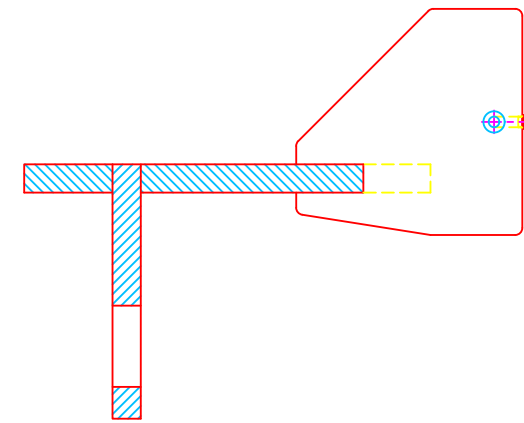
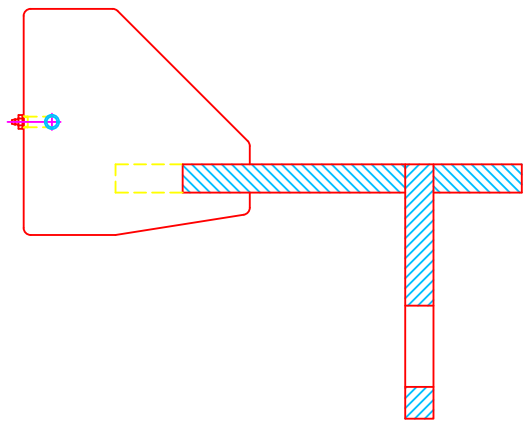

RAIL

MAT'L: 1"THK. 304 S.S. PLATE
(2) REQ'D

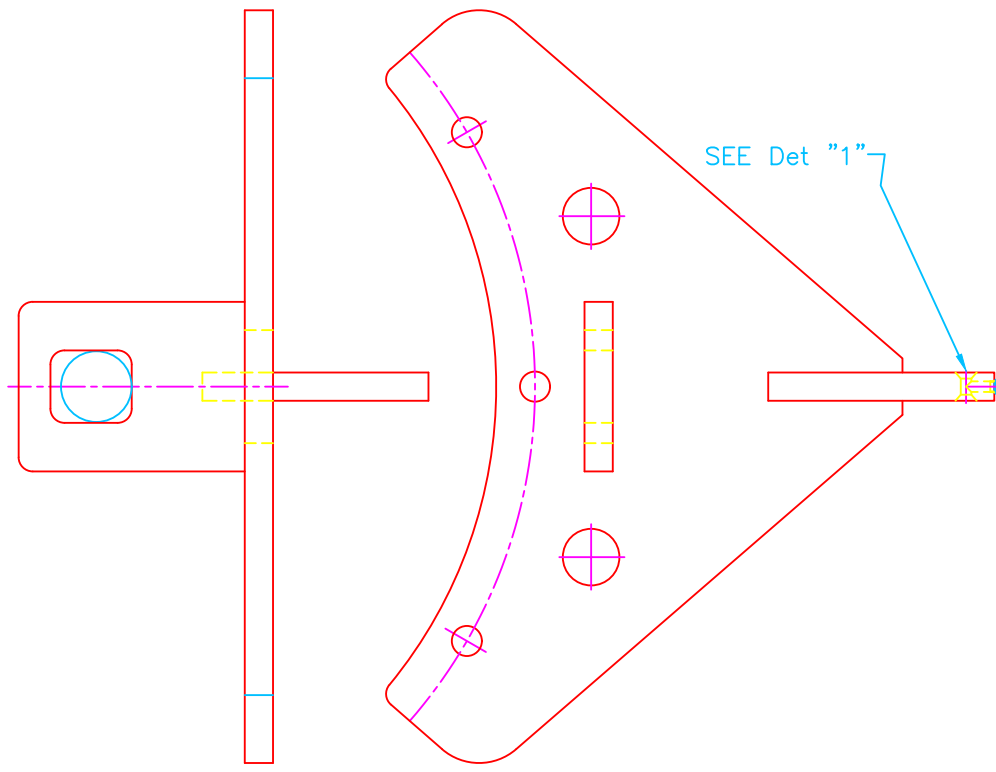
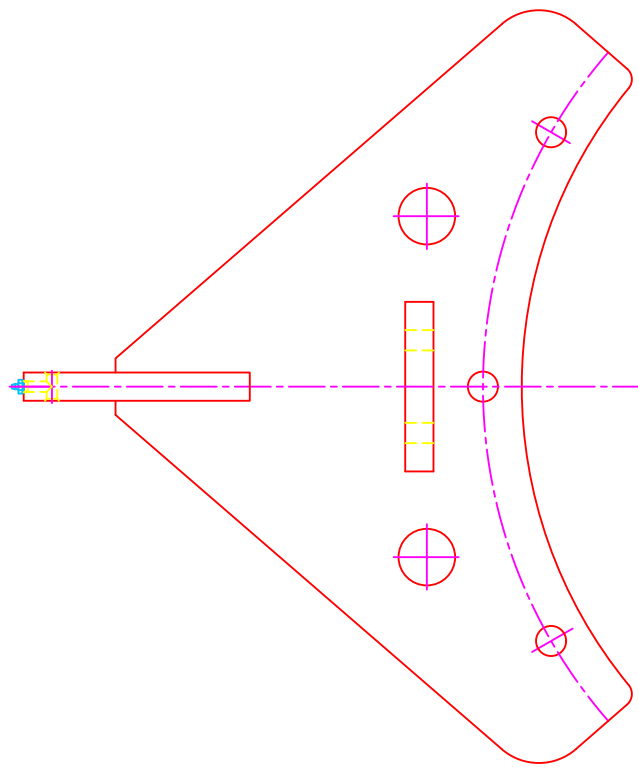

GUIDE PLATE

MAT'L: 1/2"THK. 304 S.S. PLATE
(2) REQ'D

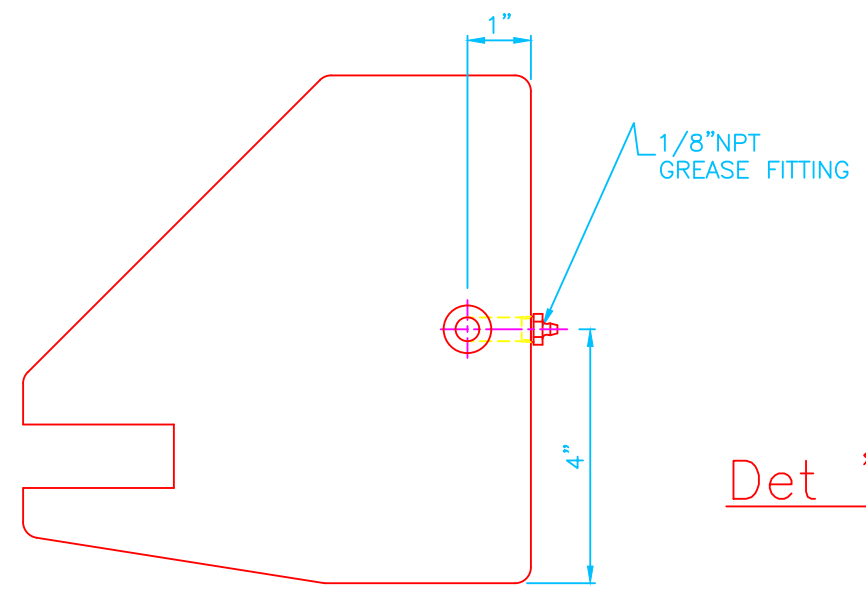

Det "1"

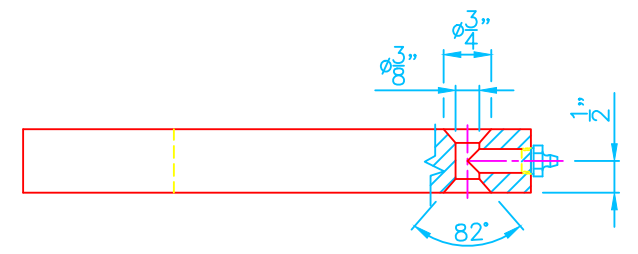

Vincent		CORPORATION	
		TAMPA, FLORIDA	
VP-30 PRESS CONE MODIFICATION PARTS DETAILS			
DRAWN	EG	5/24/2016	SIZE
COMP. NAME	07037_Master		B
DRAWING NO.		15220-27A	
W. O. NO.	15220	SCALE	N. T. S.
		SHEET	

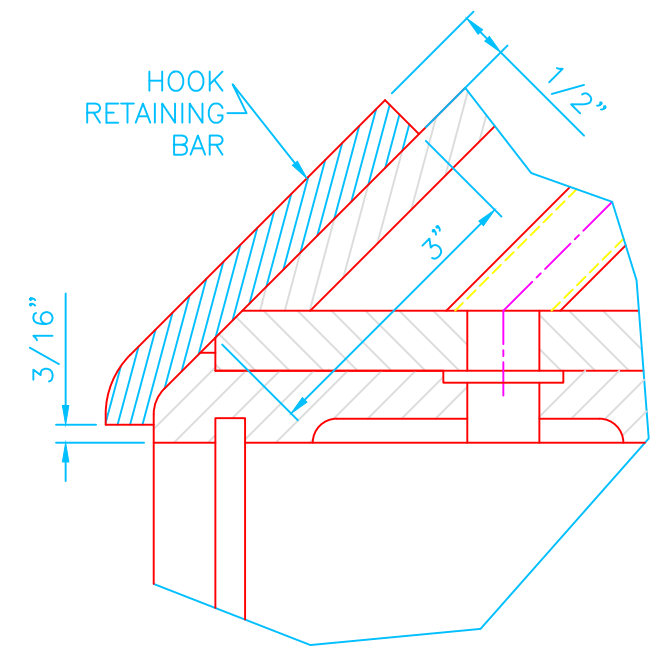
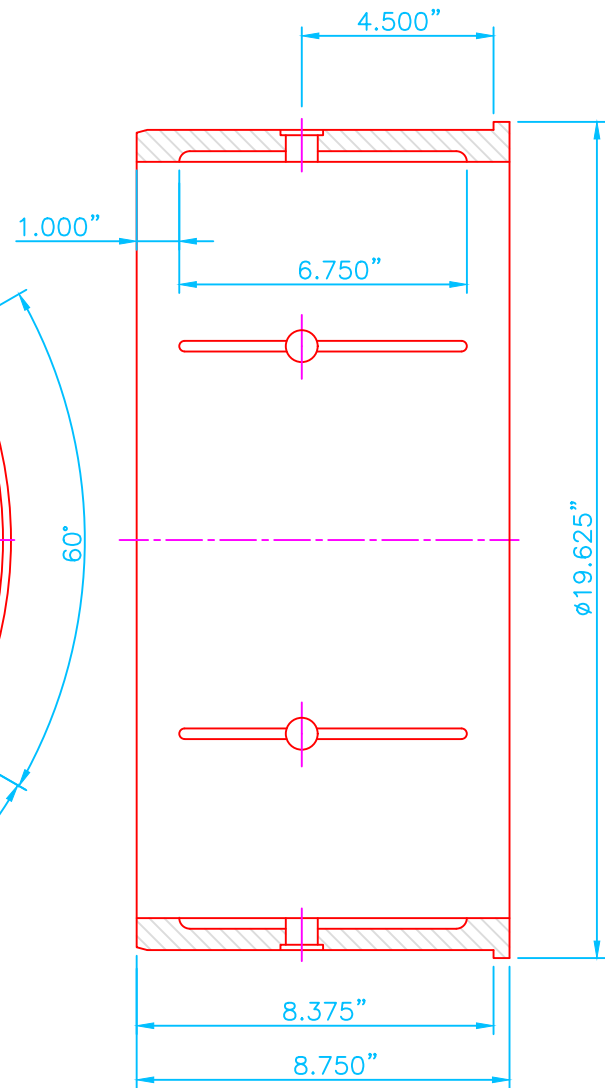
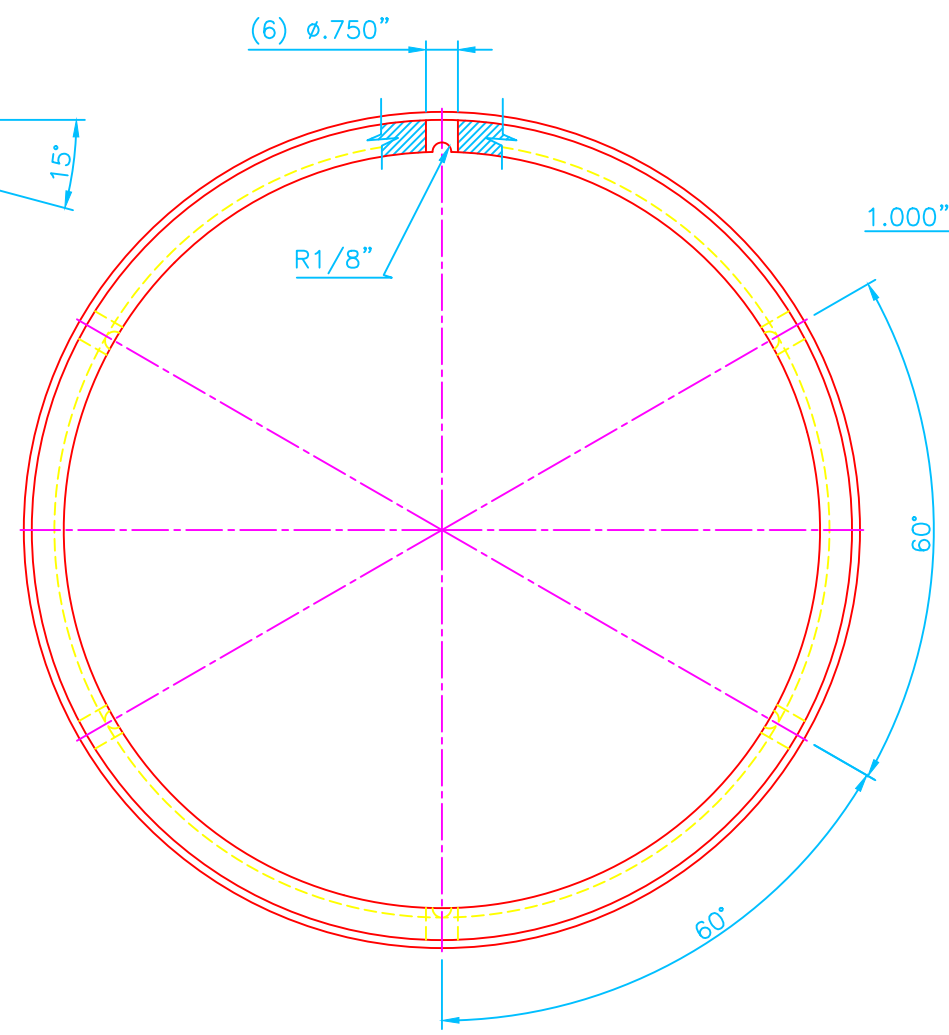
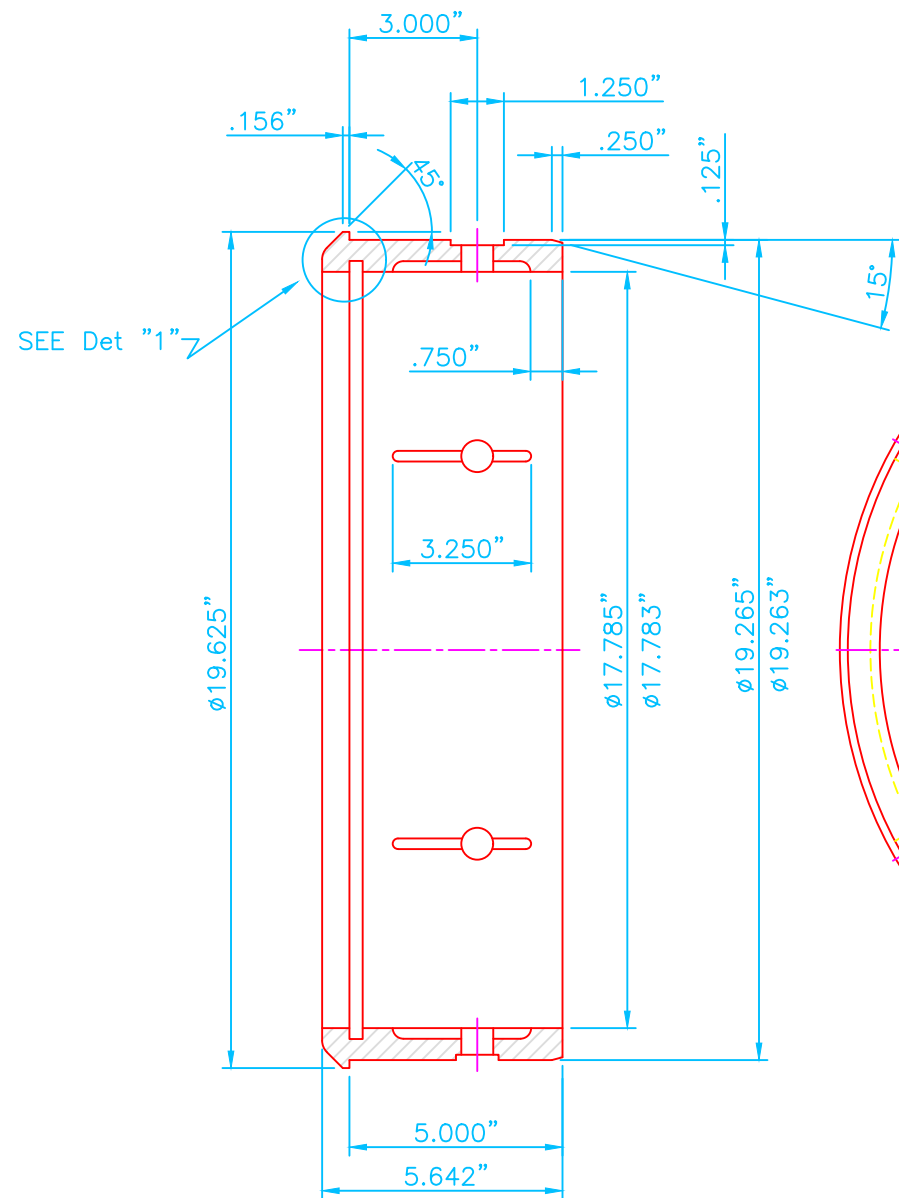

HOOK RETAINING BAR
 INSTALLATION DIAGRAM
 MAT'L: 1/2"THK. 304 S.S. PLATE

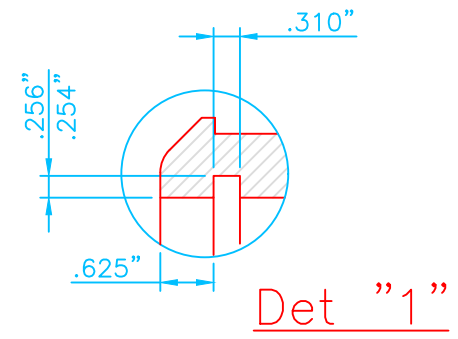

FRONT AND REAR BUSHINGS
 MAT'L: 660 BRONZE
 USE .275"QUAD O-RING, MAT'L: NEOPRENE

Vincent CORPORATION		TAMPA, FLORIDA	
VP-30 PRESS FRONT & REAR CONE BUSHINGS AND HOOK RETAINING BAR			
DRAWN	EG	8/12/2016	SIZE
COMP. NAME	07037_Master	B	DRAWING NO.
W. O. NO.	15220	SCALE	N. T. S.
		SHEET	
		15220-31	

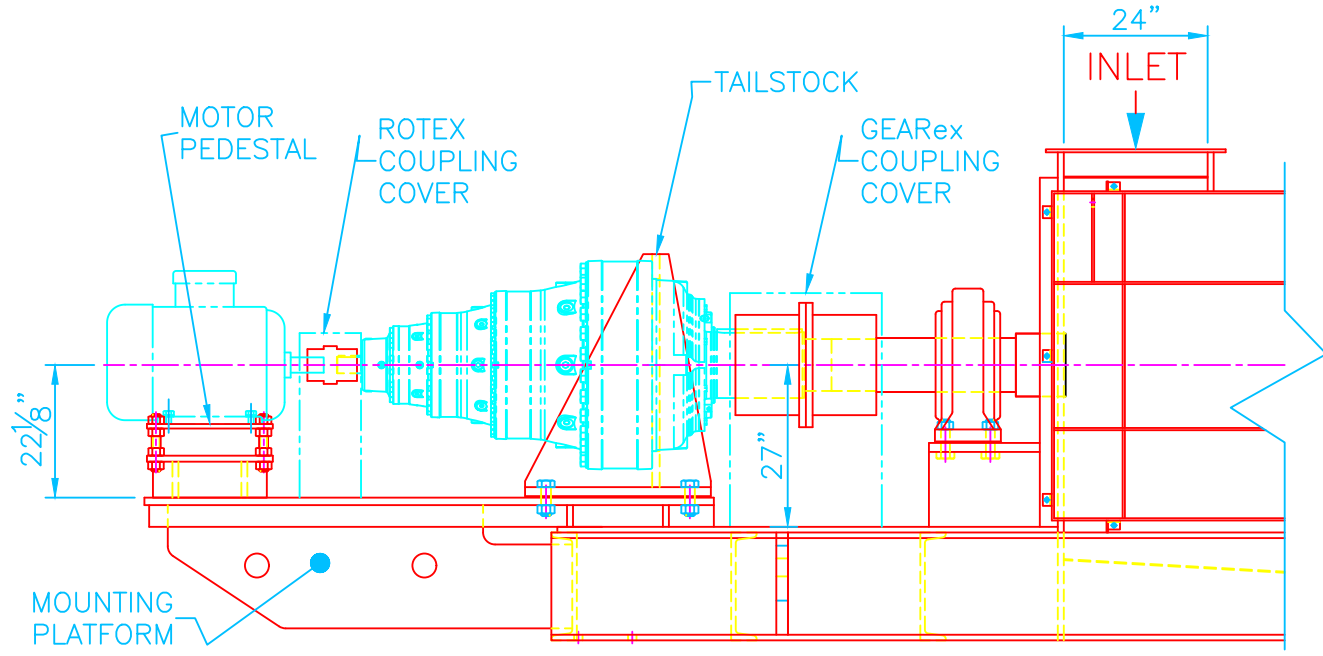
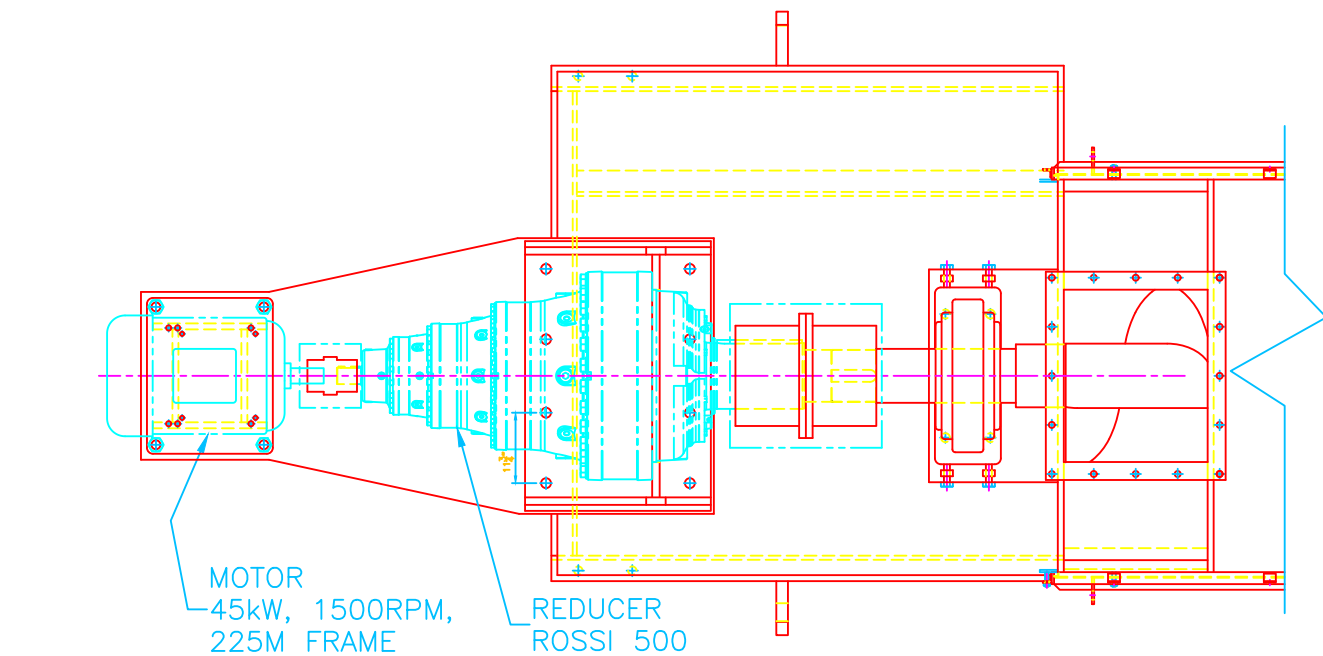

REDUCER INSTALLATION DIAGRAM

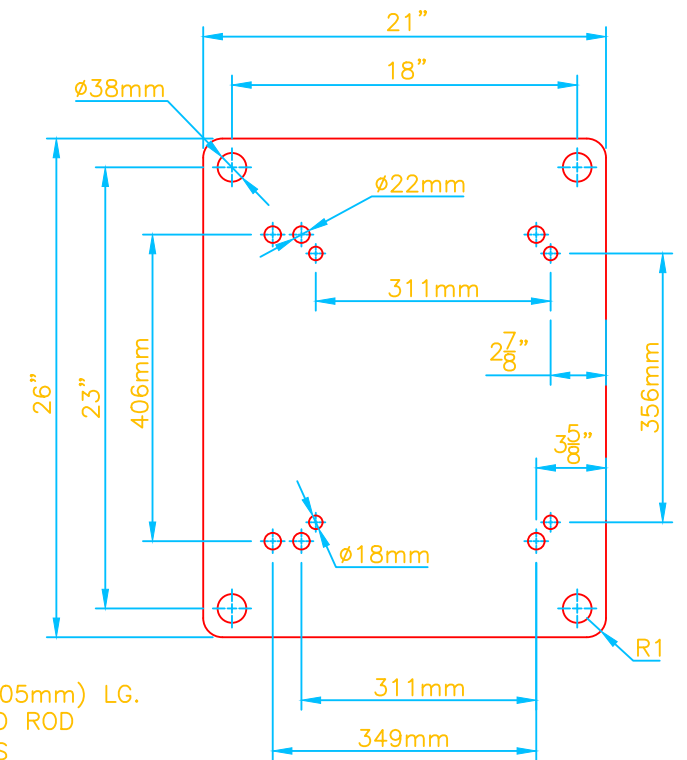
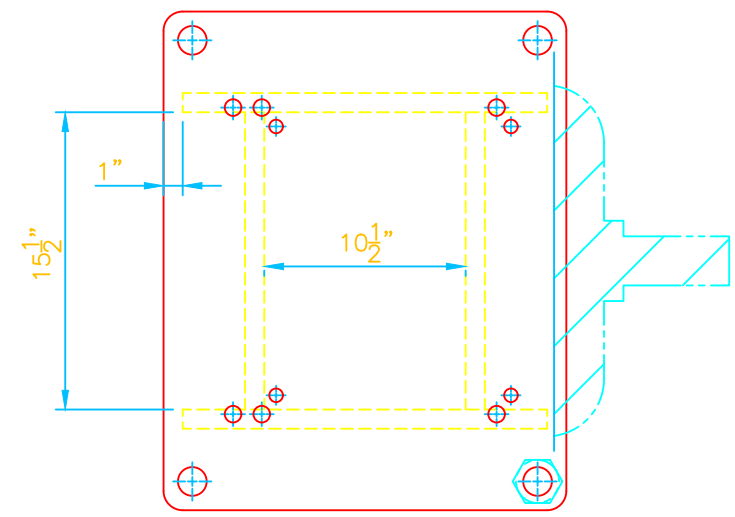

MOTOR PLATE

MAT'L: 3/4"(19mm)THK. M.S. PLATE

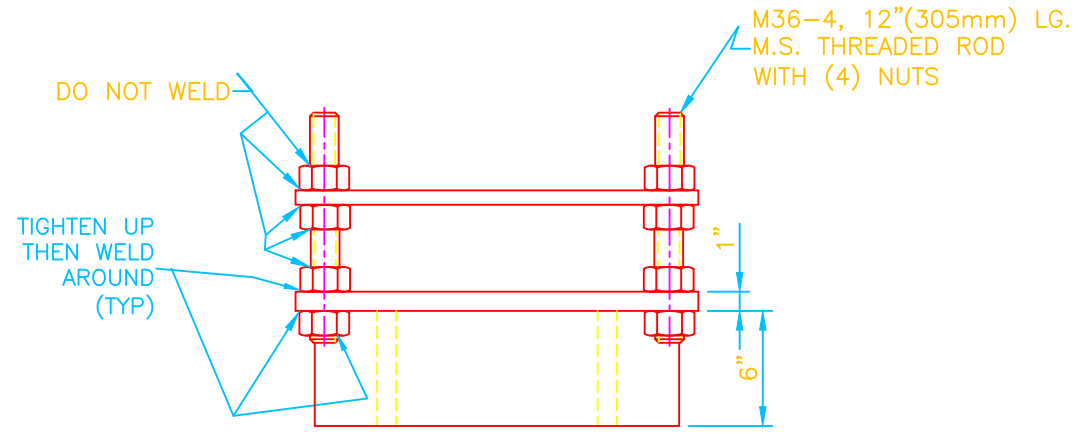

MOTOR PEDESTAL

MAT'L: 1"THK. M.S. PLATE

Vincent CORPORATION
TAMPA, FLORIDA

VP-30 PRESS
REDUCER INSTALLATION DIAGRAM
ROSSI-500A

DRAWN	EG	8/12/2016	SIZE	DRAWING NO.
COMP. NAME	07037_Master		B	15220-33
W. O. NO.	15220	SCALE	N. T. S.	SHEET

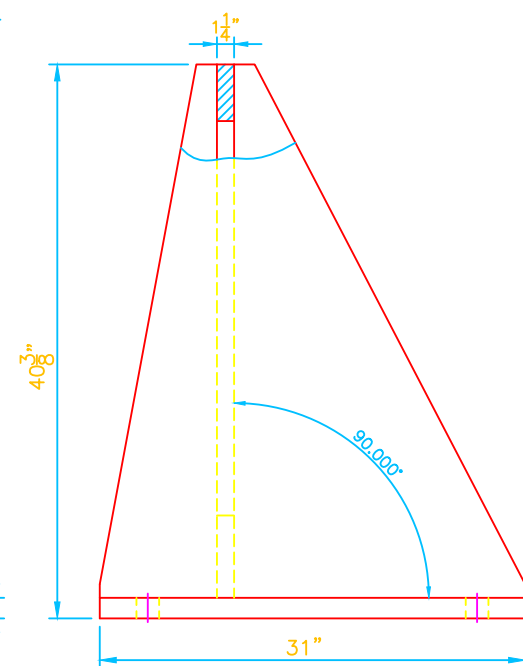
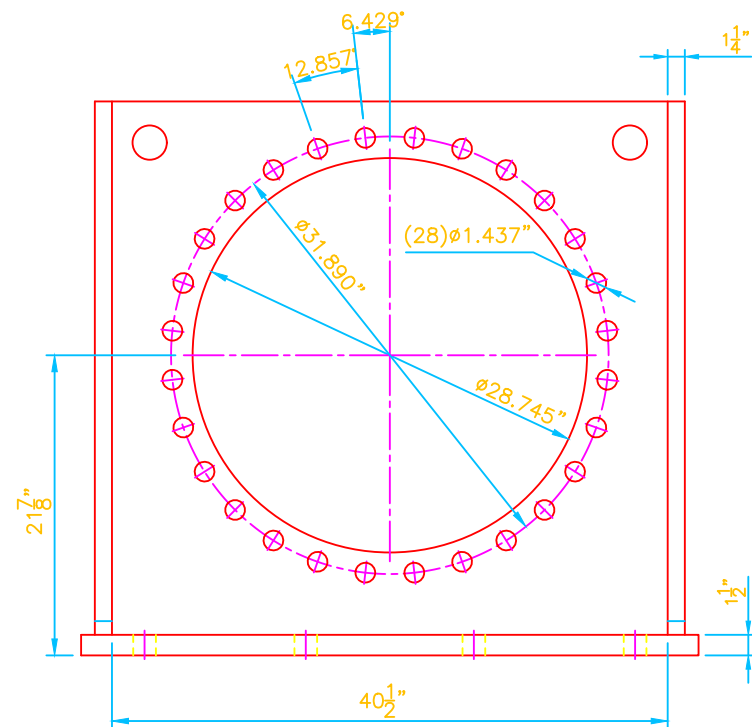
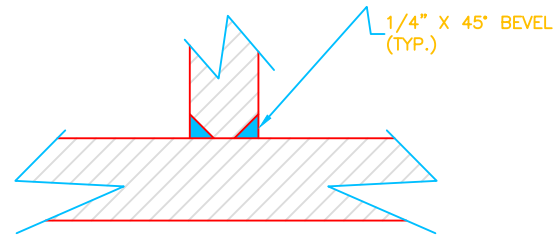
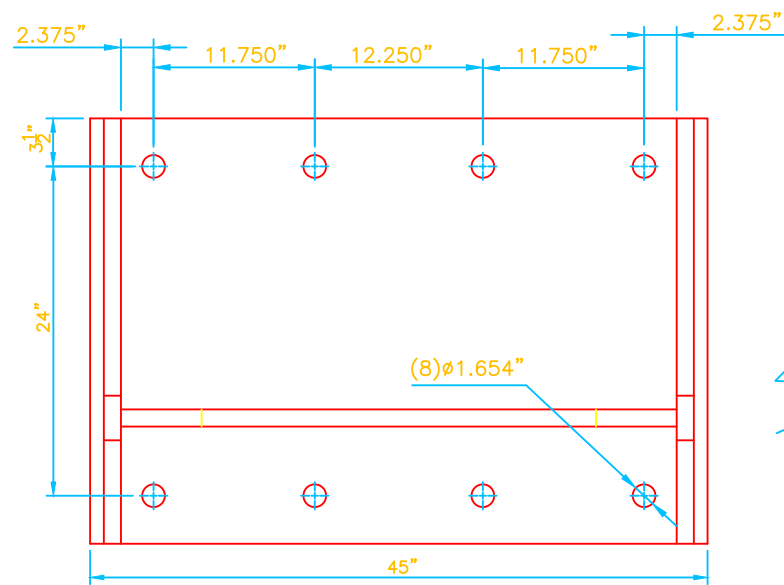

ROSSI REDUCER TAILSTOCK
MAT'L: M.S. PLATE

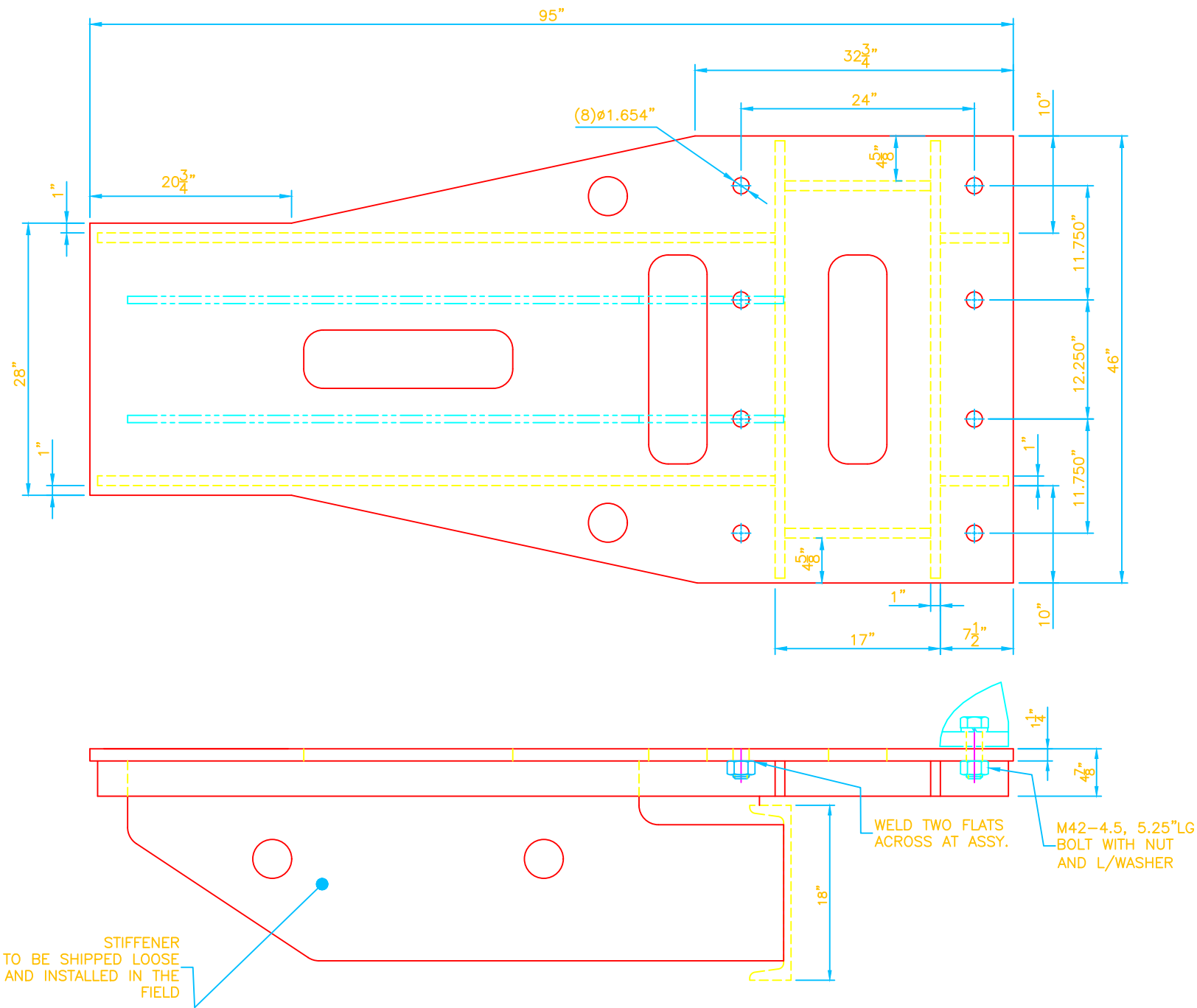

STIFFENER
TO BE SHIPPED LOOSE
AND INSTALLED IN THE
FIELD

WELD TWO FLATS
ACROSS AT ASSY.
M42-4.5, 5.25"LG
BOLT WITH NUT
AND L/WASHER

MOUNTING PLATFORM ASSEMBLY
MAT'L: M.S. PLATE

Vincent CORPORATION		TAMPA, FLORIDA	
VP-30 PRESS ROSSI REDUCER TAILSTOCK AND MOUNTING PLATFORM ASSEMBLY			
DRAWN	EG	8/12/2016	SIZE
COMP. NAME	07037_Master	B	DRAWING NO.
W. O. NO.	15220	SCALE	N. T. S.
		SHEET	

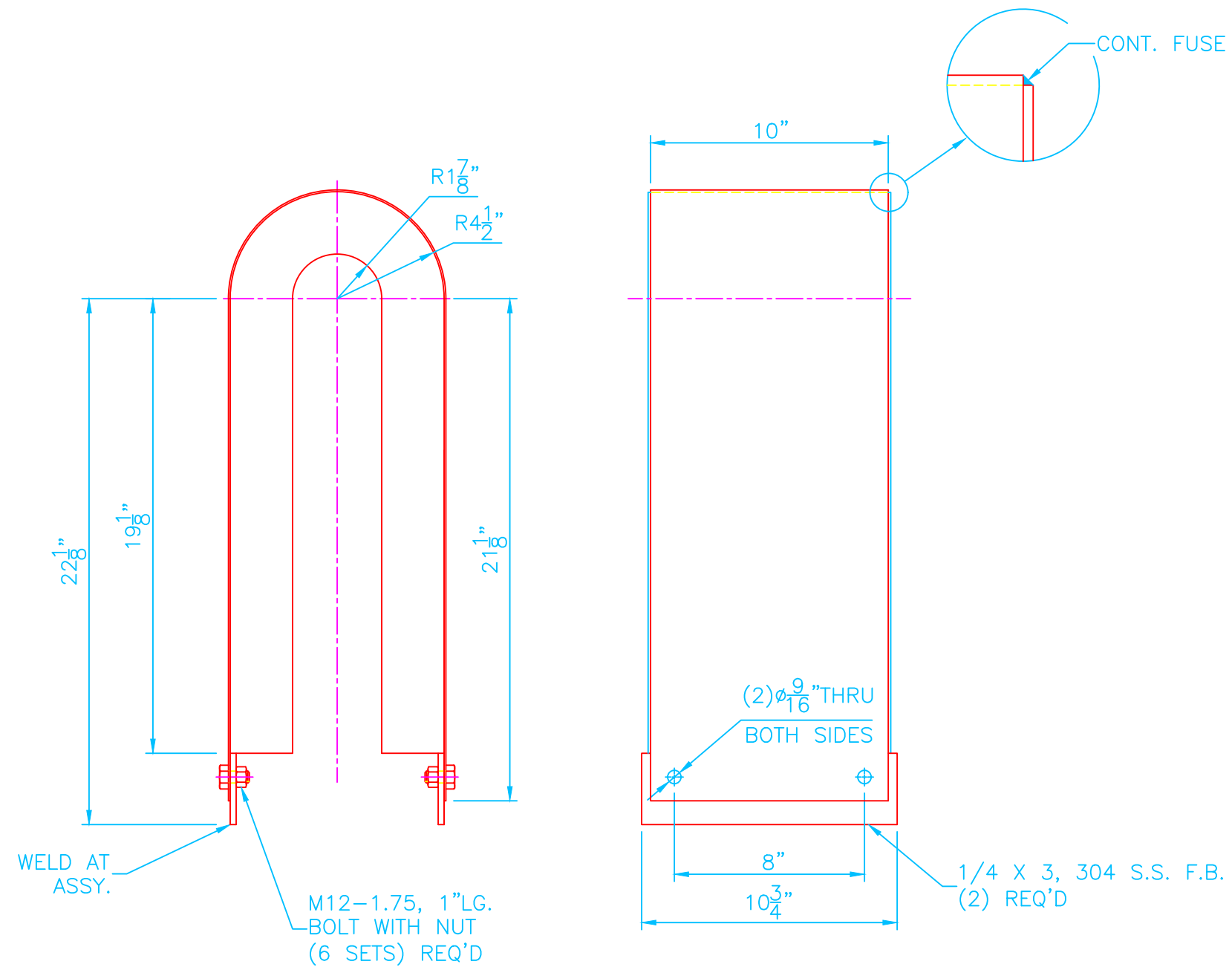

ROTEX COUPLING COVER

MAT'L: 14GA. 304 S.S. SHEET

Vincent CORPORATION
TAMPA, FLORIDA

VP-30 PRESS
ROTEX COUPLING COVER
DETAILS

DRAWN	EG	8/12/2016	SIZE	DRAWING NO.
COMP. NAME	07037_Master		B	15220-35
W. O. NO.	15220	SCALE	N. T. S.	SHEET

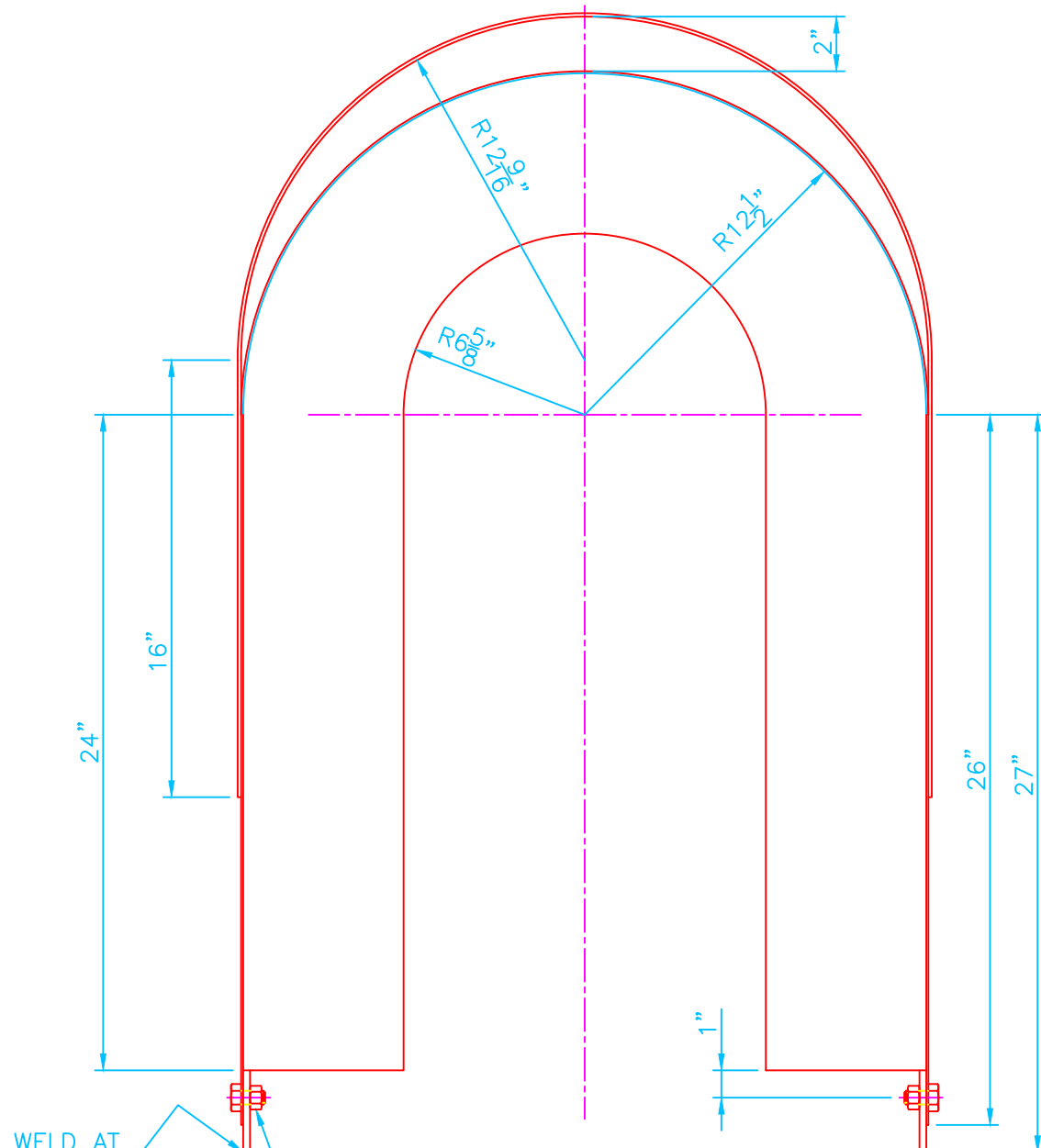

WELD AT ASSY.

M12-1.75, 1" LG. BOLT WITH NUT (6 SETS) REQ'D

1/4 X 3, 304 S.S. F.B. (2) REQ'D

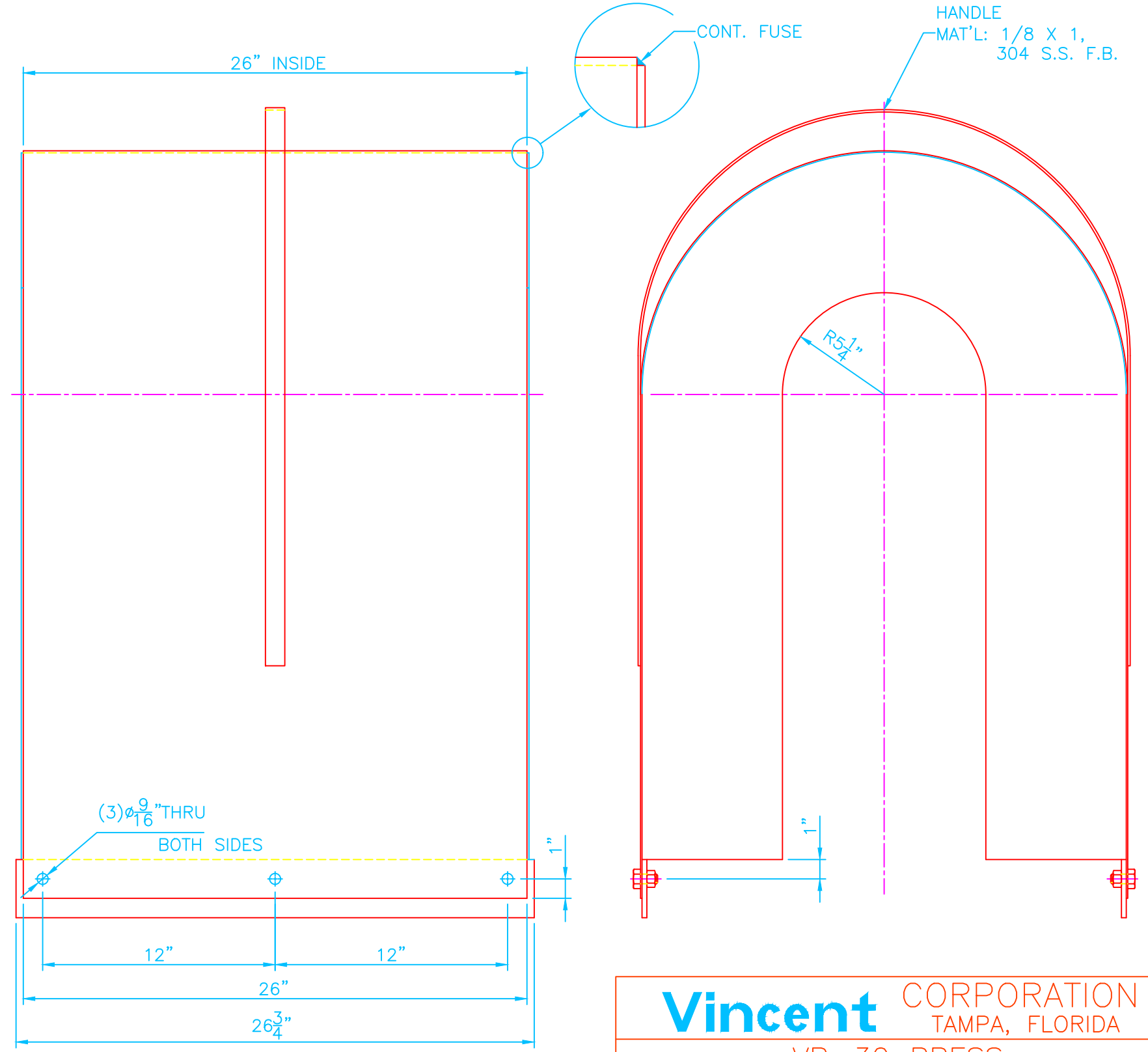

GEARex COUPLING COVER
 MAT'L: 14GA. 304 S.S. SHEET

Vincent CORPORATION
 TAMPA, FLORIDA

VP-30 PRESS
 GEARex COUPLING COVER
 DETAILS

DRAWN EG	8/12/2016	SIZE B	DRAWING NO. 15220-36
COMP. NAME 07037_Master			
W. O. NO. 15220	SCALE N.T.S.	SHEET	

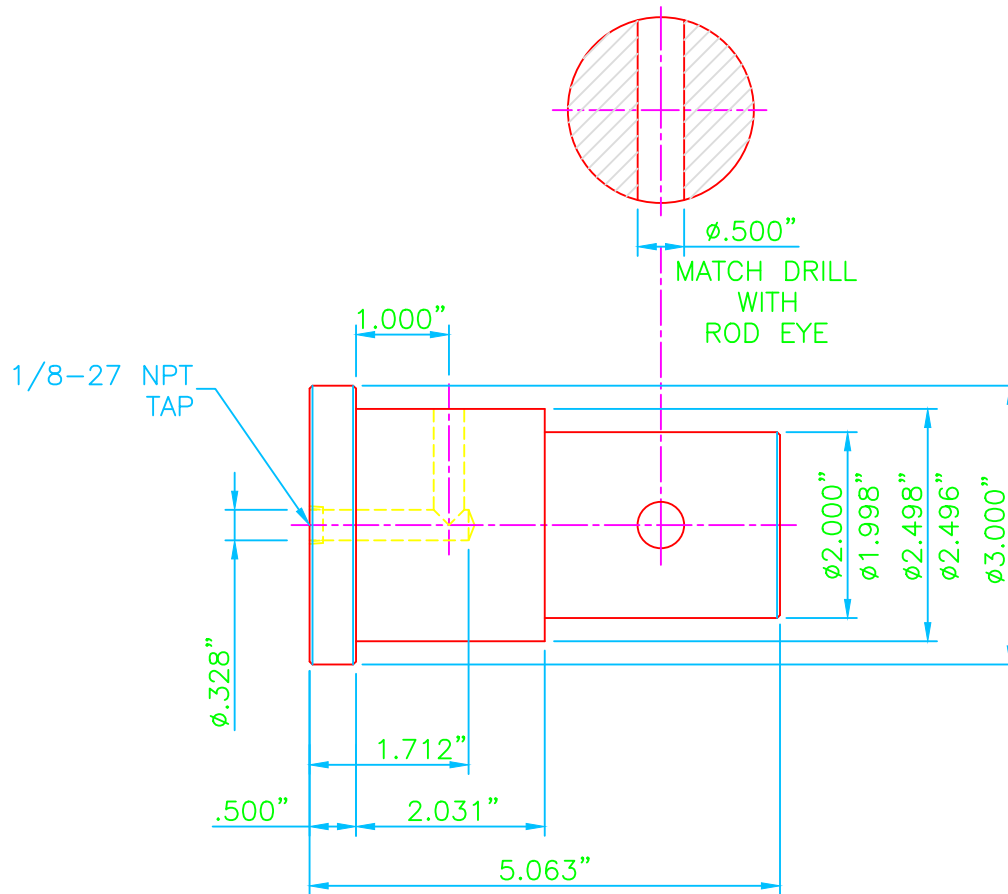

AXLE

N.T.S.

MAT'L: 17-4PH, 3"DIA. ROD
(2) REQ'D

NOTE:
BREAK ALL SHARP EDGES
WITH 1/32" X 45° CHAMFER

Vincent		CORPORATION TAMPA, FLORIDA	
VP-30 PRESS AXLE DETAILS C/O #17, September 25, 2016			
DRAWN	EG	5/12/2016	SIZE
COMP. NAME	07037_Master	B	DRAWING NO.
W. O. NO.	15220	SCALE	N.T.S.
		SHEET	

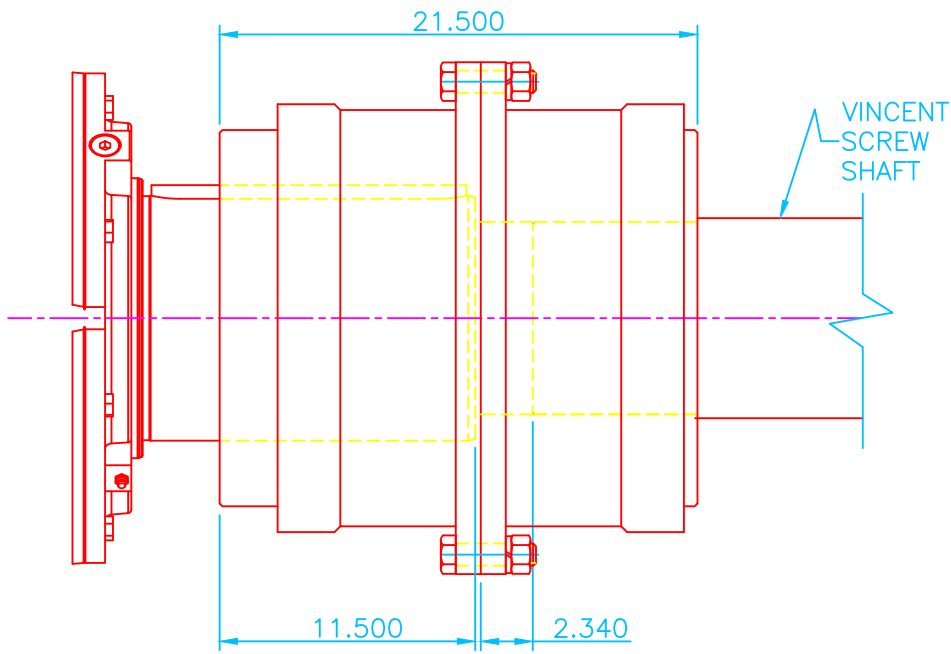

COUPLING MODIFICATION

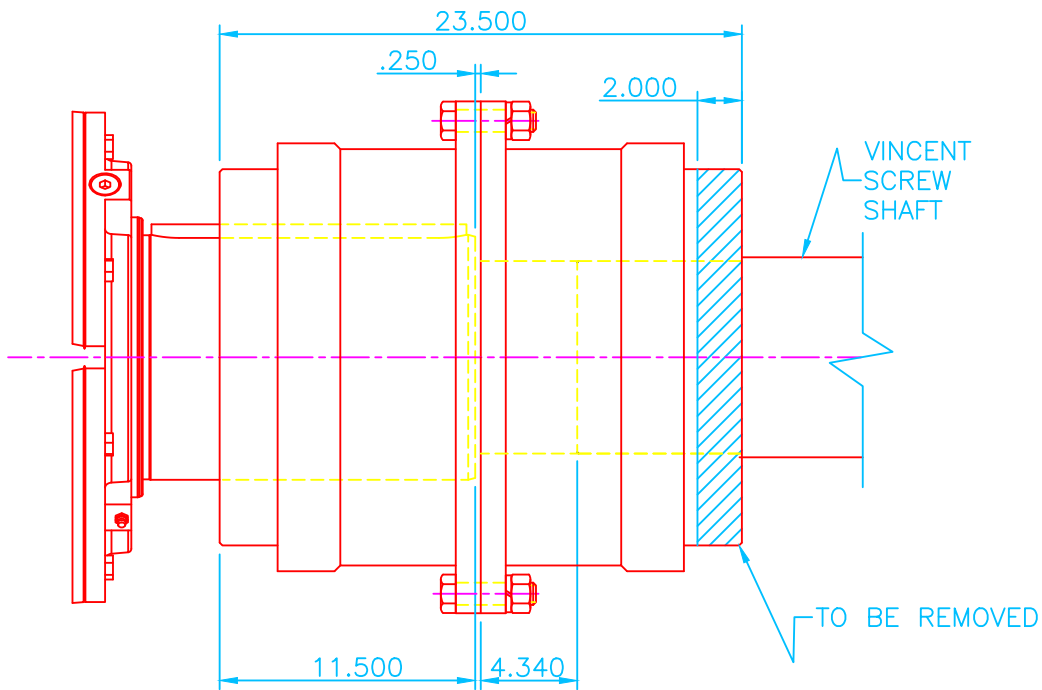

EXISTING COUPLING

Vincent CORPORATION		TAMPA, FLORIDA	
VP-30 PRESS COUPLING MODIFICATION DIAGRAM			
DRAWN	EG	10/3/2016	SIZE
COMP. NAME		07037_Master	B
DRAWING NO.		15220-32	
W. O. NO.		15220	SCALE
		N. T. S.	
			SHEET