

## DIMENSIONAL CONFIRMATION:

1. Q.A. MUST SIGN-OFF THEIR INITIAL ON THE BLANK LINE TO CONFIRM THAT THE DIMENSIONS SHOWN ARE MET.

2. ANY DIMENSION ON THIS DRAWING OUT OF TOLERANCE MUST BE APPROVED BY ENGINEERING.

1A

QA: \_\_\_\_\_

NOZZLE SCHEDULE			
MARK	QTY	SIZE / RATING	DESCRIPTION
N1	1	2" 150# RFWN	INLET
N2	1	2" 150# RFWN	OUTLET
N3	-	-	PRESSURE GAUGE
N4	1	1" 150# RFWN	VENT
N5	1	1" 150# RFWN	CLEAN DRAIN
N6	1	1" 150# RFWN	PURGE

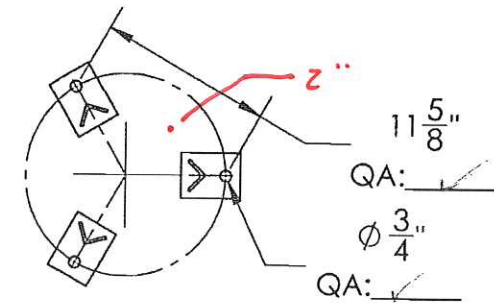
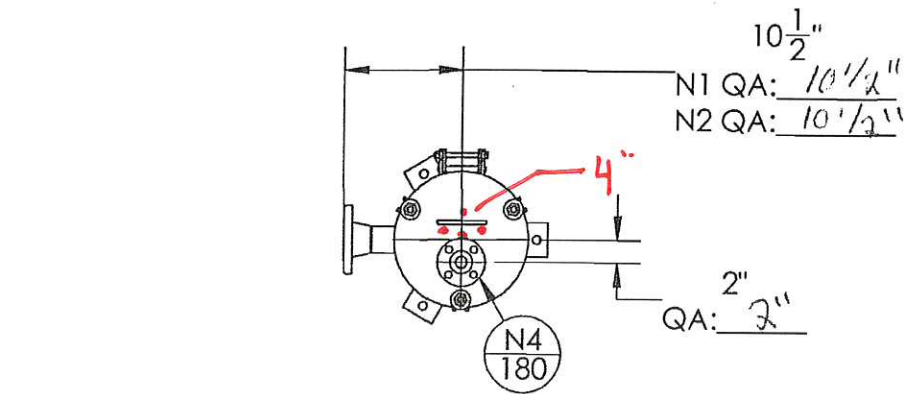

SECTION E-E

SCALE 1 : 12

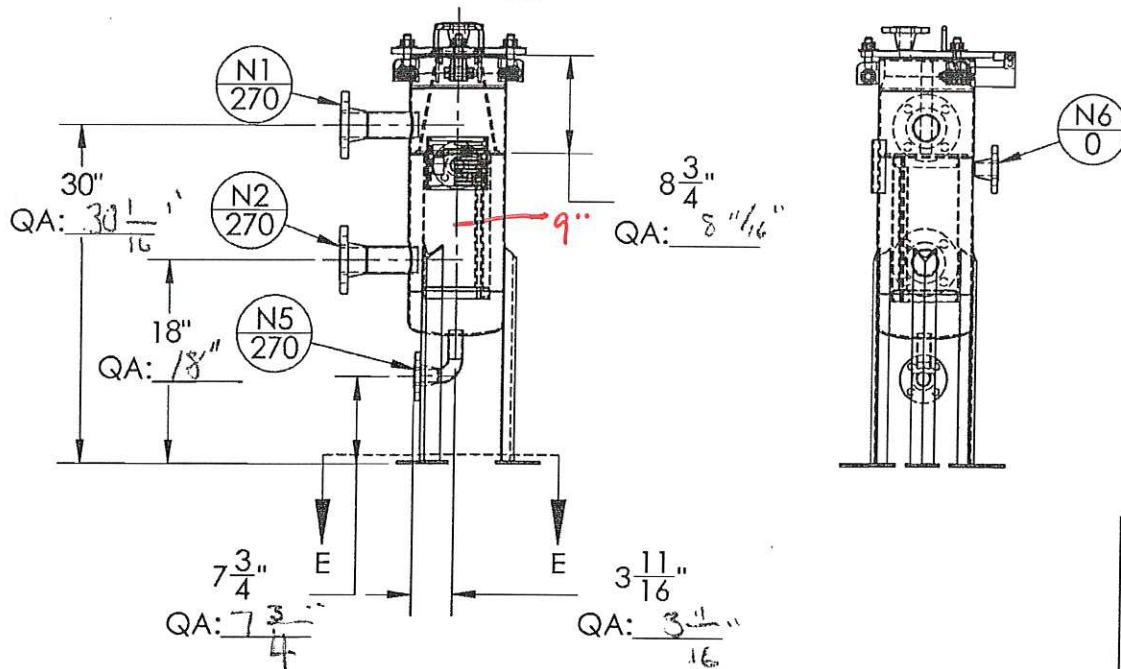

ORIENTATION OF ALL COMPONENTS MUST BE SIGNED OFF BEFORE UNIT CAN SHIP:

QA: ASA PRODUCTION: 7/25

VESSEL A

THIRD ANGLE PROJECTION		FIL-TREK CORPORATION	
TOLERANCES-UNLESS OTHERWISE NOTED		55 Stafford Court Cambridge, Ontario N1T 1B3 Canada	
DECIMAL	.X = ±.1" .XX = ±.02" .XXX = ±.005"	Phone: (519) 623-7448 Fax: (519) 623-8807 Email: info@fil-trek.com Website: www.fil-trek.com	
FRACTIONAL	1/8"	THIS DRAWING IS THE PROPERTY OF 'FIL-TREK CORPORATION' AND MUST NOT BE COPIED OR USED IN ANY WAY DETRIMENTAL TO THE CORPORATION.	
ANGULAR	±.1°	EQUIPMENT: STRAINER BASKET HOUSING (SBO SERIES)	
MAX. MACHINED SURFACE FINISH	125/√	MODEL NO: S6SBDV08-2F-V2	
PARENT: NEW DESIGN		CUSTOMER: OLDS FILTRATION	
DRAWN: JJJ	DATE: 21/08/2015	SERIAL No. V8293	PART No. 003002-00013
CHK'D: CW	SCALE: NTS	DWG. No. 003002-00012-6	
			REV. No. 0