

1 2 3 4 5 6 7 8 9 10 11 12 13 14 15 16 17 18 19 20 21 22 23 24 32 26 27 28 29 30 31

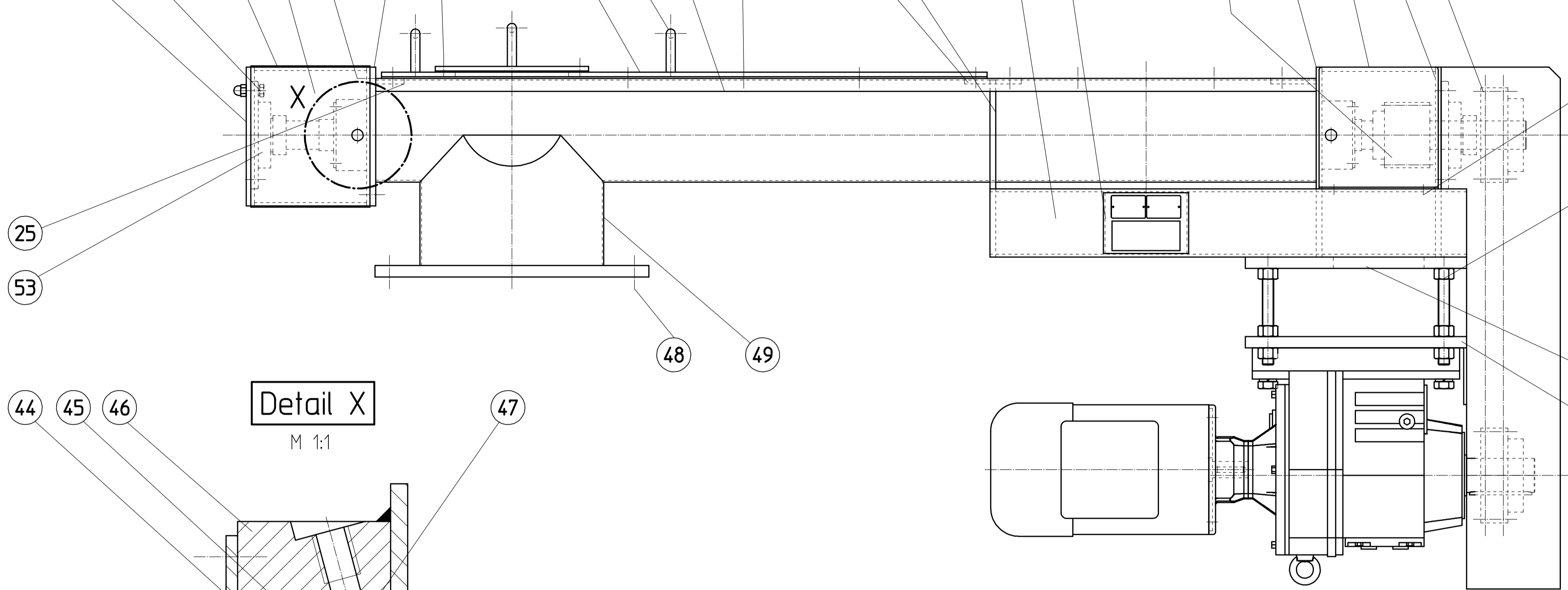

33  
34  
35  
36  
37  
38  
39  
40  
41  
42  
43

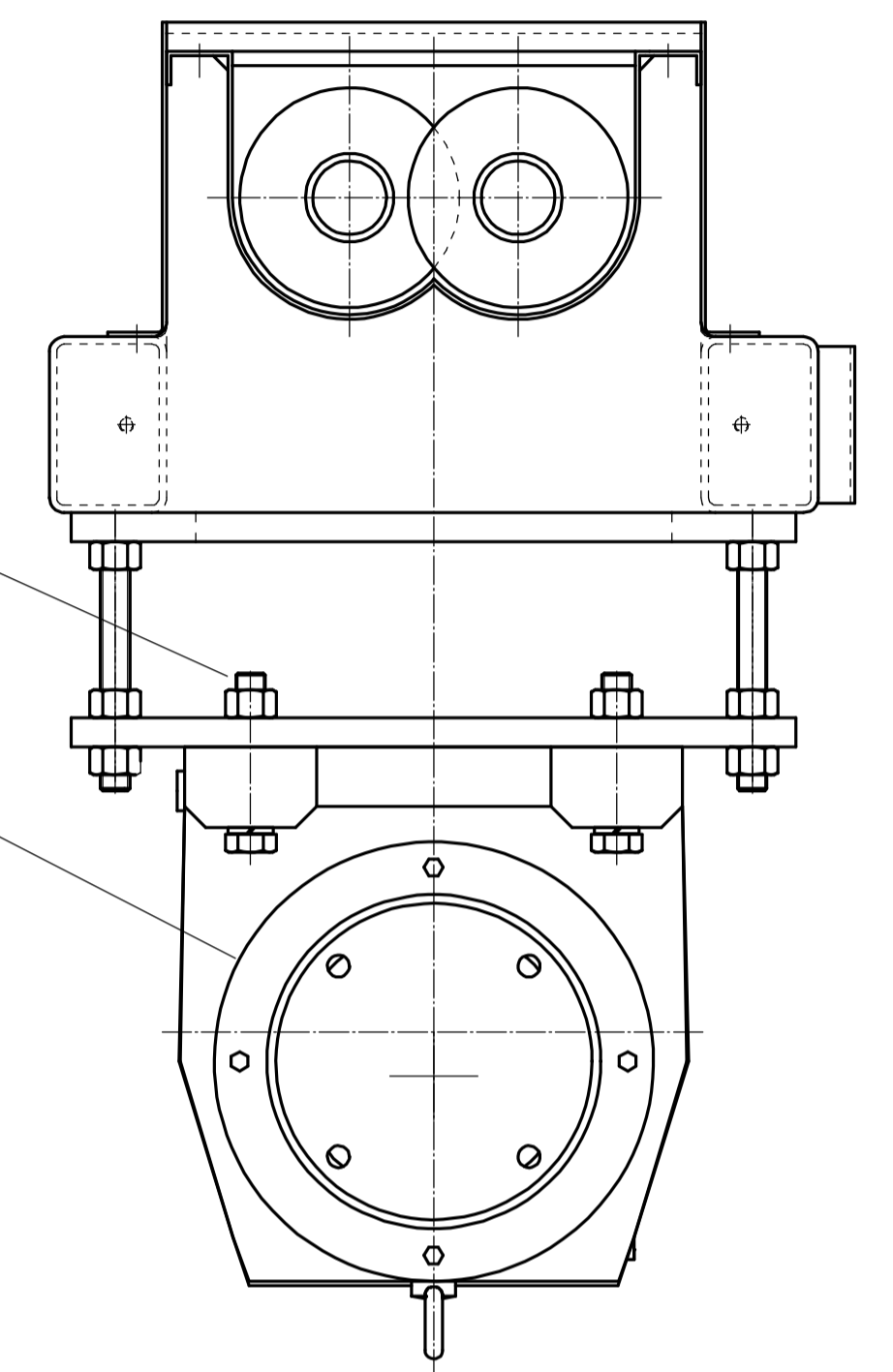

Detail X  
M 1:1

44 45 46

47

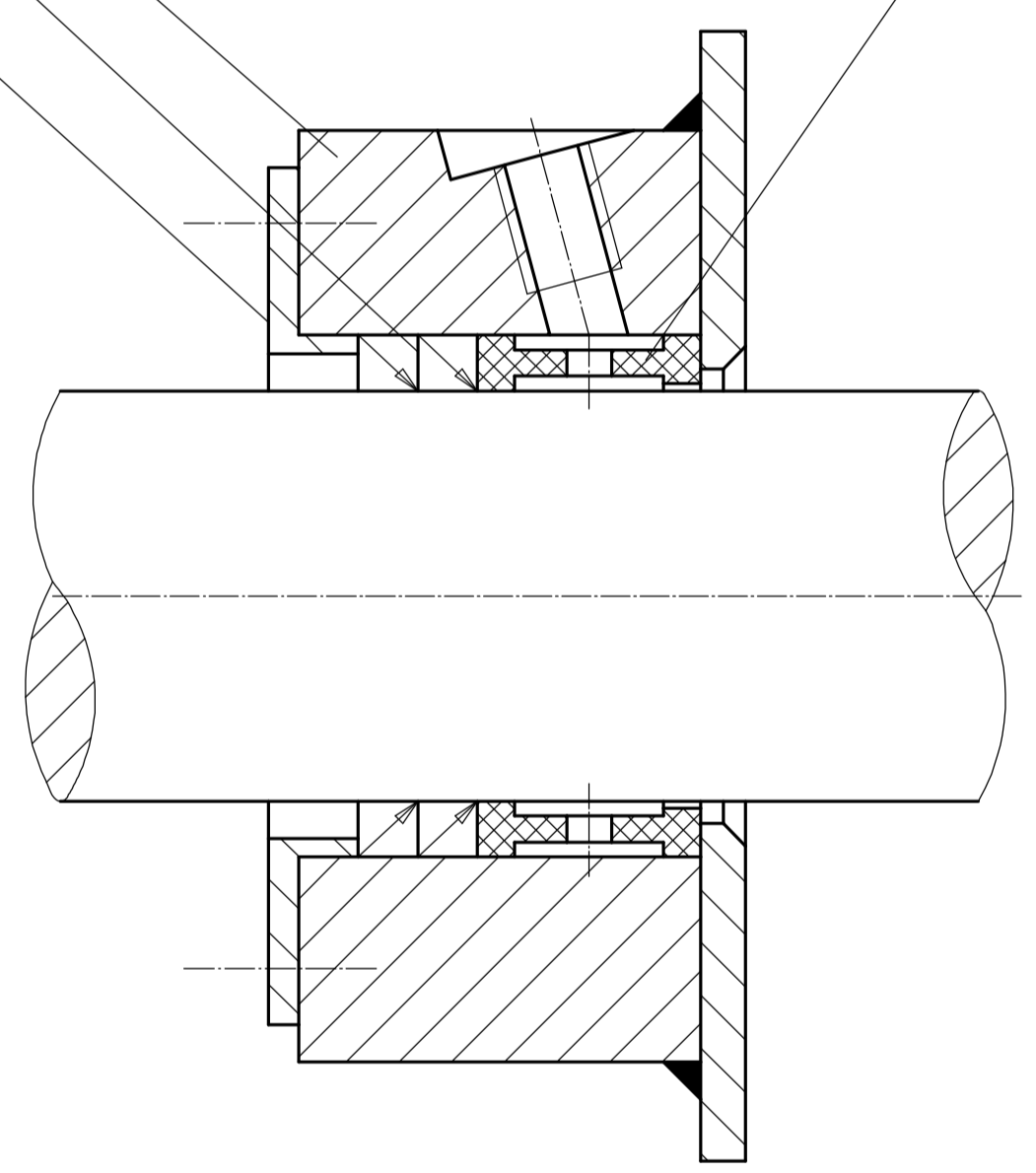

And. / rev.		Datum / date		Name		Beschreibung / description	
Firma / company: BASF USA, Beaumont, Texas				Auftrag / order KA09.37083		Artikel-Nr. / item-no 10005245	
Werkstoff / material: 1.4541 / AISI 321				Gewicht / weight 0		Raummaße / solid measures: LxBxH (mm)	
innen / inside		Oberflächenbehandlung / surface treatment				außen / outside	
innen / inside		Oberflächenschutz / surface finish				außen / outside	
Ersatz für Artikel / subst.							
Maßstab / scale 1:5		Datum / date 01.10.09		Name frenn		 <b>J. ENGELSMANN AG</b> Maschinen für die Verfahrenstechnik	
Gezeichnet / drawn		Geprüft / checked		Freigegeben / release			
Double Screw Conveyor - Trough DSF 150 x 2165 G-891							
Allgemeintoleranzen n. ISO 2768-mK Schulzvermerk n. DIN 34 beachten				Zeichnungs-Nr. / drawing no. 10005245		rev. - 000 - 1030 - 1	
entstanden aus / originated from:							