

ITEM	QTY	RATING	DESCRIPTION
U2	1	4" 300# RF	RECYCLE TAIL GAS INLET
U3	1	4" 150# RF	RECYCLE TAIL GAS OUTLET
U4	1	4" 150# RF	COOLING WATER INLET
U5	1	4" 150# RF	COOLING WATER OUTLET
U6	1	1 1/2" 150# RF	INSTRUMENT AIR
U7	1	1 1/2" FNPT	NITROGEN PURGE
U8	1	1" 300# RF	SKID FLOOR DRAIN
			K.O. POT MAIN DRAIN

MAIN COMPONENT LIST			
ITEM#	TAG#	DESCRIPTION	DATA / INFORMATION
1	PKM-592	HYUNDAI INDUCTION MOTOR	250 HP AT 892 RPM / 460V, 8P, 60Hz
2	PK-592	ARIEL JGJ-2 COMPRESSOR FRAME	3.5" STROKE, 1.50" OD RODS
3	C1	CYLINDER 1: THROW #2	9.75" ID x 3.5" STROKE / 635 PSIG MAWP
4	PK-592-V1A	SUCTION BOTTLE-(CYL.1) THROW #2	18" OD X 30" S/S / MAWP: 400 PSIG @ 350°F
5	PK-592-V2A	DISCHARGE BOTTLE-(CYL.1) THROW #2	18" OD X 48" S/S / MAWP: 500 PSIG @ 350°F
6	C2	CYLINDER 2: THROW #1	9.75" ID x 3.5" STROKE / 635 PSIG MAWP
7	PK-592-V1B	SUCTION BOTTLE-(CYL.2) THROW #1	18" OD X 30" S/S / MAWP: 400 PSIG @ 350°F
8	PK-592-V2B	DISCHARGE BOTTLE-(CYL.2) THROW #1	18" OD X 48" S/S / MAWP: 500 PSIG @ 350°F
9	PK-592-V3	SUCTION SCRUBBER	20" OD X 48" S/S MAWP: 400 PSIG @ 350°F
10	PK-592-E1	RECYCLE COOLER	10.75" OD X 108" SHELL - MAWP: 150 PSIG @ 200°F
11	PK-592-V3A	DISTANCE PIECE K.O. POT	MDMT: -20°F @ 400 PSIG
12	PK-592-V3B	PACKING CASE K.O. POT	TUBE - MAWP: 450 PSIG @ 250°F
13	PK-592-P1A	MAIN OIL PUMP FRAME DRIVEN	10 GPM @ 60 PSI
14	PK-592-H1	CRANKCASE HEATER	750W, 120V-1P-60H
15	PK-592-PM1B	AUX. PUMP MOTOR	2 HP ELECTRIC, 1750 RPM, 460V-3P-60H
16	PK-592-P1B	AUX. OIL PUMP	MMO D3EBCS-143JD: 12.4 GPM @ 75 PSI
17	PK-592-E2	LUBE OIL HEAT EXCHANGER	300 PSIG @ -20F/300F - OIL FLOW, 12 GPM MBTU/MIN
18	PNL-0749B	UNIT CONTROL PANEL	NEMA 4X, CLASS 1, GROUP C/D, DIV. 2
MISC. COMPONENTS			
19		LIFTING LUGS	
20		ANCHOR BOLTS	
21		FLYWHEEL MAJOR O.D. 21.43" x 4.43" WIDE	ARIEL NO. JTM-306
22		COUPLING CMR: SIZE 450; 18.38" ADP; HD BOLTS	REX-THOMAS FLEXIBLE DISC COUPLING
23		PVC 0162 NPS 2 ET 66T; SIZE 40 DVC6200 SS	FISHER CONTROL VALVE: 2"-300# RF CONNECTIONS
24		GATE VALVE RECYCLE COOLER: GAS INBOARD	4"-300# RF CONNECTIONS
25		GATE VALVE RECYCLE COOLER: GAS OUTBOARD	2"-300# RF CONNECTIONS
26		FILTER AUX. LUBE OIL FILTERS	DUPLEX OIL FILTERS #D-7507
27		FILTER MAIN COMP. OIL FILTER	ARIEL CORP. #A-661 SPIN-ON FILTER
28		OIL LEVEL CONTROLLER	KENCO #KLC-9
29		PRESSURE RELIEF VALVE - AUX. LUBE OIL	FULFLO #V-SERIES
30		THERMOSTAT / AUX. LUBE OIL	FPE #S110-170
31		DAY TANK - OIL	20 GALLON CAPACITY
32		PUMP for DAY TANK - OIL	120 PSI / 8.3 BAR ARO 1" DIAPHRAGM PUMP #66100-362-C

SCHEDULE OF OPENINGS			
ITEM#	QTY	RATING	DESCRIPTION
PK-592-V3 SUCTION SCRUBBER BOTTLE			
S1	1	4" 300# RF	TAIL / RECYCLE GAS INLET CONN.
S2	1	4" 300# RF	TAIL / RECYCLE GAS OUTLET CONN. to THROW 2
S3	1	4" 300# RF	TAIL / RECYCLE GAS OUTLET CONN. to THROW 1
S4	1	4" 300# RF	RECYCLE GAS INLET CONN. from COOLER
S5	2	4" 300# RF	INSPECTION OPENING / BLIND FLANGE
S6	1	2" 300# RF	VENT
S7	1	1" 300# RF BLIND	DRAIN
S8	2	1" 300# CPLN	SKIRT VENT
S9	1	2" 300# CPLN	LEVEL SWITCH CONNECTION
S10	1	18" INCH	LEVEL GAGE
P-K-592-V1A SUCTION BOTTLE/CYLINDER 1/THROW TWO			
A1	1	4" 300# RF	TAIL / RECYCLE GAS INLET CONN.
A2	1	1 1/2" 300# RF	VENT CONN.
A3	1	4" 300# RF	INSPECTION PORTAL / BLIND FLANGE
P-K-592-V2A DISCHARGE BOTTLE/CYLINDER 1/THROW TWO			
B1	1	3" 300# RF	TAIL / RECYCLE GAS OUTLET CONN.
B2	1	1 1/2" 300# RF	TI CONN.
B3	1	1 1/2" 300# RF	TE CONN.
B4	1	4" 300# RF	INSPECTION PORTAL / BLIND FLANGE
B5	1	1" 300# RF	DRAIN CONN.
P-K-592-V1B SUCTION BOTTLE/CYLINDER 2/THROW ONE			
C1	1	4" 300# RF	TAIL / RECYCLE GAS INLET CONN.
C2	1	1 1/2" 300# RF	VENT CONN.
C3	1	4" 300# RF	INSPECTION PORTAL / BLIND FLANGE
P-K-592-V2B DISCHARGE BOTTLE/CYLINDER 2/THROW ONE			
D1	1	3" 300# RF	TAIL / RECYCLE GAS OUTLET CONN.
D2	1	1 1/2" 300# RF	TI CONN.
D3	1	1 1/2" 300# RF	TE CONN.
D4	1	4" 300# RF	INSPECTION PORTAL / BLIND FLANGE
D5	1	1" 300# RF	DRAIN CONN.
PK-592-V3A KNOCK-OUT POT/DISTANCE PIECE			
KD1	1	1" NPT	K.O. DRAIN CONNECTION
KV1	1	1" 300# RF	K.O. VENT CONNECTION
LD1	2	3/4" 300# CPLN	LIQUID DRAINER INLET CONNECTION
PK-592-V3B KNOCK-OUT POTS/PACKING CASE			
KD2	1	1" NPT	K.O. DRAIN CONNECTION
KV2	1	1" 300# RF	K.O. VENT CONNECTION
LD2	1	3/4" 300# CPLN	LIQUID DRAINER INLET CONNECTION
PK-592-E1 RECYCLE COOLER / HEAT EXCHANGER			
W1	1	4" 150# RF	COOLING WATER: SHELL SIDE INLET
W2	1	4" 150# RF	COOLING WATER: SHELL SIDE OUTLET
G1	1	4" 300# RF	RECYCLE GAS: TUBE SIDE INLET
G2	1	4" 300# RF	RECYCLE GAS: TUBE SIDE OUTLET
V1	1	3/4" NPT	SHELL SIDE VENT
V2	1	3/4" NPT	SHELL SIDE DRAIN
V3	1	3/4" NPT	TUBE SIDE VENT
V4	1	3/4" NPT	TUBE SIDE DRAIN
LUBE OIL CONNECTIONS CRANKCASE / FRAME			
OF	1	3/4" NPTF	CRANKCASE OIL FILL
OD	1	1/2" NPTF	CRANKCASE DRAIN
OL	1	1" NPTF	L.O. PUMP DISCHARGE PORT
OP	1	1/4" NPTF	CRANKCASE PRIME
OI	1	3/4" NPTF	FILTER INLET
OT	1	1" 150# RF BLIND	DAY TANK LUBE OIL INLET

ONE (1) SKID REQUIRED

NOTES:
 1. UNTIL FABRICATION IS COMPLETE ALL COORDINATES ARE ESTIMATED AND SHOULD BE ASSUMED +/- 2"
 2. CHAIR THRU HOLES "C" ARE Ø1 3/8"
 3. JACK BOLT THRU HOLES "A" ARE Ø1 1/8"
 4. ANCHOR BOLTS ARE Ø1-8 AND 13" PROJECTION ABOVE CONCRETE.
 5. ⊕ = CENTER OF GRAVITY, X=41.62 Y=101.12 Z=29.87
 6. ALL FLANGES IN DIRECT CONTACT WITH HYDROGEN SHALL HAVE 125 RMS FLANGE FACING.
 7. COMPRESSOR/MOTOR SPEED AT FULL LOAD: 892 RPM
 8. SEE DWG# 1423-01-3 FOR LOCATIONS OF CUSTOMER CONNECTIONS

MATERIAL WEIGHTS:		FLYWHEEL:	362 LBS
COMPRESSOR FRAME:	1975 LBS	PIPING & FLANGES: 1", 2", 3" & 4" PIPE	1200 LBS
THROW ONE CYLL LEFT:	1480 LBS	MISC. COMPONENTS:	1000 LBS
THROW TWO CYLL RIGHT:	1480 LBS	RECYCLE COOLER WET:	1574 LBS DRY: 1110 LBS
DRIVE MOTOR:	6019 LBS	SCRUBBER OP-2:	1638 LBS / EMPTY: 1016 LBS
MOTOR COUPLING:	200 LBS	SKID MATERIALS:	9,660 LBS
PULSATION BOTTLES: (IN LBS.)	450 LBS	L.O. SYSTEM & INSTRUMENTATION	450 LBS
OPERATING EMPTY:	250 LBS	PLC PANEL:	250 LBS
THROW #1 SUCTION:	739 LBS	CONCRETE: (1.15 CU. YDS.)	4,080 LBS
THROW #1 DISCHARGE:	927 LBS	GROUT: (4.84 CU. FT.)	650 LBS
THROW #2 SUCTION:	740 LBS	APPROX. TOTAL WEIGHT:	35,351 LBS
THROW #2 DISCHARGE:	927 LBS	EMPTY: 32,674 LBS	
		OPERATING@:	35,351 LBS

CUSTOMER:
 VENTECH XTL OKLAHOMA CITY, OK. LLC
 CUSTOMER PO#: 4777010-14-02793
 CUSTOMER REQ: 4777-010-1222-002-0
 LOCATION: OKLAHOMA CITY
 ITEM NO.: PK-592
 SERVICE: GTL
 TAILGAS RECYCLE COMPRESSOR

NO.	REVISION	DATE	BY
05	CORRECTED CYLINDER DESIGNATION; ADDED REVISION SYMBOLS	3/22/16	DLW
04	ADDED DAY TANK, PUMP AND MISC. ITEMS	2/8/16	DLW
03	CORRECTION OF GA DWG AS PER TRANSMITTAL 0436: 3/10/15	3/10/15	DLW
02	CORRECTION OF GA DWG AS PER TRANSMITTAL 0331: 2/17/15	2/17/15	DLW
01	CORRECTION OF GA DWG AS PER TRANSMITTAL 0209: 1/30/15	1/30/15	DLW
0	FOR APPROVAL	1/14/15	DLW



TURBINE, PUMP & COMPRESSOR, LLC
ENGINEERED PRODUCTS
 3203 LILAC, PASADENA, TX 77505

TITLE		GENERAL ARRANGEMENT FOR PK-592	
		RECYCLE TAIL GAS, ARIEL JGJ-2	
		VENTECH XTL OKLAHOMA CITY, LLC, Δ	
DATE	10/21/14	JOB NO.	1423
SCALE: (APPROXIMATE)	IF 11x17 SHEET THEN 1:57	REVISION	05
	IF 22" x 34" SHEET THEN 1:28.5	DWN.	NKF/DLW
CHECKED BY	N. FEASTER	PAGE	1 OF 1
DWG. NO.		DATE	1423-01

110" INCH MIN DIST. FOR COOLER BUNDLE REMOVAL

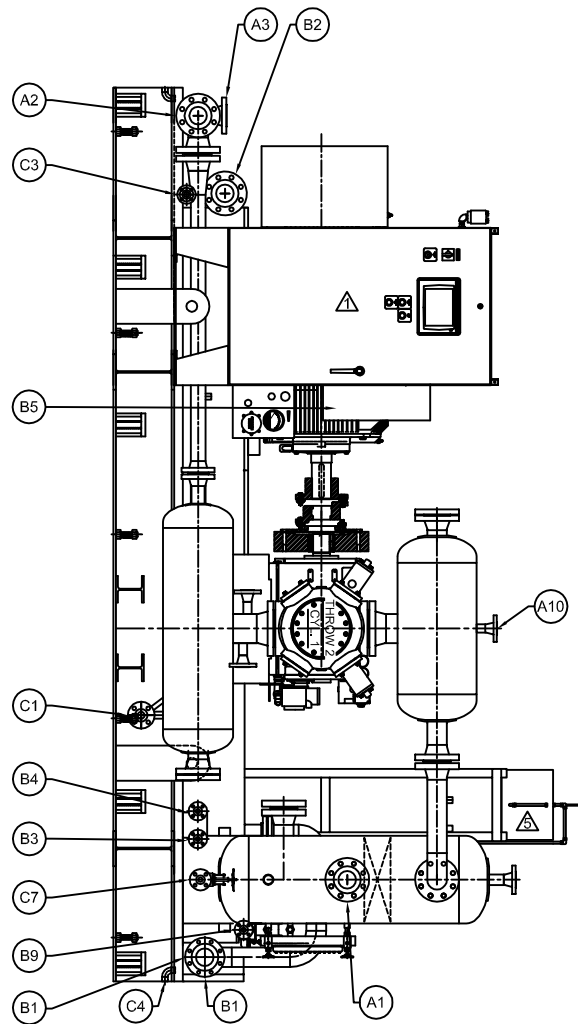

LEFT SIDE

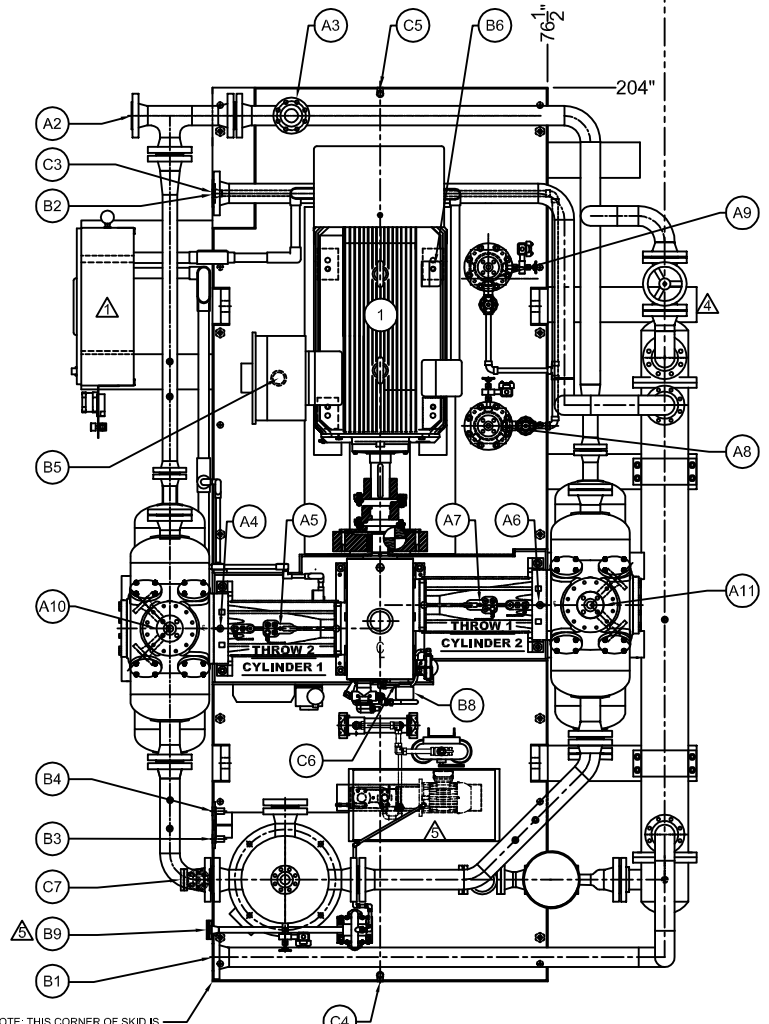

TOP VIEW

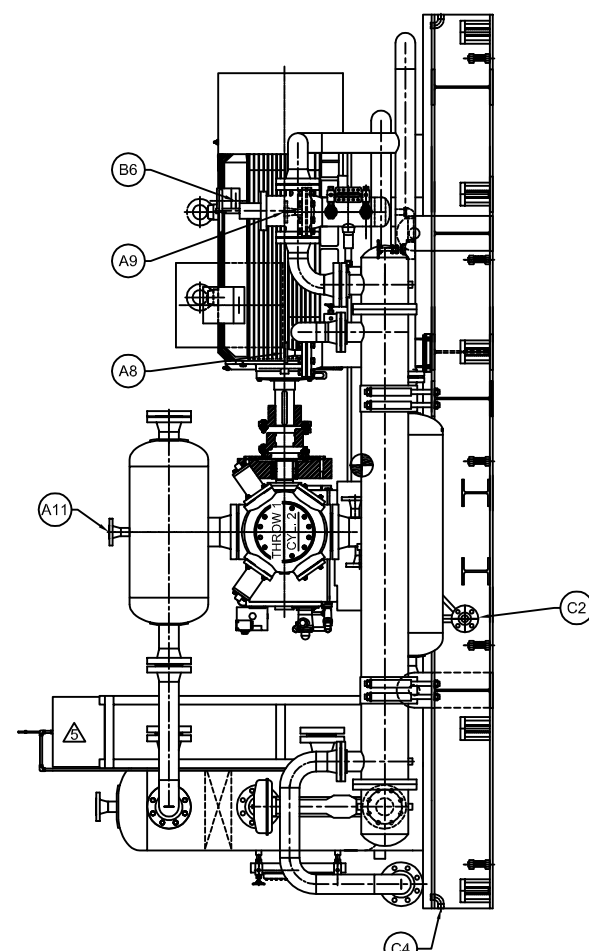

RIGHT SIDE

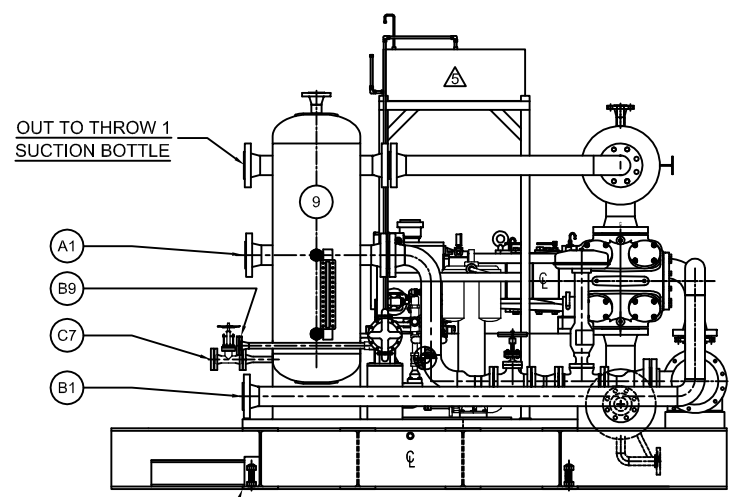

FRONT VIEW

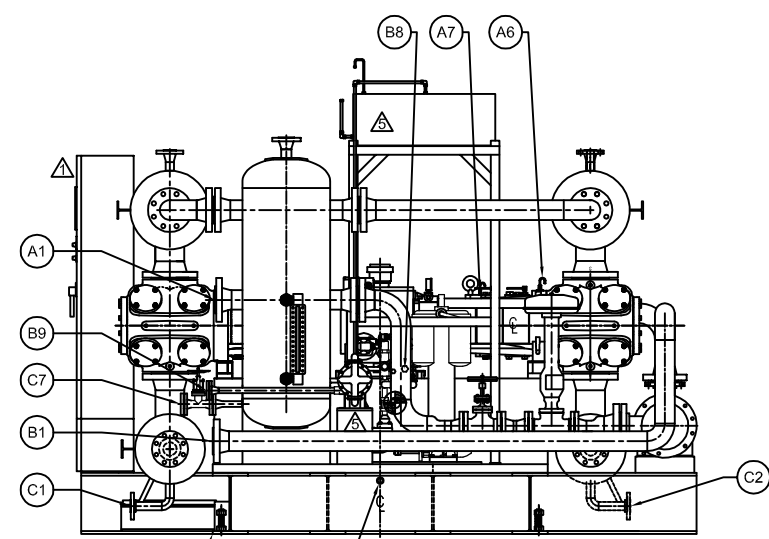

FRONT VIEW

CUSTOMER CONNECTIONS

ITEM	QTY	RATING	DESCRIPTION	COORDINATES / INCHES		
				X	Y	Z
PROCESS GAS CONNECTIONS						
A1	1	4" 300# RF	PROCESS GAS INLET	0.00	23.18	53.44
A2	1	4" 300# RF	PROCESS GAS OUTLET	-18.44	197.44	19.37
A3	1	3" 300# RF	DISCHARGE PRV	18.00	197.44	26.00
A4	1	1/4" FNPT	THROW 2 OUTB. ATMOSPHERIC DIST. PC VENT	1.75	80.50	55.37
A5	1	1/4" FNPT	THROW 2 INB. ATMOSPHERIC DIST. PC VENT	15.44	80.50	54.50
A6	1	1/4" FNPT	THROW 1 OUTB. ATMOSPHERIC DIST. PC VENT	74.75	85.88	55.62
A7	1	1/4" FNPT	THROW 1 INB. ATMOSPHERIC DIST. PC VENT	61.06	85.88	54.50
A8	1	1" 300# RF	DIST. PC K.O. POT VENT TO FLARE	63.00	127.00	47.56
A9	1	1" 300# RF	PRESS. PACKING K.O. POT VENT	63.00	159.56	47.56
A10	1	1 1/2" 300# RF	THROW 2 SUCTION BOTTLE VENT	-9.68	80.50	87.62
A11	1	1 1/2" 300# RF	THROW 1 SUCTION BOTTLE VENT	86.31	85.88	87.62
UTILITY CONNECTIONS						
B1	1	4" 150# RF	COOLING WATER INLET	0.00	5.50	20.94
B2	1	4" 150# RF	COOLING WATER OUTLET	0.00	179.56	31.37
B3	1	1" 150# RF	INSTRUMENT AIR	0.00	32.5	19.50
B4	1	1" 150# RF	NITROGEN PURGE	0.00	38.88	19.50
B5	1	3 1/2" HOLE	MOTOR ELECTRICAL LEADS	15.06	137.68	47.87
B6	1	3/4" MNPT	HEATER BOX / MOTOR	50.25	162.56	58.62
B7			TAG 'B7' NOT USED AT THIS TIME			
B8	1	1" FNPT	FRAME HEATER CONNECTION	43.88	67.25	37.62
B9	1	1" 150# RF	DAY TANK OIL INLET CONNECTION	0.00	11.68	29.62
DRAIN CONNECTIONS						
C1	1	1" 150# RF	THROW 2 DISCHARGE BOTTLE	-9.68	60.75	6.37
C2	1	1" 150# RF	THROW 1 DISCHARGE BOTTLE	86.94	66.12	6.37
C3	1	1" 300# RF	K.O. POT DRAIN	00.00	179.56	16.75
C4	1	1 1/2" FNPT	SKID DRAIN : Compressor End	38.25	0.00	12.18
C5	1	1 1/2" FNPT	SKID DRAIN : Motor End	38.25	204.00	12.18
C6	1	1/2" FNPT	FRAME OIL DRAIN	41.25	68.25	37.18
C7	1	1" 300# RF	SCRUBBER BOTTLE DRAIN	-6.50	23.18	19.94
CENTER OF GRAVITY				41.62	101.12	29.87

COMMENTS: 'B8' IS THE CONNECTION WHERE THE WIRING WILL RUN THROUGH WHEN CONNECTING THE CHROMALOX IMMERSION HEATER FOR THE FRAME OIL. THIS CONNECTION IS ON THE 'TYPE E2' ENCLOSURE ON HEATER.

- NOTES:**
- UNTIL FABRICATION IS COMPLETE ALL COORDINATES ARE ESTIMATED AND SHOULD BE ASSUMED +/- 2"
 - X, Y, Z ZERO DATUM POINT IS THE BOTTOM LEFT CORNER OF SKID FACING THE 'FRONT END'.
 - T.P.C. TO PROVIDE AND INSTALL BLIND FLANGES ON B9 & C7

CUSTOMER: VENTECH XTL OKLAHOMA CITY, OK. LLC
 CUSTOMER PO#: 4777010-14-02793
 CUSTOMER REQ: 4777-010-1222-002-0
 LOCATION: OKLAHOMA CITY
 ITEM NO.: PK-592
 SERVICE: GTL
 TAILGAS RECYCLE COMPRESSOR

DRAWING CONTENT IS PROPERTY OF TURBINE, PUMP AND COMPRESSOR, LLC AND ALL RIGHTS TO DATA HEREIN DISCLOSED REST WITH TURBINE, PUMP AND COMPRESSOR, LLC. NO PART OF THIS DATA MAY BE USED WITHOUT EXPRESS PERMISSION OF TURBINE, PUMP AND COMPRESSOR, LLC.

NO.	REVISION	DATE	BY
07	CORRECTED CYLINDER DESIGNATION; ADDED REVISION SYMBOLS; REMOVED BY CONNECTION FROM TABLE	DLW	3/22/16
06	CORRECTED FLANGE RATING B9 & C7; ADDED NOTE	DLW	3/11/16
05	CORRECTION OF SA DWG AS PER TRANSMITTAL 0408-327115 AND ADDED DAY TANK, PUMP AND MISC. ITEMS	DLW	1/15/16
04	MOVED OUTRIGGER BEAMS AS PER STUDY; ADDED ITEM B8 & CORRECTED NOTE C1 AND C7	DLW	3/10/15
03	ADDED 2ND FRONT VIEW FOR CLARITY	DLW	2/17/15
02	CHANGED 'C3' TO 1"-300# RF CONNECTION	DLW	2/10/15
01	ADDED CONTROL PANEL	DLW	2/2/15

ONE (1) SKID REQUIRED

TURBINE, PUMP & COMPRESSOR, LLC
ENGINEERED PRODUCTS
3203 LILAC, PASADENA, TX 77505

LOCATION of CUSTOMER CONNECTIONS
RECYCLE TAIL GAS, ARIEL JGJ-2
VENTECH XTC OKLAHOMA CITY, LLC.

DATE: 12/04/14 JOB NO.: 1423 SCALE: NTS REVISION: 07
 DWN: DLW CHECKED BY: N. FEASTER PAGE: 1 OF 1 DWG NO.: 1423-01-3