



Mechanical Separation
Division

102116
102117
102118

Westfalia Separator

Instruction Manual

CF-FH4011

No.: 8177-9001-204
Edition: 10.02.2006
Designation: Clarifying decanter with disk stack and 2-gear drive
Model: PA 756-00-32

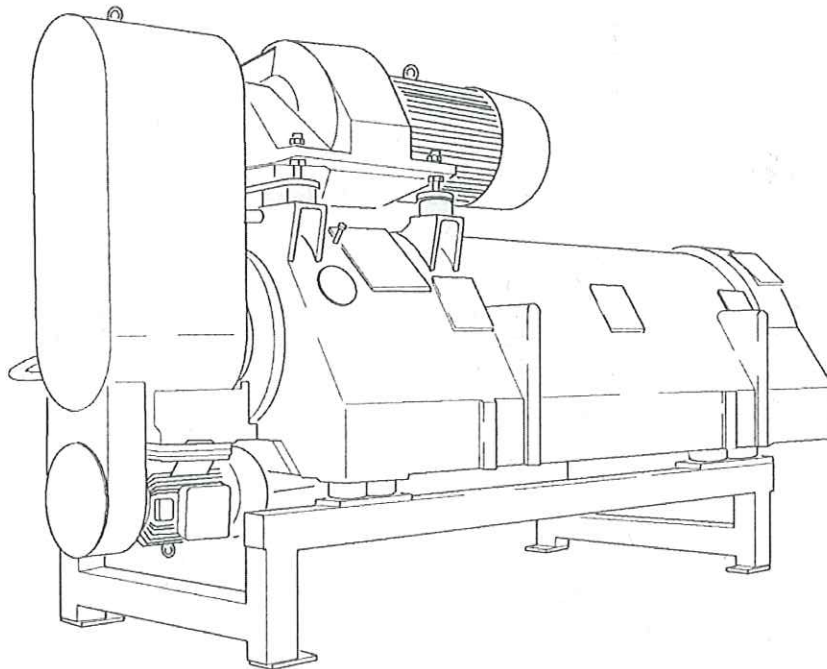

		<input type="text"/>	
D-59302 Oelde (F. R. Germany)			
Model	<input type="text"/>	S/N	<input type="text"/>
Built in	<input type="text"/>	Ø in mm	<input type="text"/>
Max. admissible rated bowl speed in min ⁻¹			<input type="text"/>
Max. admissible density in kg/dm ³ of product			<input type="text"/>
Heavy liquid kg/dm ³	<input type="text"/>	Solids kg/dm ³	<input type="text"/>
min/max throughput m ³ /h			<input type="text"/>
min/max temp. of product in °C			<input type="text"/>
min/max housing in bar			<input type="text"/>

*This page must be filled in by the operator.
Please transfer the data from the decanter nameplate.*

For your safety



- **Warning in case of danger to machine parts. Strictly adhere to instructions marked with this symbol.**

This avoids damage or destruction of the decanter and other equipment.



- **Take special care when carrying out operations marked with this symbol –**

otherwise danger to life.

- **Observe accident prevention regulations.**

The local safety and accident prevention regulations apply unconditionally to the operation of the decanter.

- **Refer to the instruction manual.**

Follow only the instructions given in this manual.

- **Operate the decanter only in accordance with agreed process and operating parameters.**

- **Maintain the decanter as specified in this instruction manual.**

- **Carry out safety checks on the decanter,**

as described in the chapter "Safety precautions" in this manual.

- **Liability for the function of the machine passes to the owner.**

Liability for the function of the machine passes unconditionally to the owner or operator irrespective of existing warranty periods in so far as the machine is improperly maintained or serviced by persons other than Westfalia Separator personnel or if the machine is not applied in accordance with the intended use.

Westfalia Separator AG shall not be liable for damage which occurs as a result of non-compliance with the above. Warranty and liability conditions in the Conditions of Sale and Delivery of Westfalia Separator AG are not extended by the above.

1	Safety precautions	9
1.1	Correct usage	10
1.2	Incorrect usage	10
1.3	Safety markings on the decanter	11
1.3.1	Out-of-date safety stickers (used until 2004).....	12
1.4	Demands relating to service personnel and spare parts	13
1.5	Operations on the decanter	13
1.5.1	Assembly	14
1.5.2	Electrical installation	15
1.5.3	Before start-up	16
1.5.4	Operation	17
1.5.5	Voltage cut-off during operation	19
1.5.6	Shut-down and »Emergency-Off«	19
1.5.7	Maintenance and servicing	20
1.6	Decommissioning, standstill times, storage.....	22
1.7	Corrosion	23
1.8	Erosion.....	24
2	Machine description	25
2.1	Main components of the decanter	27
2.1.1	Bowl	27
2.1.2	Housing.....	27
2.1.3	Lubrication	28
2.1.4	Bearing temperature monitoring	28
2.1.5	Drive.....	28
2.1.6	Motor control.....	30
2.2	Cyclo gear.....	30
2.3	Operating principles of the decanter.....	31
2.4	Throughput	31
2.5	Oil lubrication	33
2.5.1	Connections.....	35
2.6	Motor data.....	36
3	Operation	39
3.1	Operation	40
3.1.1	Start preparations	40
3.1.2	Start-up	40
3.2	Operation	41
3.2.1	Operation with a vibration monitoring system.....	41
3.2.2	Shut-down and ordinary cleaning	42
3.2.3	Flushing the decanter before operation	42
3.3	Thorough cleaning	42
3.4	Long-term shut-down.....	43
3.5	Operating faults	44
3.5.1	Start-up problems	44
3.5.2	Bearing temperature too high	44
3.5.3	Vibrations too high	44

4 Maintenance**45**

4.1	Avoiding accidents.....	46
4.2	Lubrication and maintenance schedule.....	47
4.3	Demands relating to service personnel and spare parts.....	47
4.4	Service and maintenance contract with Westfalia Separator.....	47
4.5	Instructions on handling roller bearings.....	48
4.6	Screw tightening torques.....	49
4.6.1	Screw tightening torques in inch-pound (inlb).....	50
4.7	Scroll.....	51
4.7.1	Permissible wear to scroll.....	51
4.7.2	Removing the scroll.....	52
4.7.3	Replacing the scroll.....	53
4.7.4	Fitting the scroll.....	56
4.8	Bowl.....	58
4.8.1	Removing the bowl.....	58
4.8.2	Fitting the bowl.....	60
4.8.3	Replacing the wearing bushes.....	61
4.9	Replacing the scroll bearings.....	62
4.9.1	Scroll bearing - liquid side.....	62
4.9.2	Removing the scroll bearings (solids side).....	66
4.9.3	Fitting the scroll bearings (solids side).....	67
4.10	Replacing the main bowl bearings.....	70
4.10.1	Removing the main bowl bearings (liquid side).....	70
4.10.2	Fitting the main bowl bearings (liquid side).....	72
4.10.3	Removing the main bowl bearing (solids side).....	76
4.10.1	Fitting the main bowl bearings (solids side).....	78
4.11	Drive belts.....	80
4.11.1	Drive belts (primary drive).....	80
4.11.2	Drive belts (secondary drive).....	82
4.12	Bearing change - oil feed.....	83
4.12.1	Bearing change — drive (transmission house).....	84
4.13	Oil circulation lubrication system.....	90
4.14	Cyclo gear.....	91
4.14.1	Dismantling the secondary gear.....	91
4.14.2	Assembling the secondary gear.....	92
4.14.3	Primary gear.....	92
4.15	Gaskets.....	93
4.15.1	Radial sealing rings.....	93
4.15.2	Important mounting instructions for Elrings.....	94
4.16	Motor bearings.....	94

5 Installation and adjustment**95**

5.1	Instructions for planning the installation.....	96
5.1.1	Special aspects to consider when operating in hot conditions.....	97
5.2	Installation.....	99
5.2.1	Drive belts (primary drive).....	100
5.2.2	Direction of rotation.....	100
5.2.3	Regulating ring.....	101
5.2.4	Removing the regulating ring.....	101
5.2.5	Fitting the regulating ring.....	101
5.2.6	Dismantling the disk stack.....	102
5.2.7	Installing the disk stack.....	103
5.3	Table of speeds.....	104
5.4	Altering the speed.....	105
5.4.1	Replacing the exchangeable motor pulley.....	106

5.4.2	Replacing the exchangeable decanter pulley	107
5.4.3	Replacing the motor belt pulley	108
5.4.4	Replacing the decanter belt pulley	109

Note
Notes
Notizen
Anotaciones
Notizen
Notes
Note

1 Safety precautions

1.1	Correct usage	10
1.2	Incorrect usage	10
1.3	Safety markings on the decanter	11
1.3.1	Out-of-date safety stickers (used until 2004).....	12
1.4	Demands relating to service personnel and spare parts	13
1.5	Operations on the decanter	13
1.5.1	Assembly	14
1.5.2	Electrical installation	15
1.5.3	Before start-up	16
1.5.4	Operation	17
1.5.5	Voltage cut-off during operation	19
1.5.6	Shut-down and »Emergency-Off«	19
1.5.7	Maintenance and servicing	20
1.6	Decommissioning, standstill times, storage.....	22
1.7	Corrosion	23
1.8	Erosion.....	24

1.1 Correct usage

Decanters are used for the separation of liquid mixtures or for the separation of solids out of liquids or liquid mixtures.

The following parameters were taken into consideration when designing the decanter:

- The chemical and physical properties of the product to be processed (density etc.).
- The temperatures, pressures and throughput capacities encountered during processing.
- The admissible operating materials (cleaning agents, lubricants etc.)

The decanter may only be operated in accordance with the contractually agreed provisions.

1.2 Incorrect usage

In the view of Westfalia Separator, misuse of the decanter would involve one or more of the following points:

- The product fed does not conform to the specifications on the nameplate.
 - The density of the product is too high.
 - The temperature of the product is too high.
- The maximum admissible bowl speed is exceeded as a result of manipulating the drive.
- The decanter is operated when not completely and properly assembled.
 - The required supervisory equipment is not activated.
 - The required protective covers are not installed.
- The decanter is operated by persons who have not been adequately trained.
- The decanter is operated with spare parts that do not originate from Westfalia Separator.



Each point listed represent incorrect usage and can result in severe damage to property and personal injury.

Prior to any intended deviation from the agreed operating mode, it is therefore imperative to obtain the consent of Westfalia Separator.

1.3 Safety markings on the decanter

The following safety markings must be attached to the machine as self-adhesive stickers. The stickers must always be in perfect condition.

- Clean dirty stickers.
- Replace damaged stickers. The part number is situated at the bottom right on each sticker.

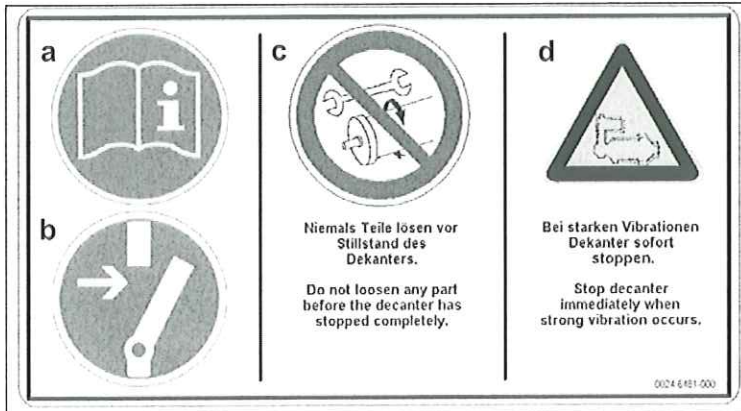

Fig. 1

This multi-sticker is attached to every decanter. It is available in several language combinations.

Meaning of the stickers:

- Pay attention to the instruction manual (a).
- Disconnect the power to the decanter before carrying out maintenance work (b).
- Never loosen parts before the decanter has come to a standstill (c).
- Shut down the decanter immediately when severe vibrations occur (d).

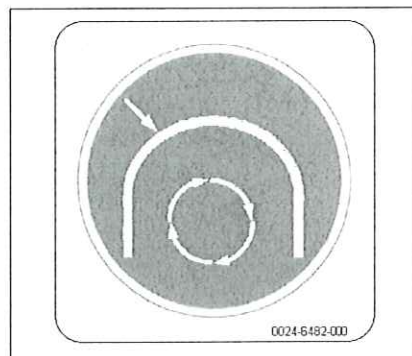

Fig. 2

- Operate the machine only with protective equipment in accordance with EN 294.



Fig. 3

- Warning against hot surfaces. This sticker is used only under hot operating conditions (product temperatures above 80 °C).

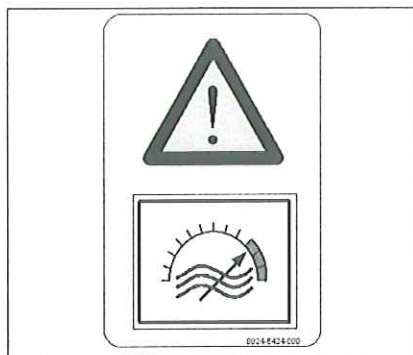

Fig. 4

- Never manipulate the frequency converter to exceed the permissible bowl speed (see nameplate). Is used only with frequency converter operation.

1.3.1 Out-of-date safety stickers (used until 2004)

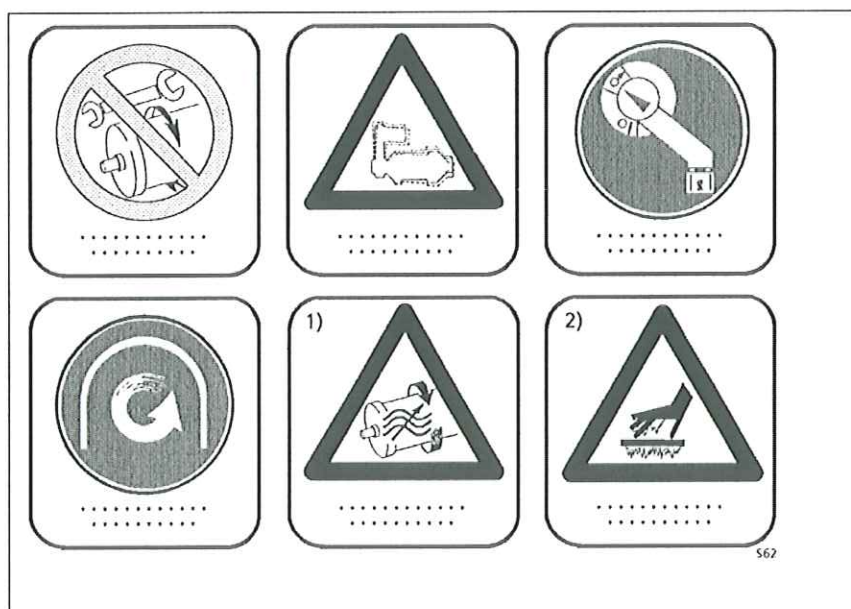

Fig. 5

- 1) Only in case of operation with frequency converter
- 2) Only in case of hot operation

1.4 Demands relating to service personnel and spare parts



Fig. 6

- Use only genuine spare parts from Westfalia Separator.

The use of non-genuine parts leads to:

- Safety risks
- Lower durability and availability
- Increased maintenance requirement

If a safety risk arises, this may have legal consequences for the responsible persons. In this case, Westfalia Separator shall assume no liability or warranty.

- Deploy only well trained personnel for maintenance work, e.g. the service personnel from Westfalia Separator or personnel trained by Westfalia Separator.
An incorrectly maintained/assembled machine poses a safety risk for the operators.

1.5 Operations on the decanter

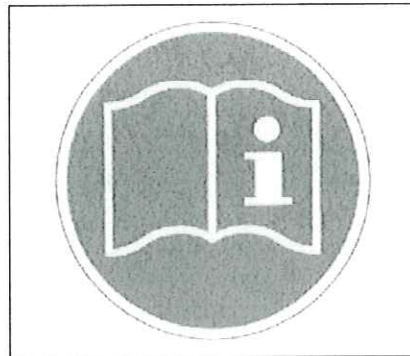

Fig. 7

The decanter works reliably, provided that it is operated and looked after in accordance with our operating instructions.

Special attention must be given to:

- Installation
- assembly
- start-up
- Operation
- shut-down
- Maintenance and servicing

1.5.1 Assembly

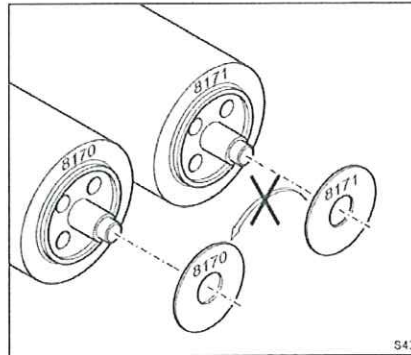

Fig. 8

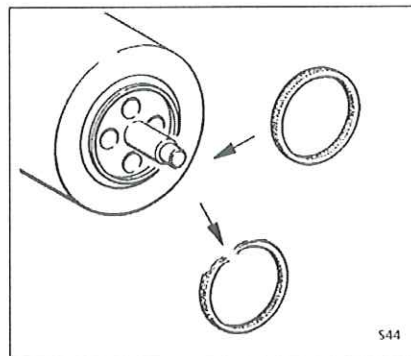

Fig. 9

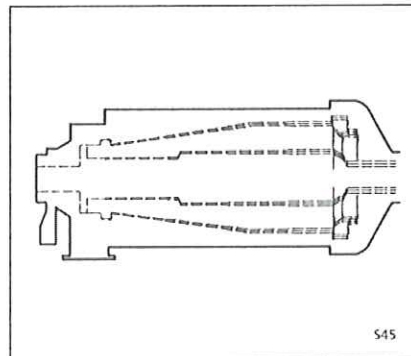

Fig. 10

- If the plant has several centrifuges, be careful not to interchange parts of different machines.

- Damaged parts must be replaced immediately by new or reconditioned parts.

- Certain bowl and scroll spare parts are pre-assembled and balanced by Westfalia Separator AG. These parts are marked with 3 or 4 in the "ETS" column. In order to avoid imbalance, Westfalia Separator AG must be consulted when exchanging these parts.

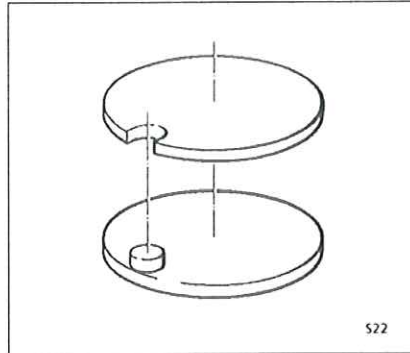

Fig. 11

- The bowl parts are arranged in fixed positions relative to one another. Locking devices and alignment marks must be in perfect condition. The bowl must not be operated if these locking devices and alignment marks are not in perfect condition.

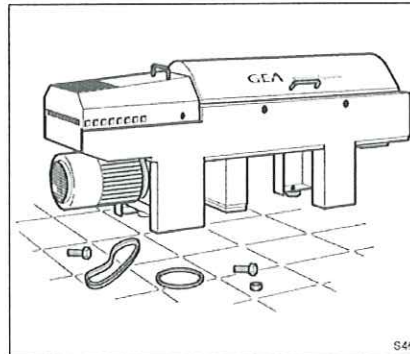

Fig. 12

- When assembling the bowl, be sure to strictly adhere to the instructions given in chapter 4, in order to avoid undue unbalance.
- Check if the machine is completely assembled and properly installed.

1.5.2 Electrical installation

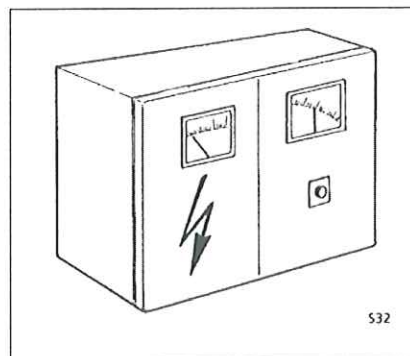

Fig. 13

- Local regulations governing electrical installations and apparatus must be observed.
- The frequency and voltage of the power supply must comply with the machine specification.
- Carry out potential equalization.
- Observe legal regulations within the EU, e.g.:
 - Low-voltage guide-line 73/23/EWG
 - Electro-magnetic compatibility 89/336/EWG

1.5.3 Before start-up

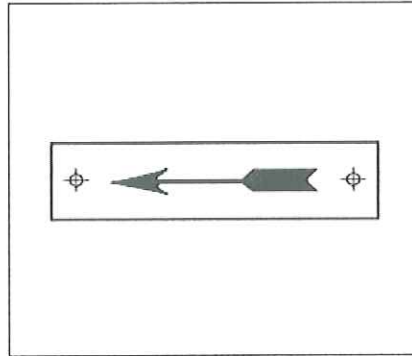

Fig. 14

- The bowl must rotate in counter-clockwise direction when looked at from the drive side (see arrow on housing or protective hood).

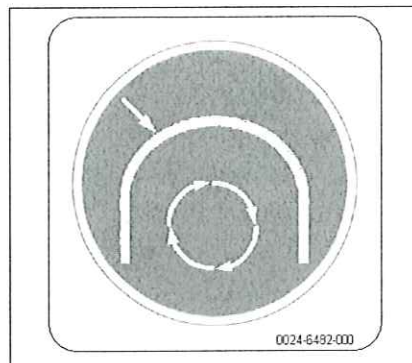

Fig. 15

- The decanter may only be operated with protection devices conforming to EN 294.
 - Equip solid and liquid discharges accordingly.

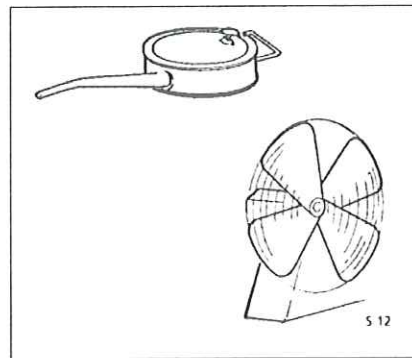

Fig. 16

- Check that the lubrication and cooling systems are serviceable.

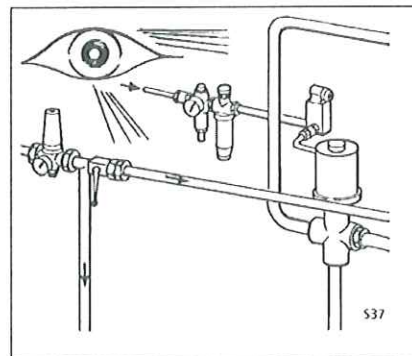

Fig. 17

- Check that the product paths are set to operation.
- Regularly check hose pipes for signs of ageing.
- Check sight glasses for mechanical damage.
- Damaged parts must be replaced immediately by new or reconditioned parts.

1.5.4 Operation

GEA Westfalia Separator D-53072 Overath (F. R. Germany)		Industry GmbH
Typ	CA 505-28-30	M.Nr.
Baujahr	2002	Ø Di in mm
max. zulässige Trommel-Nendrehzahl in min ⁻¹ (rpm)		2150
max. zulässige Dichte in kg/dm ³ des Aufgabegutes		
Schwere Flüssigkeit kg/dm ³		Feststoff kg/dm ³ 1,3
min/max Durchsatz m ³ /h (gpm)		3 - 250 (13,2 - 1100)
min/max Temp. des Aufgabegutes in °C (°F)		5 - 60 (41 - 140)
min/max Gehäusedruck in bar (psi)		

Fig. 18

- Refer to chapter »Operation«.
- Note nameplate. The values for
 - Bowl speed
 - density of heavy liquid
 - density of solids (centrifugally dry)
 are maximum values and may not be exceeded.



Fig. 19

- Wear ear protection.



Fig. 20

In case of frequency converter operation:

- Never manipulate the frequency converter to exceed the permissible bowl speed (see nameplate).
- The machine may only be operated with an independent device for speed limitation.



Fig. 21

- Do not feed product which is categorised as explosive.
- Inert gas blanketing is not possible.



Fig. 22

- When processing products harmful to persons, observe the pertinent safety regulations.
 - Refer to the safety data sheet of the product.
 - Wear protective clothing.



Fig. 23

Only in the case of hot operation:

- Product-contacting parts reach temperatures over 80 °C.
 - pipes and hoses
 - collectors



Fig. 24

- Shut down the decanter immediately when unusual noises, vibrations or overheating occur.

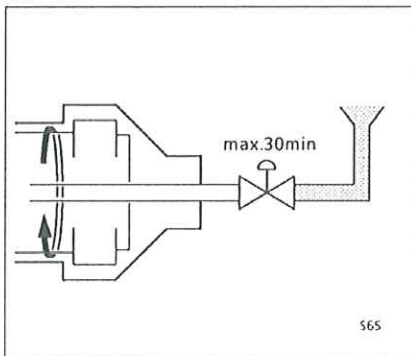

Fig. 25

- The bowl is not allowed to run without liquid supply for more than 30 minutes, as otherwise it would result in overheating of the bowl material.

1.5.5 Voltage cut-off during operation

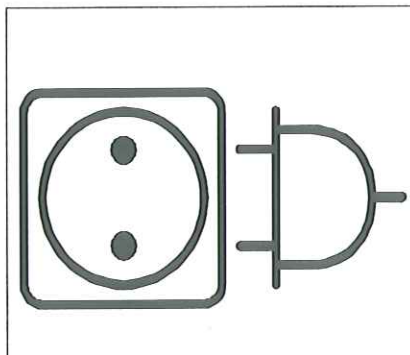

Fig. 26

If the voltage is interrupted for more than one second during operation, the motor control creates the following state:

- Bowl drive "OFF"
- Post-running time "ON"

When the voltage returns, post-running time "ON" means:

- The oil circulation lubrication system starts (if fitted)
- The scroll drive starts

It makes no difference whether the voltage returns after 2 seconds or 3 hours.

After a brief voltage cut-off, the bowl is cleared by the scroll when it re-starts. Solids caking or hardened deposits in the machine are prevented.

Do not start maintenance work on the decanter until the following conditions are met:

- The main switch is kept in position "OFF" by means of a locking mechanism.
- The decanter is at standstill.

1.5.6 Shut-down and »Emergency-Off«

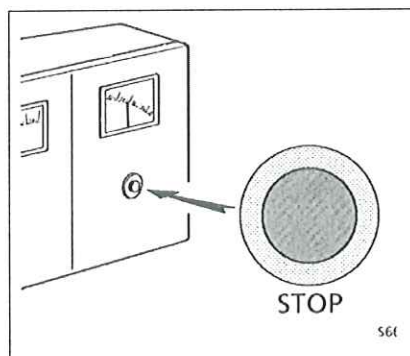

Fig. 27

- Refer to section »operation«.

1.5.7 Maintenance and servicing

Unfavourable operating conditions may require shorter maintenance intervals. The factors listed below are unfavourable because they either attack the decanter material directly or impair the lubrication/cooling system.

- aggressive product (chemical or physical)
- high product temperature
- product with grease decaying properties
- environment: temperature, dust, vapours

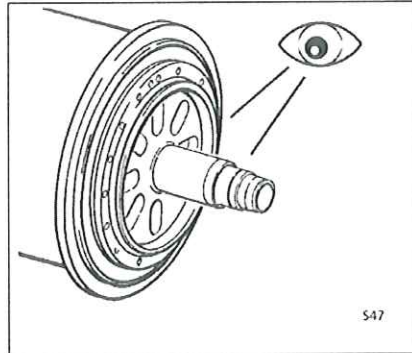

Fig. 28

Particularly highly stressed parts of the decanter such as bearing hub, bowl hub and other bowl parts with a large outer diameter must be checked on a regular basis to ensure safe and efficient operation.

Timely maintenance and replacement of worn or damaged machine parts are essential for safe operation of the decanter.



Maintenance and repair work may only be carried out by the customer to the extent described in this instruction manual.

Always clean the machine thoroughly. Uneven solids deposits in the bowl or on the scroll cause serious imbalance.



Maintenance and repair work not described in this manual may only be carried out by the manufacturer or by "central repair shops" authorized by the manufacturer.

We recommend having your decanter serviced by our specialists at regular intervals. Such inspections will help keep your decanter working reliably and prevent undesirable shut-downs.

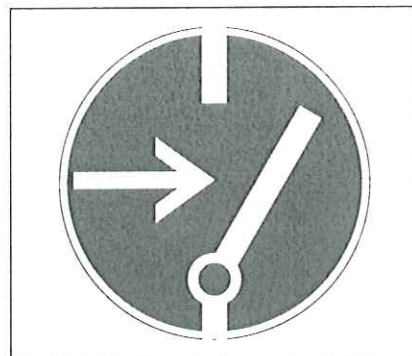

Fig. 29

Before maintenance and servicing:

- Switch off all electrical apparatus via the main switch.
- Secure the installation against unintended restarting with locking devices.

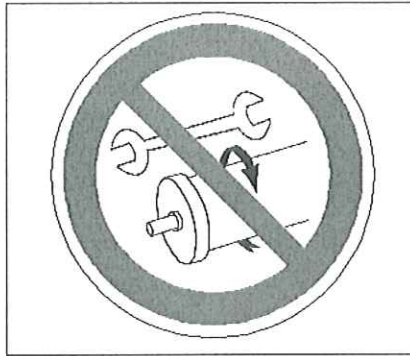

Fig. 30

- Do not loosen any part before the bowl has come to a standstill.



Fig. 31

- Do not climb onto or stand on the machine or parts of the machine.
- Make provision for and use sturdy working platforms.

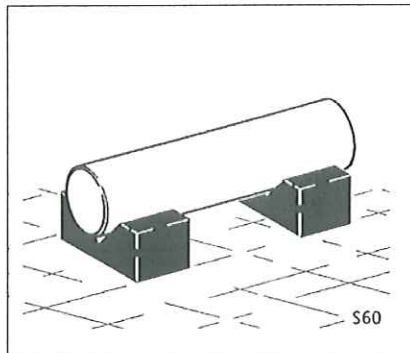

Fig. 32

- Place dismantled machine parts on a suitable base, e.g. a rubber mat.
- Take steps to prevent machine parts from overturning and rolling away.

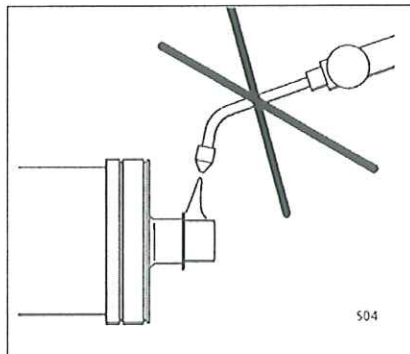

Fig. 33

- Do not heat bowl parts with a naked flame.
- Bowl parts must never be welded.
- Even during cleaning the bowl parts the temperature must not exceed 100 °C.

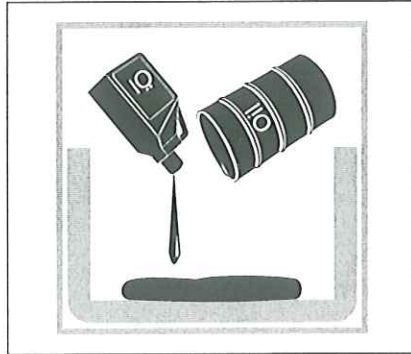

Fig. 34

- Collect dripping oil to prevent danger of slipping and product infection.
- When handling waste oils note:
 - They can be injurious to health depending on their chemical composition.
 - Waste oil must be disposed of in accordance with local regulations.

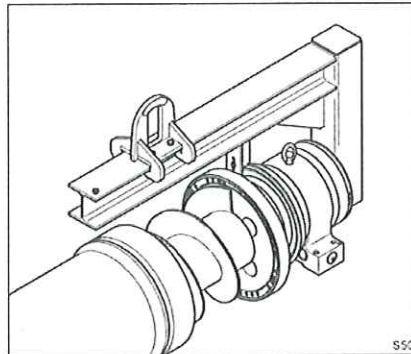

Fig. 35

- Load carrying equipment such as lifting devices for
 - bowl or scroll
 - gear etc.
 may only be used for work routines as described in this manual.
- Do not use damaged or incomplete load carrying equipment.

1.6 Decommissioning, standstill times, storage

The decanter will get damaged if it not operated for a prolonged period and no adequate preserving measures are taken. This likewise applies to the time before commissioning.

When the machine is shut down for longer than 3 months, special measures are required to prevent the machine from getting damaged during standstill.



If these measures are not taken, the roller bearings of the machine on particular will get damaged through corrosion and one-sided loading. This bearing damage results in high consequential costs.

The required preserving measures must be worked out together with Westfalia Separator service. The scope of the required measures depends on the following parameters:

- Duration of the storage / standstill time
- Size and specific equipment configuration of the decanter
- Ambient conditions (temperature, atmospheric humidity etc.)
- Processed product

1.7 Corrosion

Corrosion can also affect bowl parts made of stainless steel. This corrosion can be flat-spread or pit- or crack-shaped and merits special attention.

Corrosion on stainless steel bowl material should be examined thoroughly and documented.

Flat-spread corrosion can usually be measured (reduction of wall thickness)

Pit- or crack-shaped corrosion cannot be measured using non-destructive techniques. At the initial stage pit-shaped corrosion is generally caused by chlorine ions.

Depending on the stressing of the part, pit-shaped corrosion can result in crack-shaped corrosion.

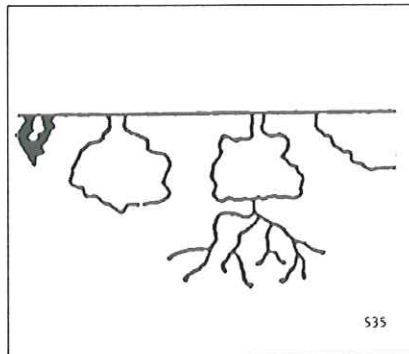

Fig. 36

Possible formation of pit-shaped corrosion.

Such pittings can only be investigated by a materials expert.

In case of crack-shaped corrosion attack with or without superposed flat-spread and pit-shaped corrosion on main bowl components, **the machine must be shut down immediately.** Contact your nearest Westfalia Separator AG representative for a thorough examination.

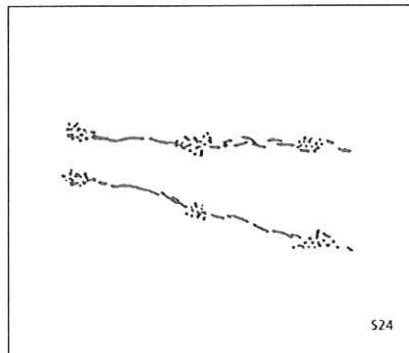

Fig. 37

Pittings

Pittings which are close together or form a linear pattern can signify crack formation beneath the surface. Such pittings should be investigated by a materials expert.

1.8 Erosion

Erosion is caused by solid particles in the process liquid. These solid particles grind marks into the surfaces with which they come into contact.

The following factors favour the occurrence of erosion:

- hard solid particles
- high throughput capacities

The first signs of erosion should be carefully observed and documented. Erosion can deepen rapidly, thereby weakening the bowl material.

Contact your nearest Westfalia Separator representative for a thorough examination. Information on the nature of the damage can be provided by photos, plaster casts or lead molds.

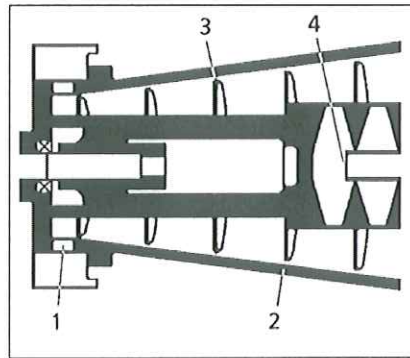

Fig. 38

The surfaces most susceptible to erosion are:

- 1) Solids ejection ports
- 2) Bowl shell
- 3) Scroll flights
- 4) Scroll distributor

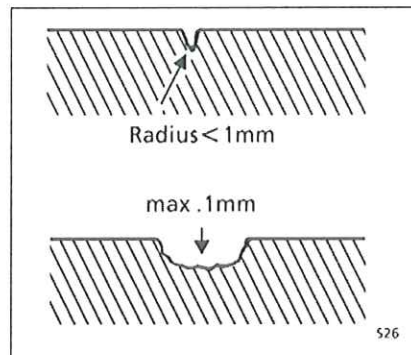

Fig. 39

Signs of erosion which you should immediately report to your nearest Westfalia Separator representative:

- The bottom of the erosion mark has a radius smaller than 1 mm (large notch effect).
- The depth of erosion mark exceeds 1 mm at the deepest point.

2 Machine description

2.1	Main components of the decanter	27
2.1.1	Bowl	27
2.1.2	Housing.....	27
2.1.3	Lubrication	28
2.1.4	Bearing temperature monitoring	28
2.1.5	Drive.....	28
2.1.6	Motor control.....	30
2.2	Cyclo gear.....	30
2.3	Operating principles of the decanter.....	31
2.4	Throughput	31
2.5	Oil lubrication	33
2.5.1	Connections.....	35
2.6	Motor data.....	36

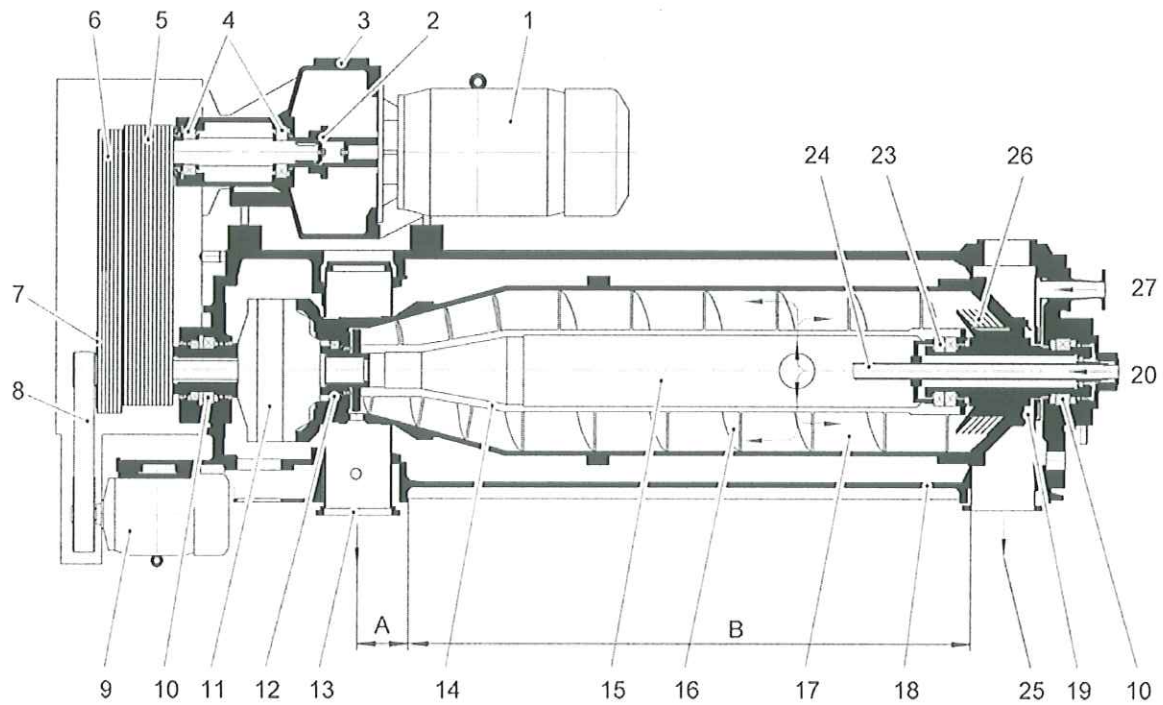

Schema_PA756-00-32

Fig. 40

A Drying zone
B Clarifying zone

- 1 Drive motor
- 2 Clutch
- 3 Clutch housing
- 4 Drive bearing
- 5 Bowl drive
- 6 Scroll drive
- 7 Secondary gear
- 8 Variable speed drive
- 9 Secondary motor (variable)
- 10 Bowl bearings
- 11 Primary gear
- 12 Scroll bearings
- 13 Solids discharge
- 14 Solid-wall bowl
- 15 Distributor
- 16 Scroll
- 17 Separation chamber
- 18 Housing
- 19 Regulating ring
- 20 Feed
- 23 Scroll bearings
- 24 feed tube
- 25 Gravity discharge of the clarified liquid
- 26 Disk stack
- 27 Flush connection for disk stack

2.1 Main components of the decanter

Description of the constructional features of the main decanter components.

2.1.1 Bowl

The bowl is of cylindrical-conical design. Clarification and separation of the liquid phases takes place in the cylindrical section of the bowl, dewatering of the separated solids takes place in the conical section of the bowl.

Axially arranged grooves in the bowl shell enhance trouble-free conveyance of the solids.

Existing or possible wear and corrosion protection:

- All bowl and scroll parts coming in contact with the product are made of CrNiMo steel.
- Exchangeable wearing bushes in the solids ejection ports of the bowl (hard-metal on special request).
- Hard-faced scroll flights for products with erosive properties (on special request).

The clarifying and dewatering efficiency can be changed and hence adapted to the respective process. The following possibilities are available:

- Exchanging the regulating ring. This produces the following tendency:
 - Large inner diameter of the regulating ring produces a long dewatering zone (= good dewatering efficiency) and a short clarifying zone (= less good clarifying efficiency).
 - Small inner diameter of the regulating ring produces a short dewatering zone (= less good dewatering efficiency) and a long clarifying zone (= good clarifying efficiency).
- Altering the differential speed range by exchanging the belt pulleys. This permits changing the layer thickness and dwell time of the solids in the dewatering zone. Tendency:
 - High differential speeds produce a high residual moisture content with pasty solids.
 - Low differential speeds produce a low residual moisture content but can lead to higher stressing of the scroll drive.

When processing crystalline solids, the opposite results are obtained.

2.1.2 Housing

The bowl is located in a self-supporting, noise-insulated cast iron housing which is clad with CrNiMo sheet steel at those parts coming into contact with the product.

All other parts are coated with a paint resistant to caustic, acid and impacts. Some housing parts are made of solid CrNiMo steel.

Vibration dampers between the decanter housing and the foundation frame largely prevent the transmission of vibrations.

2.1.3 Lubrication

The following components are continuously supplied by an electrically operated oil circulation lubrication system:

- both main bowl bearings
- primary and secondary gear
- the scroll bearing on the solids side
- the intermediate shaft bearings (drive)

The liquid-side scroll bearing is packed with grease. On special request this bearing can be supplied with a relubrication system.

All bearings are sealed.

2.1.4 Bearing temperature monitoring

The temperatures of the main bowl bearings and the transmission house bearings are monitored. A PT 100 temperature feeler is fitted at each bearing point. By this means, mechanical damage is avoided or detected at an early stage.

Excessively high bearing temperatures can have the following causes:

- distortedly mounted roller bearings
- false roller bearings with insufficient bearing play
- insufficient oil

A digital temperature indicating device can be delivered on special order. Its electronic limit contact automatically protects the bearings from overheating.

Factory set limit values

- 100 °C = alarm
- 110 °C = shut-down of decanter

If the bearing temperatures are significantly lower during operation, it is prudent to correct the limit values downwards.

Upwards correction of the limit values is permitted only after prior consultation with Westfalia Separator AG!

2.1.5 Drive

The decanter is equipped with a two-gear drive with

- torque-dependent speed control and
- overload protection (without shear pin), permitting immediate re-start.

The primary motor and clutch are fitted so that they do not transfer vibrations to the decanter housing.

Function

The frequency-controlled drive motor drives the scroll and bowl at different speeds via drive belts and two gears.

Part of the drive power required for the scroll is taken from the frequency-controlled secondary motor.



- Do not under any circumstances manipulate the frequency converter to exceed the permissible bowl speed (see name-plate).
- The machine may only be operated with an independent device for speed limiting.

Fig. 41

If the power consumption of this secondary motor rises above the preset maximum permissible value (due to increasing torque on the scroll) the controller increases the motor speed and hence the differential speed.

The differential speed increase accelerates the removal of the solids from the bowl. Reduction in the solids volume results in corresponding reduction of the torque at the scroll.

Consequently, the controller reacts to the decreasing torque by reducing the speed of the secondary motor.

The basic differential speed (and the control range) depends on the gear and belt transmission (see table of speeds 5.3). The differential speed can be increased by approx. 8.5 min^{-1} above this basic differential speed.

Alternatively, the product feed can be controlled torque-dependently.

If the torque exceeds the preset max. value, the product feed is shut off and the main motor switched off.

The secondary motor remains in operation for a preset time. This usually clears the solids out of the bowl.

Note on electrical connection:



The current consumption of the secondary motor is limited to the rated current. This ensures that the permissible torque for the scroll drive is not exceeded.

The necessary switching operations are carried out by the motor control supplied by us.

2.1.6 Motor control

The motor control unit for monitoring start-up and operation has the following functions:

- Automatic start-up of the drive motor after the prelubrication time has elapsed. The primary drive starts in a star or delta circuit, the secondary drive starts direct on line.
- Automatic pre and post oil circulation for bearing and gear circulation.
- Motor protection of oil cooler.
- Motor protection of gear pump unit.
- Motor protection of the drive motors (PTC thermistor monitoring).
- Bowl and differential speed monitoring and indication during operation.
- Start-up monitoring.
- Interlocking of the feed (solenoid valve or pump) during the start-up phase, so that the decanter cannot be fed with product until the operating speed has been reached.
- Automatic differential speed increase with an excessively high scroll drive torque by increasing the speed of the secondary motor.
- Switching off the drive and shutting off the feed in case of
 - gear overload
 - drop in speed (approx. 100 min⁻¹ below rated speed)
 - too high a bearing temperature
 - malfunctions in the oil supply.
- Indication of the current consumption.
- Indication of the operating hours.
- Supply of flush liquid possible if the gear is overloaded and when the decanter is shut down.

A motor control unit capable of performing these functions can be supplied by Westfalia Separator AG.

2.2 Cyclo gear

The primary gear is a cam gear. Its housing is firmly connected with the bowl and is driven by the primary motor via a set of V-belts. The drive shaft of the primary gear is driven by the driven shaft of the secondary gear.

The secondary gear is likewise a cam gear whose housing is driven by the primary motor. The drive shaft of the secondary gear is driven by the adjustable secondary motor. The control system permits a speed increase during operation. This speed increase raises the scroll speed.

Due to the primary gear it is possible to withstand the high torque, which occurs on the scroll when conveying solids, with a suitably dimensioned belt drive.

2.3 Operating principles of the decanter

The decanter is a horizontally arranged scroll centrifuge with a cylindrico-conical solid-wall bowl for the continuous separation of solids from suspensions.

The process liquid enters the decanter through the centrally arranged feed tube and flows into the inlet chamber of the scroll from where it flows through ports into the separation space of the bowl where it is accelerated to operating speed.

The solids particles settle against the bowl wall in the briefest space of time due to the action of the centrifugal force.

The scroll, rotating at a slightly higher speed than the bowl shell, continuously conveys the centrifugally removed solids to the narrow end of the bowl.

Due to the conical shape of the bowl, the solids are lifted out of the liquid in the dewatering zone and rid of adhering liquid due to the action of the centrifugal force.

The solids are discharged into the catch chamber of the housing at the end of the bowl from where they are ejected by cams screwed on the bowl shell.

The liquid flows between the scroll flights to the cylindrical bowl end.

The light impurities still present in the liquid are centrifugally removed on their path through the clarification zone and conveyed by the scroll to the solids discharge.

The clarified liquid leaves the separation space via an exchangeable regulating ring and flows off under gravity.

2.4 Throughput

The effective throughput capacity of the decanter depends on

- the separability or clarifiability of the product,
- the solids loading in the solids,
- the required residual moisture content in the discharged solids,
- the max. permissible solids content in the clarified liquids.

The machine can be adapted to the conditions and requirements to a large extent.

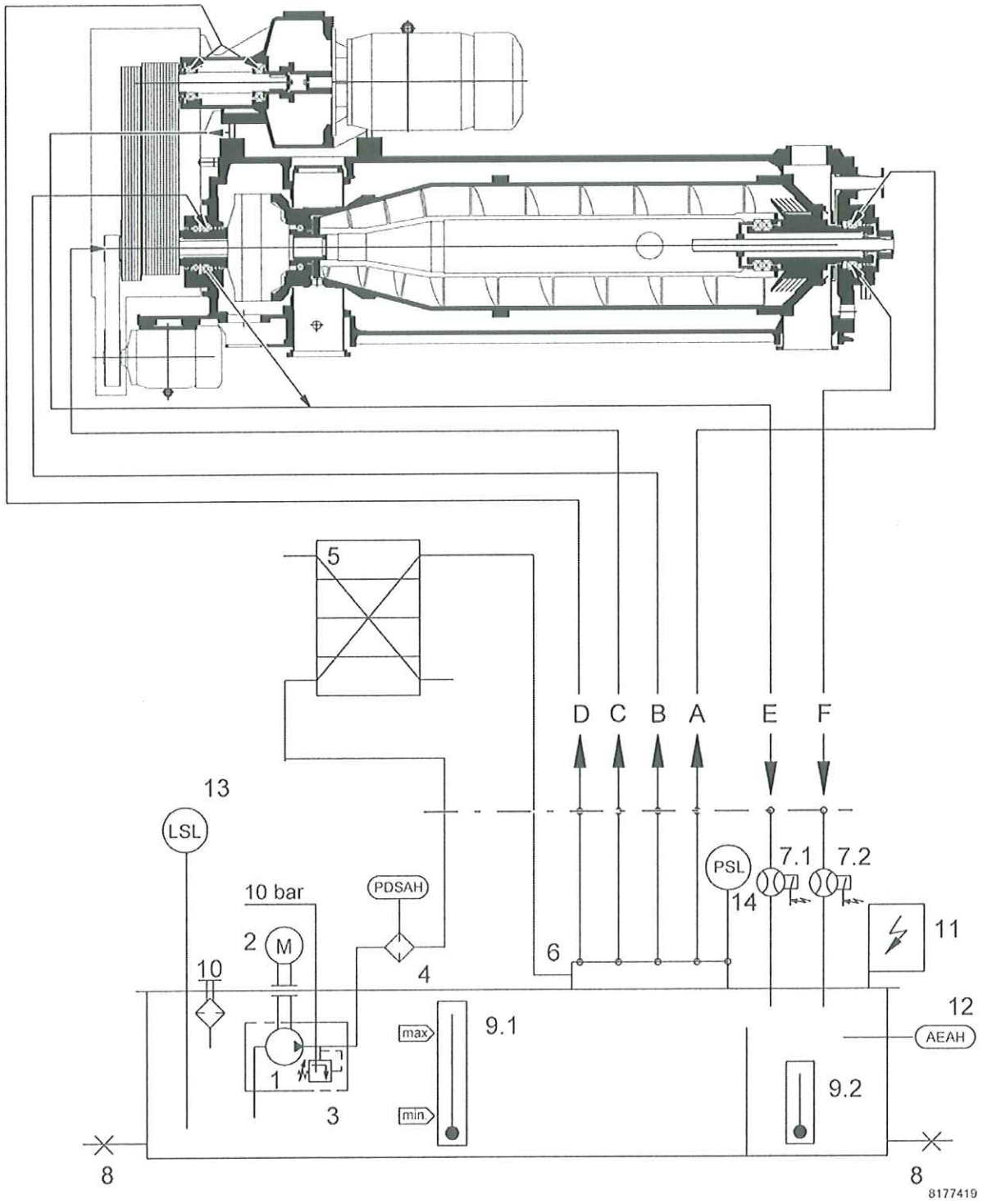

Fig. 42

8177419

2.5 Oil lubrication

The oil circulation lubrication system supplies the following components with lube oil:

- Main bowl bearings
- Drive bearings (transmission house)
- The drive-side scroll bearing
- Gearbox

Pos.	Main components	Function
1	Gear pump	conveys oil
2	Motor	drives gear pump
3	Pressure relief valve	limits the oil pressure to 10 bar
4	Oil filter with electrical feedback to control system	cleans the oil and sends a signal to the control system when the filter is fouled, shuts down the decanter when necessary
5	Heat exchanger	cools oil minimum water volume (at water temperature): – 150 l/h (max. 10°C) – 250 l/h (max. 20°C) – 500 l/h (max. 30°C) Optionally, an air cooler can be supplied. The air cooler is suitable for use up to an ambient temperature of max. 35°C
6	Distributor	distributes oil
7	Flow switches (special request)	monitor oil flows, switch off the decanter drive when necessary
8	Drain screws	drain 8.1 waste oil 8.2 condensate and waste oil
9	Oil level window with thermometer	enables checking of: oil level, oil temperature and condensate water
	9.1 Oil feed	during operation the oil level must be between the min. and max. marks
	9.2 Oil return	
10	Charging and vent filter	filling in / topping up oil, prevents vacuum formation in the system
11	Terminal box	electrical connection
12	Water detector	triggers an alarm when the water content in the oil exceeds the limit value
13	Level monitoring	monitors the oil level switches off the decanter drive when necessary
14	Pressure gauge with oil pressure switch (option)	monitors the oil pressure switches off the decanter drive when necessary

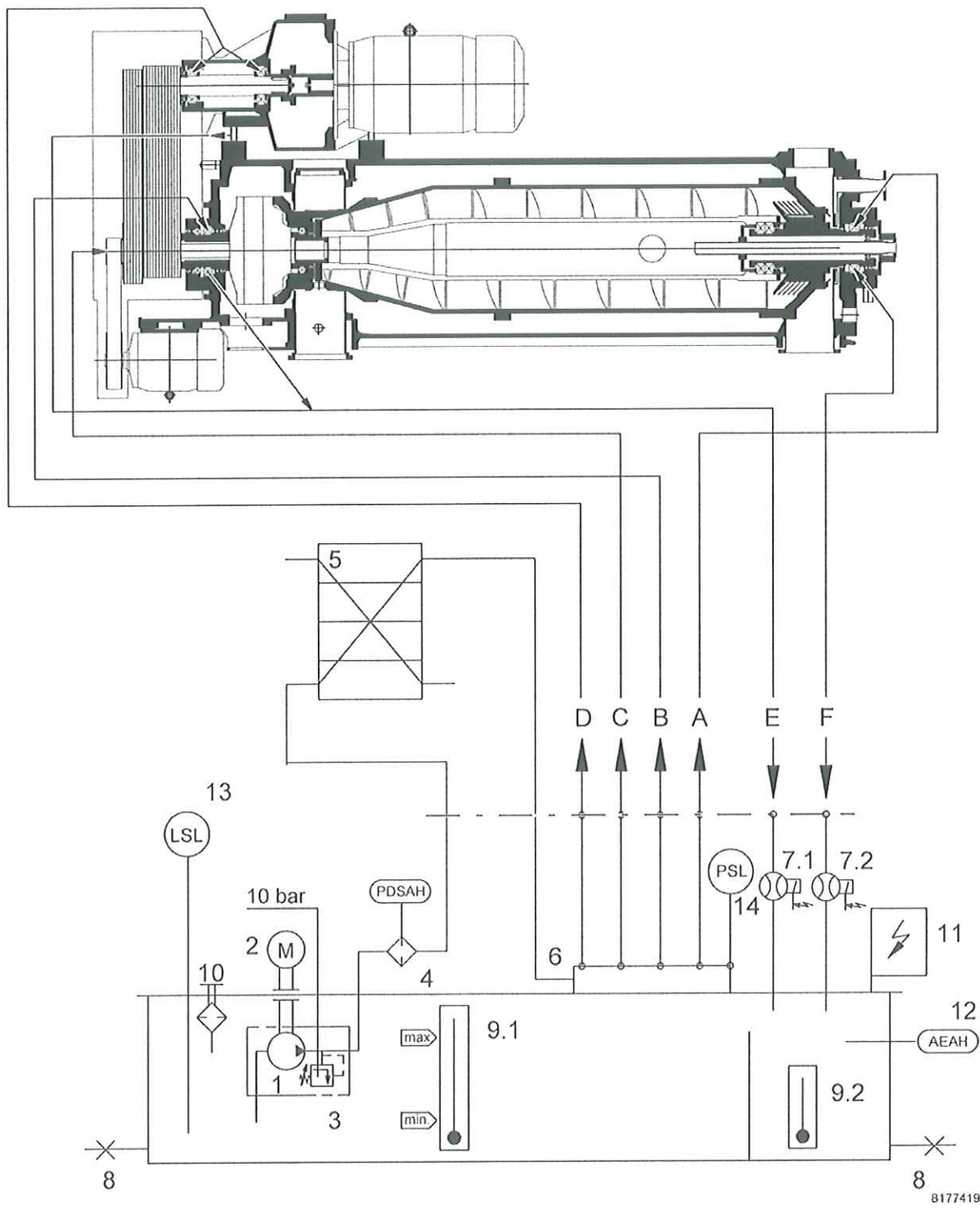

Fig. 43

8177419

2.5.1 Connections

The pressure oil lines and the corresponding connections on the oil unit are marked with the same letters.

The stated oil volumes have been measured at the corresponding bearing points.

Pos.	Main components	Function
A	Pressure oil connection 400 \pm 50 l/h (at 50 Hz) 480 \pm 50 l/h (at 60 Hz)	Main bowl bearing (liquid side)
B	Pressure oil connection 480 \pm 50 l/h (at 50 Hz) 480 \pm 50 l/h (at 60 Hz)	Main bowl bearing (solids side)
C	Pressure oil connection 200 \pm 25 l/h (at 50 Hz) 240 \pm 25 l/h (at 60 Hz)	Gear
D	Pressure oil connection 100 \pm 5 l/h (at 50 Hz) 120 \pm 5 l/h (at 60 Hz)	Drive bearing
E	Oil return	Main bowl bearing (solids side) Drive bearing Gear
F	Oil return	Main bowl bearing (liquid side)

2.6 Motor data

		three phase AC motor of standard design		Motor specifications, as supplied by the customer
		prescribed version		
Manufacturer		Lohar		
Motor version	normal pressure-tight	ANSA-315MB-02C	ANSA-315M-02C	ANSA-315L-B-02C
Serial-No.				
Dimensioned sheet		M116508	M116508	M116508
Test certificate				
Operating voltage				Volt
Frequency				Hz
Motor rating		132	150	kW
Speed	n	3000 min ⁻¹ at 50 Hz	3600 min ⁻¹ at 60 Hz	
Design	normal pressure-tight	IM B5, Terminal box, left hand with cable connectors		
Protection	normal pressure-tight	IP 55		
Kind of starting			Star-delta starting	
Temperature factor	normal pressure-tight	PTC-resistor-type KL150(020)	PTC-resistor-type	PTC-resistor-type KL145(045)
Noise level				
Vibration severity				
Height of motor shaft	h	315	315	315
Shaft end diameter	d	55	65	65
Shaft end length	l	140	140	140
Size of thread	s4	M20	M20	M20
Length of thread	l1	42	42	42
Bearing A-side				
Bearing B-side				
Order-No.	(Bearing A)	0011-6316-360	0011-6316-360	0011-6316-390
	(Bearing B)	0011-6316-360	0011-6316-360	0011-6316-360
Starting time at Y approx.	t	10	10	10
Starting current at Y		1.4	1.2	1.0

Sound-pressure level on measuring surfaces L_A 67.4 dB(A)
 Vibration severity stage "5" (special) according to DIN ISO 2373
 Measuring condition: shaft end with complete fan

This document may not be disclosed to third parties or firms without consent

Fig. 44

		prescribed version
Make		Loher
Motor type		ANGA-200LG-04B
Rating		30 kW at 50 Hz (37 kW at 87 Hz)
Speed	X	2600 min ⁻¹ at 87 Hz
Design	X	IM B8
Enclosure		IP 55
Switching mode	X	Frequency converter
Temperature probes	X	PTC thermistors KL 145 (145°C)
Size DIN 42677		200L
Shaft end diameter	d	55 mm
Shaft end length	l	110 mm
Thread size	s ₄	M 20
Thread length	t ₁	42 mm

Note
Notes
Notizen
Anotaciones
Notizen
Notes
Note

3 Operation

3.1	Operation	40
3.1.1	Start preparations	40
3.1.2	Start-up	40
3.2	Operation	41
3.2.1	Operation with a vibration monitoring system.....	41
3.2.2	Shut-down and ordinary cleaning	42
3.2.3	Flushing the decanter before operation.....	42
3.3	Thorough cleaning	42
3.4	Long-term shut-down.....	43
3.5	Operating faults	44
3.5.1	Start-up problems	44
3.5.2	Bearing temperature too high	44
3.5.3	Vibrations too high	44

3.1 Operation

Instructions for starting and operating the decanter.

3.1.1 Start preparations

Before starting, note and check the following:

- **Note:**
 - "Safety precautions" (chapter 1)
- **Check:**
 - Has the decanter been installed completely and correctly?
 - Is the supervisory equipment complete and functional?
 - Are the product paths ready for operation?
 - Is the oil tank for the oil circulation lubrication filled?
 - Is the hand valve in the cooling water line open?

3.1.2 Start-up

For starting proceed as follows:

- Switch on main switch of motor control. Press decanter start button. First, the circulation lubrication will start. After approx. 10 minutes lubrication, the decanter drive starts automatically. During the start-up phase:
 - Check the direction of rotation. When looked at from the liquid side, the fan of the main motor must rotate clockwise.
- Wait until the start-up time has elapsed (approx. 10 minutes).
- Make sure that the speed stated on the nameplate of the decanter is reached within the specified time and maintained during operation.
- Switch on auxiliary equipment, e.g.
 - Metering pump for flocculent,
 - Conveying equipment for liquid and solids (screw conveyors, conveyor belts etc.)The auxiliary equipment must be electrically interlocked with the decanter so that these units are already running when the decanter starts. The product feed should be shut off if one of these units fails.
- Open the product feed and adjust the desired throughput capacity.

Note: A renewed start-up is not possible unless the bowl speed has not dropped by more than 150 min^{-1} or is less than 50 min^{-1} .

3.2 Operation

The machine is largely monitored by the decanter control unit.

Provision should be made to ensure that in the event of a malfunction (power failure, overloading of the gear etc.) the product feed is shut off and the flush-water line is opened automatically.

Work to be carried out regularly:

- Adhere to the "Lubrication and maintenance schedule"!
- Repairing the scroll
If the decanter operating efficiency is impaired due to
 - frequent speed increases of the secondary drive or
 - increased residual moisture content of the discharged solids, the scroll must be checked for wear (gauge will be supplied on special request). If the wear is extensive, the scroll must be repaired or replaced.
- Checking for wear
If the erosive properties of the feed product are unknown, we recommend a wear check every 500 operating hours, concentrating particularly on the
 - scroll,
 - cams in the solids discharge (if fitted),
 - catch chamber.
- Inspection
We recommend having your decanter inspected by our specialists at regular intervals. These inspections help to
 - maintain the operating reliability of the decanter and
 - to avoid unwanted downtime.

General note: A deterioration in the operating efficiency of the decanter can also be caused by a change in the feed product.

3.2.1 Operation with a vibration monitoring system

On special request, the decanter can be equipped with a vibration monitoring system.

This system determines the effective vibration velocity (RMS as per ISO 2372), thereby ensuring objective monitoring of the vibration behaviour of the decanter.

The table below shows the evaluation of the determined vibration characteristics.

Effective vibration velocity (RMS)		Evaluation as per ISO 2372
0 – 7	mm/s	good
7 – 18	mm/s	acceptable
18 – 20	mm/s	still acceptable
above 20	mm/s	not acceptable

Thus the limit values to be adjusted for the vibration monitoring unit are as follows:

- Limit value 1 (preliminary alarm): 18 mm/s
(corresponds to 90% with max. measuring range of 20 mm/s)
- Limit value 2 (feed "closed", drive "off"): 20 mm/s
(corresponds to 100% with max. measuring range of 20 mm/s)

3.2.2 Shut-down and ordinary cleaning

For shutting down with ordinary cleaning, proceed as follows:

- Close the product feed line and switch off the metering pump for flocculent (if installed).
- Flush the bowl.
 - Close the product feed.
 - Feed at least 25m³/h flush water into the machine.
 - Feed flush water into the machine until no more solids discharge. During this process, flush water discharges at the solids side.
 - Reduce the bowl speed to 1400 min⁻¹ via the frequency converter of the main motor. Maintain this speed for at least two minutes with open flush water valve.
 - Reduce the bowl speed to 100 min⁻¹.
 - Switch over from flush water to cleaning lye.
 - Flush with at least 15m³/h cleaning lye for a period of minimum 20 minutes.
- Flush the disk stack.
 - Close the flush water valve for decanter feed.
 - Increase the bowl speed to 1000 min⁻¹.
 - Open valve for flushing the disk stack.
 - Flush with at least 35m³/h cleaning lye for a period of 60 minutes.
 - Switch over from cleaning lye to flush water.
 - Flush for at least 5 minutes.
 - Close valve for flushing the disk stack.
 - Raise bowl speed to the maximum for 10 minutes.
 - Reduce the bowl speed to 600 min⁻¹.
 - Flush the disk stack again with 35m³/h flush water for 5 minutes.
 - Shut down the decanter.

3.2.3 Flushing the decanter before operation



Only when the vibration alarm triggers when running up the decanter.

- Bowl speed 100 min⁻¹.
- Flush with at least 15m³/h cleaning lye for a period of 30 minutes.
- Close the flush valve.
- Run up the decanter to maximum speed.



If the vibration alarm triggers again when running up the decanter, repeat the flushing procedure!

3.3 Thorough cleaning

Thorough cleaning should be carried out to avoid infection as well as prior to long-term shut-downs.

- Clean the decanter as described in chapter 3.2.2
- Remove scroll, see 4.7.2.

- Thoroughly clean the bowl and scroll with brushes using water or a suitable caustic solution.
- Dismantle the disk stack and clean the disks thoroughly with a suitable caustic and brush.
- Clean the solids discharge through the drain hole at the bottom and the cleaning hole at the top.

3.4 Long-term shut-down

When the machine is shut down for a lengthy period and there is a risk of frost:

- Carry out thorough cleaning, see above.
- Drain water from the lines and filters.

When the machine is shut down for exceptionally long periods (e.g. seasonal operation):

- Drain the lube oil and fill the oil tank with a slushing oil up to the middle of the sight glass. Suitable slushing oils are:
 - SHELL Enisis motor oil 30
 - Mobilarma 524 SAE30
- Coat all lubricating points with slushing oil. Briefly start the decanter as follows:
 - Press "decanter start" button.
 - Wait for the prelubrication time to elapse (approx. 10 minutes).
 - Stop the decanter run-up at 500 min⁻¹. Higher speeds damage the roller bearings because of inadequate lubrication.



Repeat the start procedure every 3 months.

- Slacken the drive belts.
- Arrest the bowl.
- Drain the slushing oil at the beginning of the next season and fill in lube oil again. Be sure to pay attention to the following:
 - Drain the slushing oil completely from the oil circuit and from the lines, oil coolers and gearboxes. Slushing oil residues may otherwise lead to foaming in the oil during operation.
 - Use only the lube oil specified in the "Lubrication and maintenance schedule"



Note :

There is no need to fill in slushing oil when the decanter is started once a month. The following work must be carried out between the monthly starts:

- Arrest the bowl to take the strain off the main bowl bearings.
- Slacken the drive belts to take the strain off the motor bearings and to go gentle on the belts.

3.5 Operating faults	Possible cause	Remedy
3.5.1 Start-up problems	Gap constriction due to possible solids deposits between bowl and collector	Clean gaps
3.5.2 Bearing temperature too high	Insufficient lubricant Onsetting bearing damage	Check lubricating system Replace roller bearings
3.5.3 Vibrations too high	One-sided product deposits	Check scroll and clean if necessary

4 Maintenance

4.1	Avoiding accidents.....	46
4.2	Lubrication and maintenance schedule	47
4.3	Demands relating to service personnel and spare parts	47
4.4	Service and maintenance contract with Westfalia Separator	47
4.5	Instructions on handling roller bearings.....	48
4.6	Screw tightening torques	49
4.6.1	Screw tightening torques in inch-pound (inlb)	50
4.7	Scroll.....	51
4.7.1	Permissible wear to scroll	51
4.7.2	Removing the scroll	52
4.7.3	Replacing the scroll	53
4.7.4	Fitting the scroll.....	56
4.8	Bowl	58
4.8.1	Removing the bowl	58
4.8.2	Fitting the bowl.....	60
4.8.3	Replacing the wearing bushes	61
4.9	Replacing the scroll bearings	62
4.9.1	Scroll bearing - liquid side.....	62
4.9.2	Removing the scroll bearings (solids side).....	66
4.9.3	Fitting the scroll bearings (solids side)	67
4.10	Replacing the main bowl bearings.....	70
4.10.1	Removing the main bowl bearings (liquid side).....	70
4.10.2	Fitting the main bowl bearings (liquid side)	72
4.10.3	Removing the main bowl bearing (solids side).....	76
4.10.1	Fitting the main bowl bearings (solids side).....	78
4.11	Drive belts.....	80
4.11.1	Drive belts (primary drive).....	80
4.11.2	Drive belts (secondary drive).....	82
4.12	Bearing change - oil feed.....	83
4.12.1	Bearing change — drive (transmission house).....	84
4.13	Oil circulation lubrication system	90
4.14	Cyclo gear.....	91
4.14.1	Dismantling the secondary gear	91
4.14.2	Assembling the secondary gear	92
4.14.3	Primary gear	92
4.15	Gaskets.....	93
4.15.1	Radial sealing rings	93
4.15.2	Important mounting instructions for Elrings	94
4.16	Motor bearings.....	94

4.1 Avoiding accidents

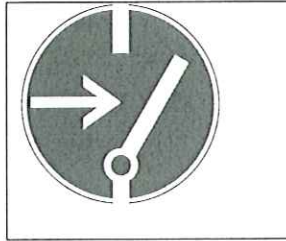

Fig. 45

Before all maintenance and servicing:

- Observe the safety precautions in chapter 1.
- Perform a controlled shut-down of the decanter via "decanter off".
- Switch off all electrical apparatus via the main switch.
- Secure the installation against unintended re-starting with locking devices.

Why is it not sufficient to switch of the machine via "Emergency-Off"?

- "Emergency-Off" only immediately disconnects the power to the main drive motor.
- Systems and components required to safely bring the complete machine to a standstill still carry current. The secondary drive, oil circulation lubrication system or actuators can suddenly start without warning.

What happens in the event of a voltage cutoff during operation?

- A voltage cutoff during operation automatically triggers an "Emergency-Off" circuit.
- The secondary drive, oil circulation lubrication system or actuators can suddenly start without warning when the power returns.



Fig. 46

Important: Danger to life through high-speed rotating machine parts !

- Do not loosen any part of the machine before the decanter bowl has come to a standstill. The run-down time of the decanter bowl is approx. 20 minutes.



Fig. 47

Important: Danger of injury due to hot surfaces.

- Do not start maintenance work until all machine parts have adequately cooled down. This can take as long as two hours depending on the processed product and machine size.

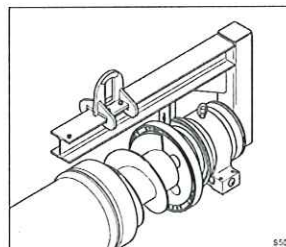

Fig. 48

Important: Danger of injury through falling machine parts.

- Load carrying equipment such as lifting devices for
 - bowl or scroll
 - gear etc.
 may only be used for work routines as described in this manual.
- Do not use damaged or incomplete load carrying equipment.

4.2 Lubrication and maintenance schedule

A project-related lubrication and maintenance schedule, though a separate document, is part of the machine documentation.

The lubrication and maintenance schedule gives the following information:

- all maintenance work to be performed at regular intervals
- maintenance intervals
- lubricants to be used

4.3 Demands relating to service personnel and spare parts



Fig. 49

- Use only genuine spare parts from Westfalia Separator. The use of non-genuine parts leads to:
 - Safety risks
 - Lower durability and availability
 - Increased maintenance requirementIf a safety risk arises, this may have legal consequences for the responsible persons. In this case, Westfalia Separator shall assume no liability or warranty.

- Deploy only well trained personnel for maintenance work, e.g. the service personnel from Westfalia Separator or personnel trained by Westfalia Separator. An incorrectly maintained/assembled machine poses a safety risk for the operators.

4.4 Service and maintenance contract with Westfalia Separator

When a service and maintenance contract is concluded with Westfalia Separator, the maintenance work is optimally adapted to the production process. This can substantially lower maintenance costs.

4.5 Instructions on handling roller bearings

Roller bearings must be kept in their original packing; the packing may only be opened at the workplace and directly prior to fitting. Otherwise there is a risk that the bearings will become soiled and rust.

Before packing the roller bearings are immersed in slushing oil. This corrosion protection must be removed prior to fitting using a suitable cleaning agent.



Danger due to toxic and easily combustible liquids !

Suitable cleaning agents are: alcohol (spirit), benzene, acetone and alkaline cleaning agents suitable for grease removal. Be sure to observe the safety and handling instructions of the cleaning agent manufacturer.

Cleanness during assembly

Roller bearings must under all circumstances be protected from dirt and moisture as even the finest particles which enter the bearing will damage the bearing surfaces.

The assembly site must therefore be free from dust and dry. It may not, for example, be in the vicinity of grinding machines. The use of compressed air must be avoided.

Also pay attention to the cleanness of the shaft and the housing as well as all other parts.

Premature wear to bearings

If a roller bearing fails prematurely, this can have the following reasons:

- Local damage to the races; e.g., score marks, scratches or dents.
Such damage occurs, for example, when the outer ring of a cylindrical roller bearing is mounted twisted with the roll barrels over the inner ring or when the pressing force is guided via the roll barrels.
- Insufficient lubricant
- Incorrect lubricant
- Lubricant change intervals too long

Damage becomes evident in the short-term by an increased running noise level. In the long-term it results in premature fatigue of the bearing surfaces.

4.6 Screw tightening torques

The torques apply to:

- metric screws with coarse-pitch thread.
 - hex head screws according to DIN EN ISO 4014
 - Allen screws according to DIN EN ISO 4762
- through holes according to DIN ISO 20273 (medium).
- greased screws (coefficient of friction = 0.10).
- torque wrench with a scatter (tolerance) of $\pm 10\%$.
- the material combination steel - steel or stainless steel.



Screws whose torque deviates from this table are marked with the required torque in the manual.

Extract from the works standard WSN 19-0019-00						
Property class		8.8	10.9	12.9	A2-70 A4-70	
Yield strength/ proof stress [N/mm ²]		640/ 660	940	1100	450/ 250	
Pitch	Thread size	Torques [Nm]				
0,70	M 4	2,6	3,9	4,5	1,9	M 4
0,80	M 5	5,2	7,6	8,9	3,6	M 5
1,00	M 6	9,0	13,2	15,4	6,3	M 6
1,25	M 8	21,6	31,8	37,2	15,2	M 8
1,50	M 10	43,0	63,0	73,0	30,0	M 10
1,75	M 12	73,0	108,0	126,0	52,0	M 12
2,00	M 16	180,0	264,0	309,0	126,0	M 16
2,50	M 20	363,0	517,0	605,0	248,0	M 20
3,00	M 24	625,0	890,0	1041,0	237,0	M 24
3,50	M 30	1246,0	1795,0	2077,0	472,0	M 30
4,00	M 36	2164,0	3082,0	3607,0	-	M 36

4.6.1 Screw tightening torques in inch-pound (inlb)

The following formula is used to convert the torques (M_a) from "Nm" to "inlb":

$$Ma_{inlb} = Ma_{Nm} \times 8,85$$

Example:

Ma_{inlb} = Wanted (screw tightening torques in "inch-pound")

Ma_{Nm} = 50 (screw tightening torques in "Newtonmeter")

$Ma_{inlb} = 50 \text{ Nm} \times 8,85$

$Ma_{inlb} = \underline{\underline{442,5 \text{ inlb}}}$

Extract from the works standard WSN 19-0019-00						
Property class		8.8	10.9	12.9	A2-70 A4-70	
Yield strength/ proof stress [N/mm ²]		640/ 660	940	1100	450/ 250	
Pitch	Thread size	Torques [inlb]				
0,70	M 4	23,0	34,5	39,8	16,8	M 4
0,80	M 5	46,0	67,3	78,8	31,9	M 5
1,00	M 6	79,7	116,8	136,3	55,8	M 6
1,25	M 8	191,2	281,5	329,3	134,5	M 8
1,50	M 10	380,6	557,6	646,1	265,5	M 10
1,75	M 12	646,1	955,9	1115,2	460,3	M 12
2,00	M 16	1593,2	2336,7	2735,0	1115,2	M 16
2,50	M 20	3212,9	4576,0	5354,9	2195,0	M 20
3,00	M 24	5531,9	7877,4	9213,9	2097,7	M 24
3,50	M 30	11028,3	15887,5	18383,5	4177,7	M 30
4,00	M 36	19153,6	27278,8	31925,6	-	M 36

4.7 Scroll

The scroll must be checked for wear at regular intervals. The maintenance intervals are specified in the "Lubrication and maintenance schedule" (4.2).

In case of extensive wear to the scroll flights, the operating efficiency of the decanter is impaired. This is indicated by

- high moisture content of the discharged solids
- permanently increased differential speed (analog control) or frequent increases in differential speed (digital control)

4.7.1 Permissible wear to scroll

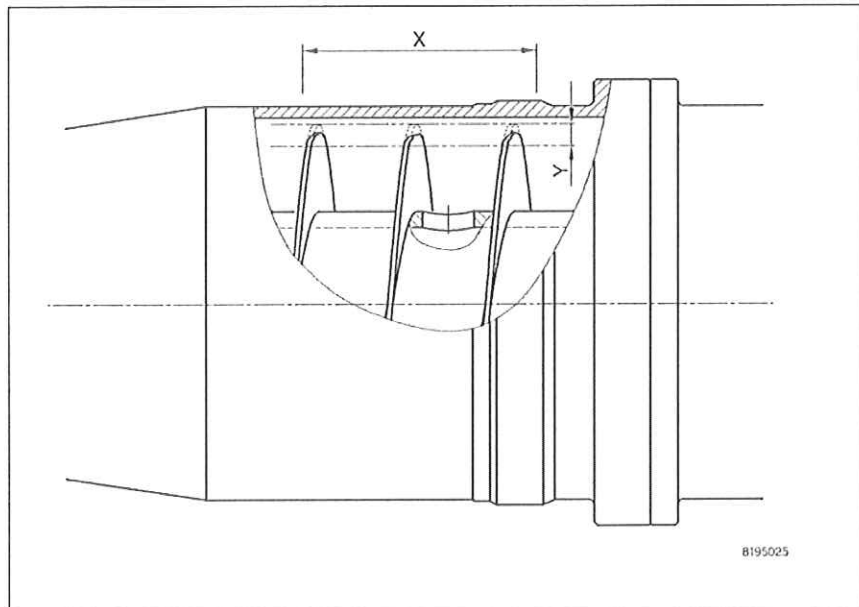

Fig. 50

As a rule, 2 - 3 flights in the product inlet zone («X») are particularly affected.

In this area, a wear of approx. 20 mm («Y») on one side should be tolerated, so that the remaining hard facing is also worn down to a large extent.

The extensive wear in the product inlet zone does not cause significant additional repair costs.

In addition to the wear on the scroll flights, the distributors should also be checked.

4.7.2 Removing the scroll

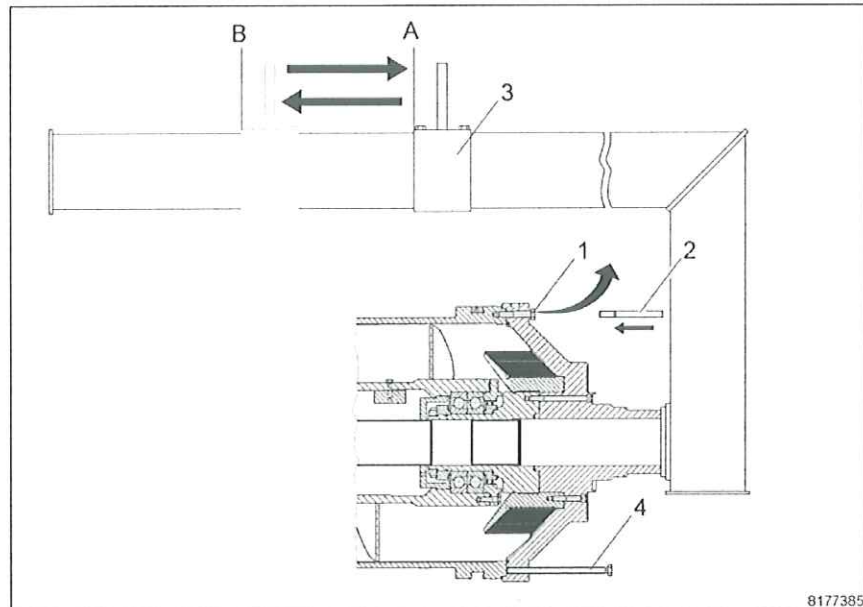

Fig. 51



Do not loosen any part of the machine before the decanter bowl has come to a standstill.

- Always use complete tools and use them only for the intended application, see "Set of tools".
- Remove the regulating ring, see 5.2.4.
- Unscrew screws 1 from the bowl shell and screw in 2 threaded spindles 2 as a guide.
- Bring the lug 3 of the lifting device into position "A". Hang the lifting device into the hoist and slide it into the bearing hub as far as it will go.
- Bring lug 3 into pos. "B". Raise the hoist slightly. Align lug 3 until the hoist is horizontal.
- Force scroll (with bearing hub) out of the bowl using puller screws 4.



- Carefully withdraw the scroll from the bowl.
The lifting device must be absolutely level (if necessary, correct its position by displacing the lug).
- Place the scroll with bearing hub on a suitable assembly bench and secure to prevent it from slipping. Leave the lifting device in mounted position.

4.7.3 Replacing the scroll

Removal

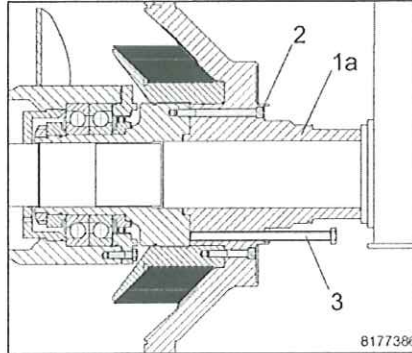

Fig. 52

Undo Allen screws 2.
Screw in 4 puller screws M16 (pos. 3) and evenly force off bearing hub part 1a.

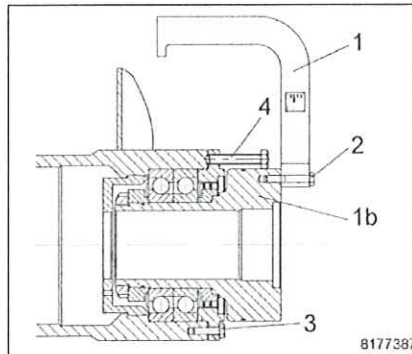

Fig. 53

Loosen hex head screws 3.
Mount lifting device 1 with screw M 16/8.8 (pos. 2) to bearing hub part 1b.
Screw in puller screws 4 and pull the complete bearing assembly evenly out of the scroll body.

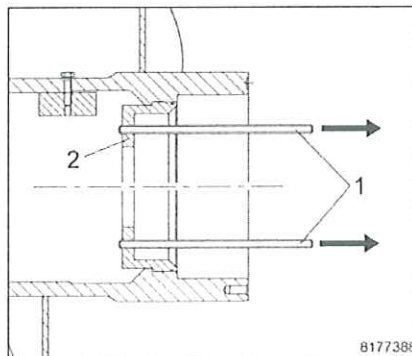

Fig. 54

Screw two threaded rods M12 into the remaining bearing cover 2. Pull bearing cover 2 evenly out of the scroll body.

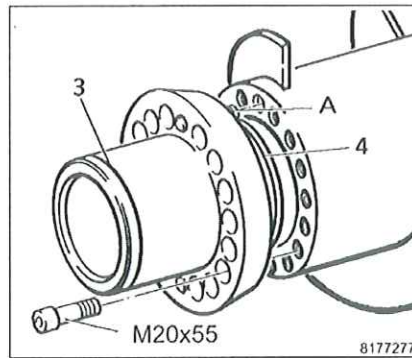

Fig. 55

Unscrew Allen screws M20x55 out of the driver.
 Unscrew two threaded pins (holes can be used for puller screws).
 Force off the driver.

Fitting

Assembly is carried out in reverse order. Note the following:

Clean all parts carefully. Replace worn or damaged parts immediately. Wear to the scroll flights is permissible to a certain extent, see 4.7.1 .

To ensure perfect running of the bowl, all plane surfaces and centering rims must be smooth and clean.

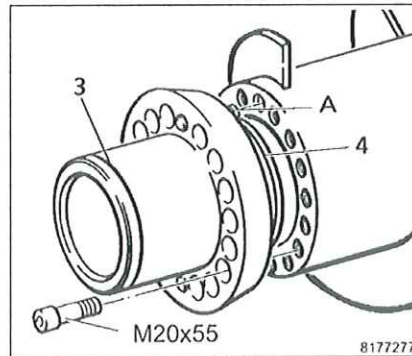

Fig. 56

When fitting the replacement scroll, note the following:
 Check seat and condition of gaskets 3 and 4. Replace if necessary.
 Tighten 16 cylindrical screws M20x55 evenly and crosswise.
 Required screw quality: ISO 4762, 1.4571, A4-70
 Required torque (greased screws): 180 Nm
 Seal puller thread with threaded pins.

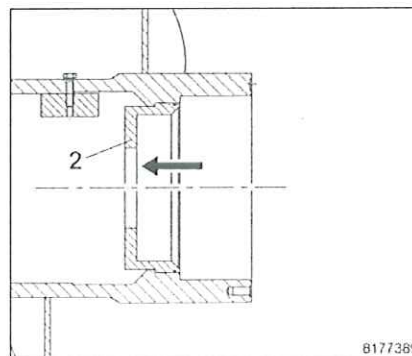

Fig. 57

Slide bearing cover 2 into the scroll body as far as it will go.

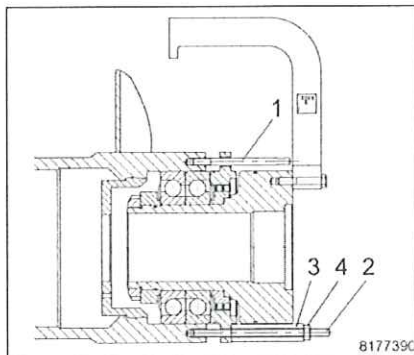

Fig. 58

Screw two guide rods M16 (pos. 1) into the scroll body.

Use the lifting device to carefully slide the pre-assembled bearing assembly over the guide rods into the scroll body.

Screw in two threaded rods M16 (set of tools). Pull the bearing assembly with hexagon nuts 4 and sleeves 3 into the scroll body.

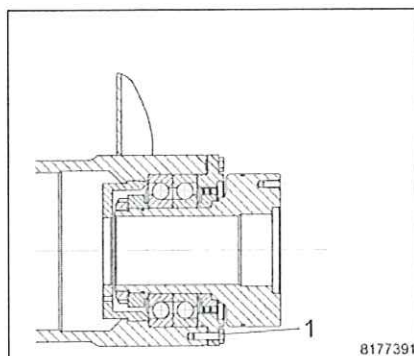

Fig. 59

Remove the lifting device.

Tighten the bearing assembly evenly and crosswise with the aid of 14 hex head screws M16x55 (pos. 1). Rotate the bearing hub if necessary.

Note:

Required screw quality: ISO 4014, 1.4571, A4-70

When correctly assembled, the gap »S« between scroll and bearing cover is 0.4-1.4 mm.



The parts of the bearing hub can be mounted in one position only.

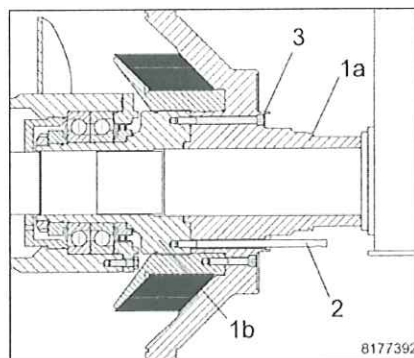

Fig. 60

Pull bearing hub part 1a with the lifting device over two guide rods M16 (pos. 2) on to the bearing hub.

Bolt tight the bearing hub crosswise using Allen screws M16x180 (pos. 3).

Note:

Required screw quality: ISO 4014, 1.4571, A4-70

4.7.4 Fitting the scroll

Assembly is carried out in reverse order. Note the following:

- Clean all parts carefully. Replace worn or damaged parts immediately.
- To ensure perfect running of the bowl, all plane surfaces and centering rims must be smooth and clean.

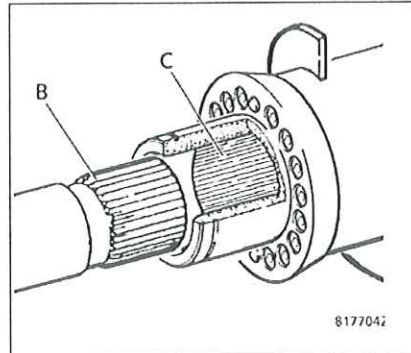

Fig. 61

- Grease driver C on the outside with Molykote (Part-No. 0015-0104-020) to prevent fretting corrosion.

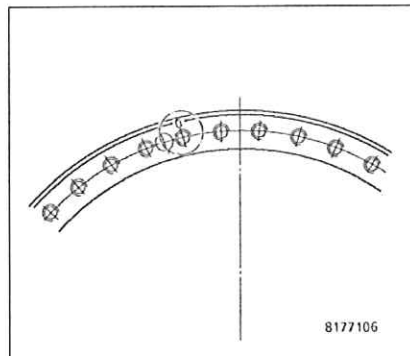

Fig. 62

- Screw one threaded spindle through the taphole at the level of the "O" mark into the bowl shell. Screw in the second threaded spindle opposite.
- Rotate the bearing hub until the "O" marks on the bearing hub and bowl shell are aligned. Since the "O" mark on the bowl shell is concealed, the screwed in threaded spindle serves as orientation.

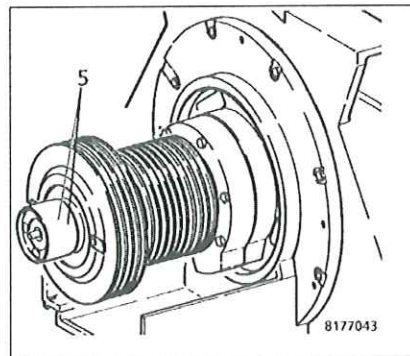

Fig. 63

- Introduce the scroll together with the bearing hub into the bowl. Pay attention to the correct position of the tothing (driver) and gear shaft. If necessary, the position can be corrected by rotating the flat belt pulley 5 of the secondary gear. (17.5 revolutions of the flat belt pulley move the driven shaft by one tooth).

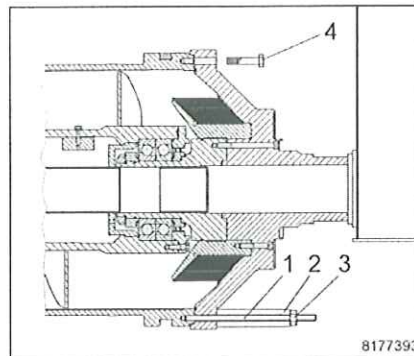

Fig. 64

- Screw in 2 threaded rods M20 (pos. 1) with sleeves 2 and nuts 3.
- Use the nuts 3 to press the scroll all the way into the bowl. Leave the lifting device in lifting position until the bearing hub fits closely.
- Fasten the scroll with 45 hex head screws M20x100 (pos. 4).
Required screw quality: ISO 4014, 1.4571, A4-70
Required torque (greased screws): 215 Nm.

4.8 Bowl

Check the bowl for wear at regular intervals. The inspection intervals are given in the "Lubrication and maintenance schedule". Pay special attention to the following:

- The longitudinal grooves in the conical area must still be visible
- Mechanical damage
- Wearing bushes in the solids ejection ports

4.8.1 Removing the bowl



Do not loosen any part of the machine before the decanter bowl has come to a standstill.

- Always use complete tools and use them only for the intended application, see "Set of tools".
- Only use suitable hoists and load-carrying equipment.

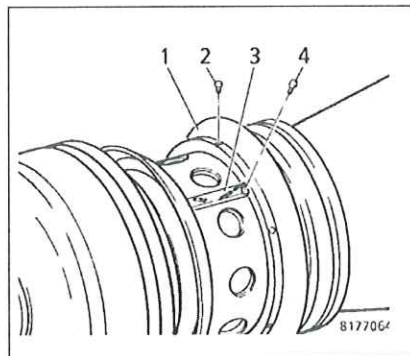

Fig. 65

- Remove catch chamber cover.
- Unscrew Allen screws 4 and remove cams 3.
- Loosen hex head screws 2. Slide protective ring 1 over the solids ejection ports.
- Remove scroll with bearing hub, see 4.7.2.
- Remove scroll bearings on the solids side, see 4.9.2.

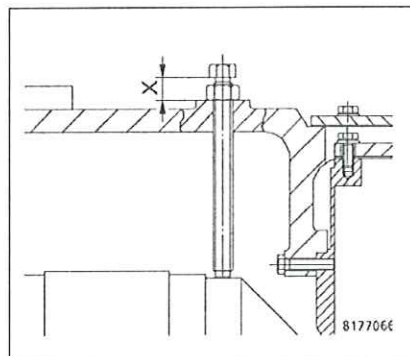

Fig. 66

- Pull all bowl lock screws lightly against the bowl shell.
- Measure and note dimensions "X". The dimensions are required for re-fitting the bowl.
- Loosen bowl lock screws on the solids side.

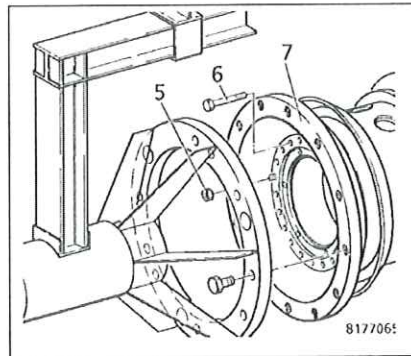

Fig. 67

- Remove hex head screws 6 and hexagon nuts 5.
- Attach lifting device to flange 7.

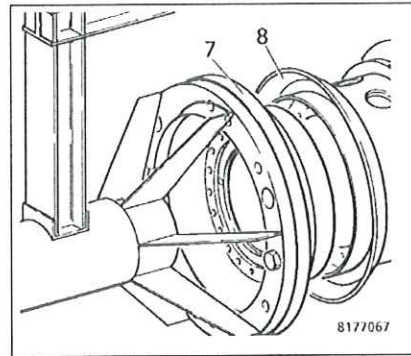

Fig. 68

- Force off flange 7 (4xM12).

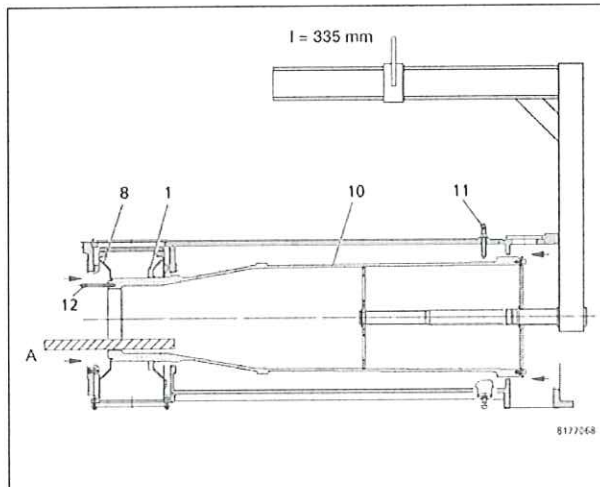

Fig. 69

- Remove bowl shell from the housing. To do this:
 - Loosen lock screws (4xM20) on the liquid side.
 - Introduce wooden beam A into the bowl in such a way that protective rings 8 and 1 (each 19 kg) are caught and do not fall into the solids chute.
 - Suspend lifting device in the hoist and attach to the bowl shell (5xM20).
 - Carefully withdraw the bowl shell from the housing.

4.8.2 Fitting the bowl

Carefully clean all parts. Replace worn or damaged parts immediately.

- When installing a new bowl, the stud bolts 12 must be taken from the old bowl and fitted in exactly the same way.
- Introduce the bowl shell into the housing using the lifting device (l = 335) and note the following:
 - Protective rings 8 and 1 must be fitted when introduced into the catch chamber. They cannot be fitted later. Do not yet secure protective rings.
 - Introduce bowl shell into the housing as far as it will go.

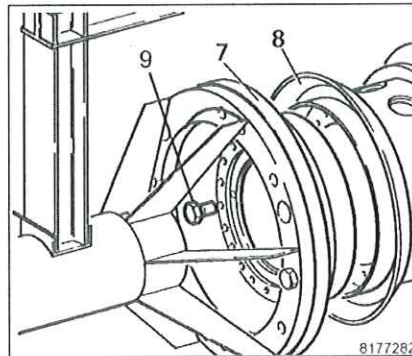

Fig. 70

- Use the lifting device to introduce the flange 7 into the housing on the solids side.
- Fasten flange 7 to the bowl shell with 26 hex head screws M20x130. Required screw quality: ISO 4014, 8.8. Use the power assist tool; required torque (greased screws): 310 Nm

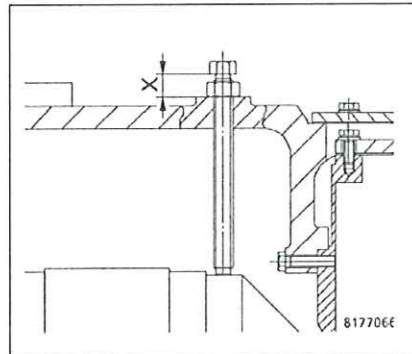

Fig. 71

- Screw in the lock screws until the dimension measured during removal has been attained.
- Fit scroll with bearing hub, see 4.7.4.
- Fit the scroll bearings on the solids side, see 4.9.2.
- When the bowl can be rotated again, screw tight protective rings and cams.

- When installing the bearing housing on the solids side, the position of the bowl in the housing may have to be corrected with the lower lock screws to prevent constraining forces from acting on the main bowl bearing.

4.8.3 Replacing the wearing bushes

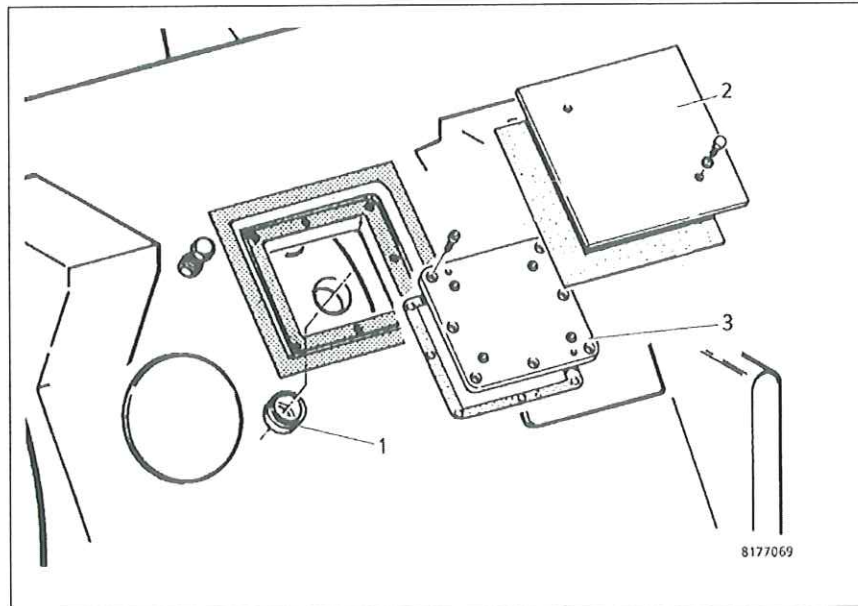

Fig. 72

Removal



Do not loosen any part before the bowl has come to a standstill.

- Unscrew catch chamber cover from the catch chamber. Only undo the screws at the outer edge of the cover; the inner screws serve to hold the wear liners on the cover.
- Drive the wearing bushes out of the solids ejection ports into the inside of the bowl using a mandrel until all the wearing bushes are in the bowl.
- Remove scroll, see 4.7.2. New wearing bushes can only be fitted from the inside.

Fitting

- Carefully clean all parts. Replace worn or damaged parts immediately.
- Ensure that diametrically opposite wearing bushes weigh the same. When ordering spare parts, bearing bushes are supplied in pairs of the same weight.
- De-grease new wearing bushes and glue them in place with a suitable adhesive (e.g. Loctite 275).
- Fit scroll, see 4.7.4.

4.9 Replacing the scroll bearings

The scroll is supported by two angular contact ball bearings on the liquid side and by a grooved ball bearing on the solids side. When replacing them, note the following:

- The roller bearings on the liquid and solids side must always be replaced together.
- Always use complete tools and use them only for the intended application, see "Set of tools".
- Only use suitable hoists and load-carrying equipment.
- Roller bearings with special tolerances are required for all bearing points. Use only those roller bearings specified in the parts list.
 - Roller bearings can be inductively heated to facilitate assembly but not above 90 °C.
 - In order not to damage the roller bearings during fitting, always use the mounting devices supplied in the "Set of tools".
 - If no special mounting tool is available for a roller bearing, a plastic or aluminium mandrel can be used.
- The radial packing rings for sealing off the scroll bearings are marked with an "S" on the liquid side. See also section 4.15.1.

4.9.1 Scroll bearing - liquid side

Removal



Do not loosen any part of the machine before the decanter bowl has come to a standstill.

- Remove scroll, see 4.7.2 and 4.7.3 .

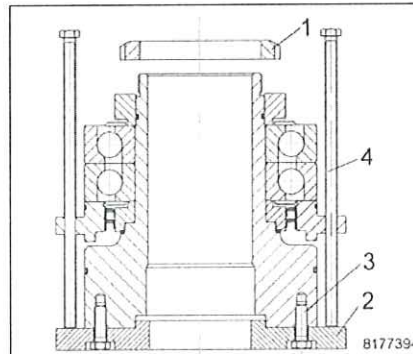

Fig. 73

- Screw plate 2 from "set of tools" with 4 screws (pos. 3) to the bearing hub.
- Place bearing assembly vertically on a working surface.
- Undo grooved nut 1 with the hook wrench (**left-hand thread**).
- Screw in screws 4.

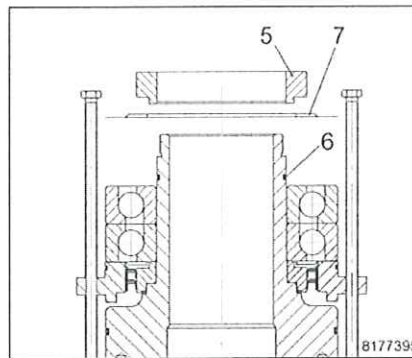

Fig. 74

- Remove ring 5 and gasket 6.
- Remove Nilos ring 7.
- Check gasket 6 for damage and replace if necessary.

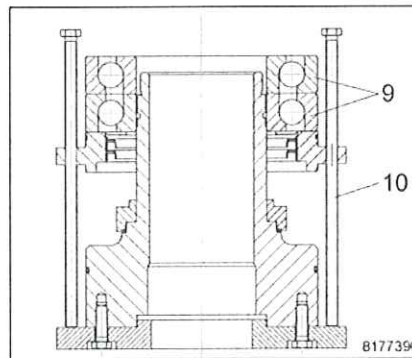

Fig. 75

- Force off the bearing assembly with angular contact ball bearings 9 as illustrated by turning screws 10.
- Check radial packing rings for damage and replace if necessary.

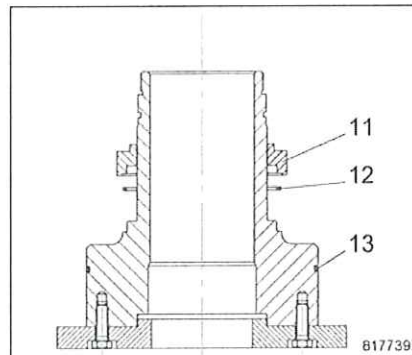

Fig. 76

- Remove ring 11 and gasket 12.
- Check gaskets 12 and 13 for damage and replace if necessary.

Fitting



Important: only for bearings without relubrication facility. This is important for the fitting position of the radial packing rings

- Clean all parts carefully. Replace worn or damaged parts immediately.
- Remove the slushing oil from the roller bearings. Be sure to observe the instructions on page 48.
- Pack the bearing space and roller bearing with grease. Grease quantity and quality are specified in the "Lubrication and maintenance schedule" (definitive schedule is in the parts list supplied with the decanter).

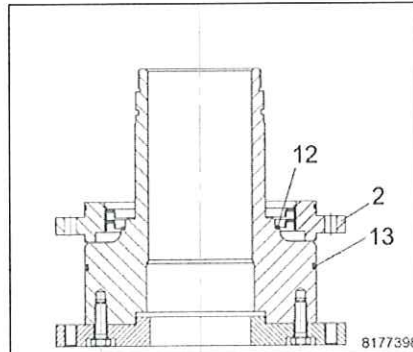

Fig. 77

- Slide O-ring seal onto the hub.
- Place the preassembled bearing cover 2 as centrally as possible on the plane surface of the bearing hub.

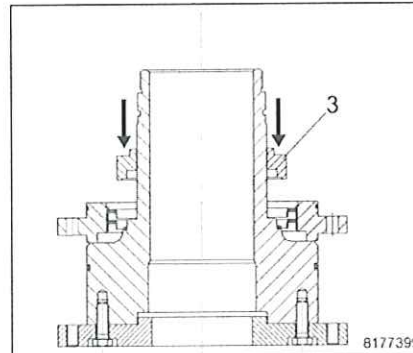

Fig. 78

- Slide ring 3 onto the hub. Ensure that the radial packing rings do not get damaged.

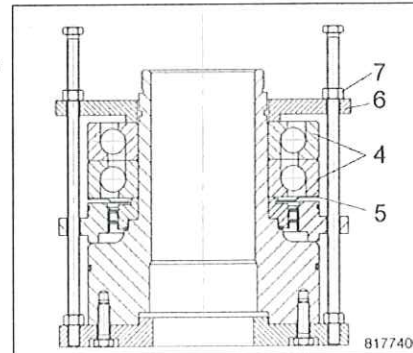

Fig. 79

- Fit Nilos gasket 5.
- Fit the angular contact ball bearings 4 packed with grease so that the wide inner rims face outwards (O arrangement). Otherwise the bearings will be destroyed during assembly.
- Mount tool 6 and force the bearing onto the bearing hub by evenly turning nuts 7. Pull the first bearing onto the bearing hub until there is adequate guidance for the second bearing. Then **firmly** drive in both bearings until they are fully home.

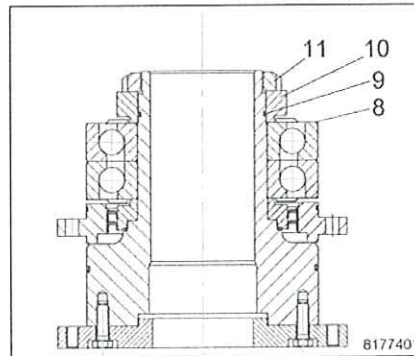

Fig. 80

- Fit Nilos gasket 8.
- Fit O-ring seal 9.
- Mount ring 10.
- **Firmly** tighten the grooved nut 11 with the hook wrench (left-hand thread).
-

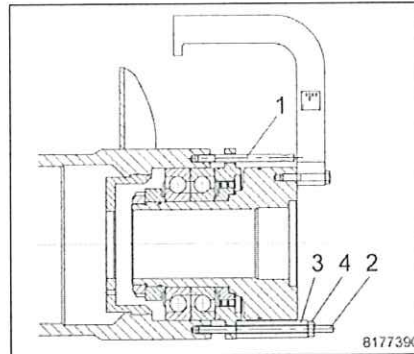
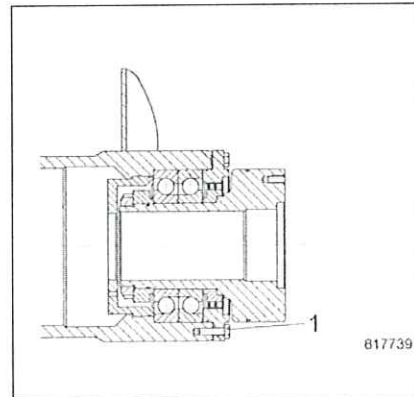

Fig. 81

- Screw two guide rods M16 (pos. 1) into the scroll body.
- Use the lifting device to carefully slide the pre-assembled bearing assembly over the guide rods into the scroll body.
- Screw in two threaded rods M16 (set of tools). Pull the bearing assembly with hexagon nuts 4 and sleeves 3 into the scroll body.



- Remove the lifting device 2.
- Tighten the bearing assembly evenly and crosswise with the aid of 14 hex head screws M16x55 (pos. 1). Rotate the bearing hub if necessary.

Note:

- Required screw quality: ISO 4014, 1.4571, A4-70
- Required torque (greased screws): 110 Nm
- When correctly assembled, the gap »S« between scroll and bearing cover is 0.4-1.4 mm.

4.9.2 Removing the scroll bearings (solids side)



Do not loosen any part of the machine before the decanter bowl has come to a standstill.

- Remove scroll, see 4.7.2.
- Remove main bowl bearing on the solids side, see 4.10.3.

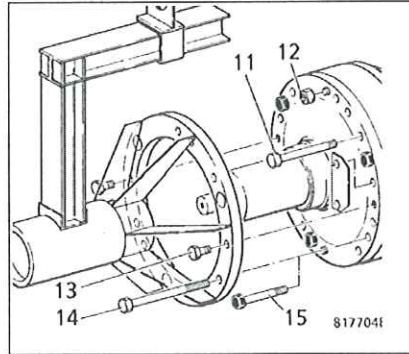

Fig. 82

- Detach the gearbox from the flange. To do this:
 - Unscrew two hexagon nuts 12.
 - Undo ten hex head screws 11 (M30x260).
 - Unscrew three of six marked hex head screws 15 (M30x220).
 - Attach the lifting device to the gearbox with two hex head screws 13.
 - Force off the gearbox and remove it.

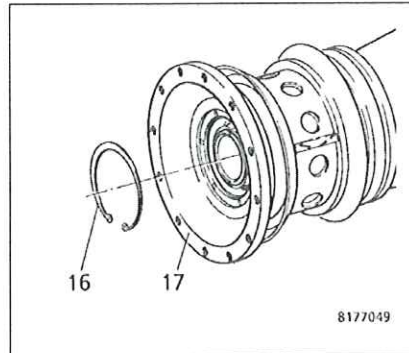

Fig. 83

- Take off retaining ring 16.

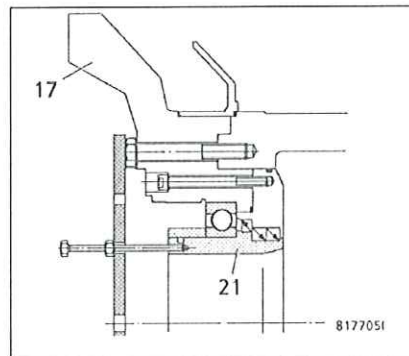

Fig. 84

- Mount pulling device. Remove bearing bush 21 with radial packing ring and grooved ball bearing.

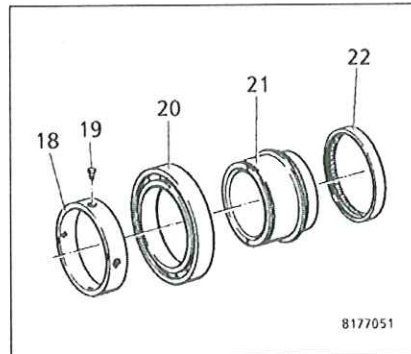

Fig. 85

- Loosen hex head screws 19. Remove ring 18. Pull grooved ball bearing 20 off the bearing bush.

4.9.3 Fitting the scroll bearings (solids side)

- Clean all parts carefully. Replace worn or damaged parts immediately.
- Remove the slushing oil from the roller bearings. Be sure to observe the instructions on page 48.
- Roller bearings with special tolerances are required for all bearing points. Use only those roller bearings specified in the parts list.
- To ensure perfect running of the bowl, all plane surfaces and centering rims must be smooth and clean.
- When fitting the radial packing rings, pay attention to section 4.15.1.

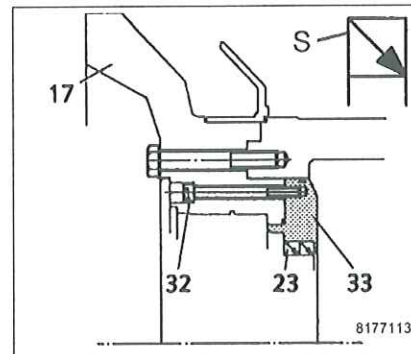

Fig. 86

- Replace the radial packing rings 23 when the sealing lip is no longer soft and elastic.
- Undo screws 32. Remove cover 33 (through the bowl).
- Remove the grease from the seat for the radial packing rings using a suitable liquid.
- Apply Loctite adhesive type 245 to the entire circumference of the radial packing rings and fit in the cover.
- Mount cover 33.

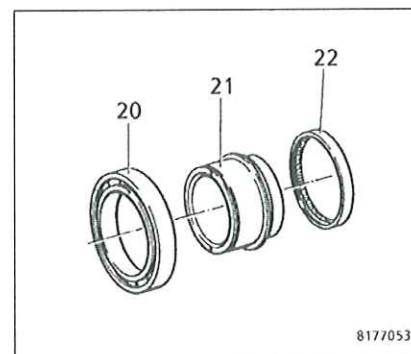

Fig. 87

- Remove the grease from the seat for the radial packing rings using a suitable liquid.
- Apply Loctite adhesive type 245 to the entire circumference of the radial packing rings and fit in the cover.
- Pull radial packing ring 22 and grooved ball bearing 20 onto the bearing bush 21.

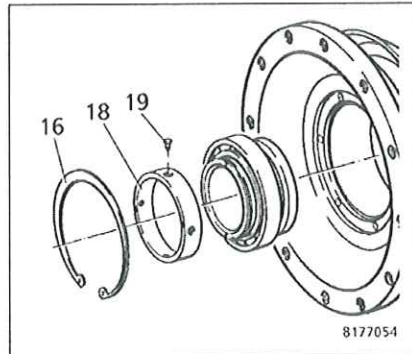

Fig. 88

- Fit the pre-assembled bearing bush into the flange and press the grooved ball bearing at the outer ring into the flange.
- Slide on ring 18 and fasten with hex head screws 19.
- Mount retaining ring 16.

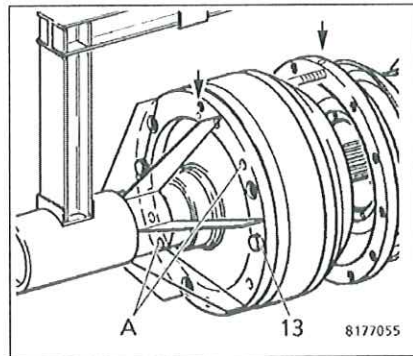

Fig. 89

- Attach the lifting device to the gearbox with two hex head screws 13.
- Introduce the gearbox into the housing with the lifting device and thread in the studs. Pay attention to the "O" marks on Cyclo gear and flange.

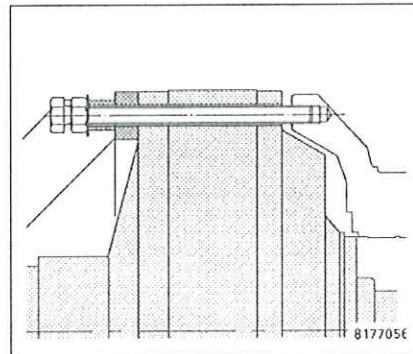

Fig. 90

- Pull the gearbox into the flange through holes A (see preceding figure).

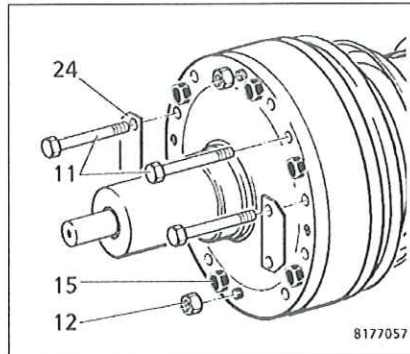

Fig. 91

- Screw in the marked hex head screws 15.
- Screw on two hexagon nuts 12.
- Screw in the marked hex head screws 11. Note:
 - The two plates 24 must cover the tapholes (offset through 180 degrees).
 - Do not adjust the speed sensor until the belt pulley for the bowl drive has been mounted.

- Tighten all hex head screws and hexagon nuts evenly and crosswise with a torque wrench.
Required torques for greased screws:
 - M30x260, 8.8 = 1060 Nm (gear ZS 626),
 - M24x250, 8.8 = 540 Nm (gear ZS 625)
 Use a power assist tool. Support the power assist tool on the shaft of the gear.
- Fit main bowl bearing, see 4.10.1.

4.10 Replacing the main bowl bearings

On the liquid side the bowl is supported by a cylindrical roller bearing.

On the solids side the bowl is supported by a grooved ball bearing and a cylindrical roller bearing.

The following should be borne in mind when replacing the bearings:



- "Lubrication and maintenance schedule"
- Always use complete tools and use them only for the intended application, see "Set of tools".
- Only use suitable hoists and lifting equipment.
- Roller bearings with special tolerances are used in the decanter. Only use those roller bearings specified in the parts list.
- The radial sealing rings for sealing off the main bowl bearings are marked with a "T".

4.10.1 Removing the main bowl bearings (liquid side)



Do not loosen any part of the machine before the decanter bowl has come to a standstill.

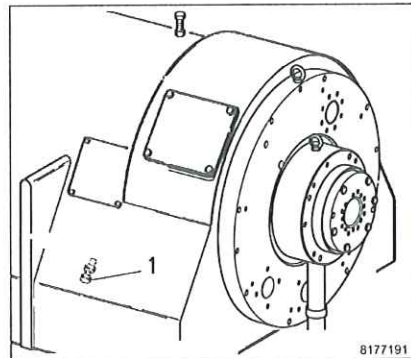

Fig. 92

- Disconnect the feed line.
- Screw in the lower lock screws 1 and tighten them lightly against the bowl.

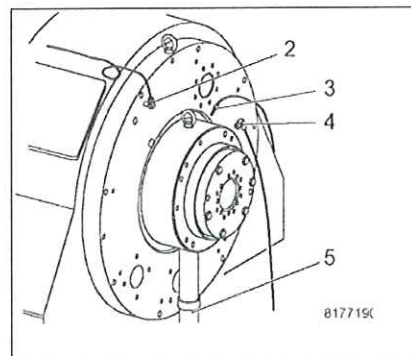

Fig. 93

- Remove temperature probe 3, oil feed 5 and flush line 2.

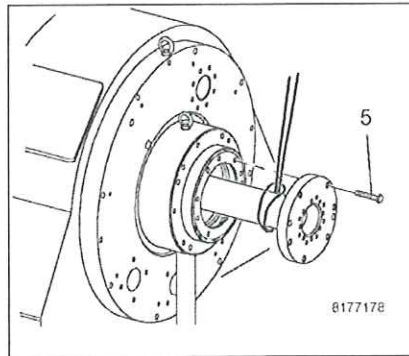

Fig. 94

- Undo hex head screws 5.
- Force off the feed tube 6 with 2 puller screws (M16).
- Pull out the feed tube (107 kg) by hand a little way, suspend it in a hoist and withdraw it completely.

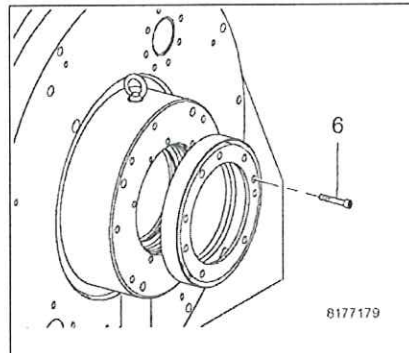

Fig. 95

- Undo Allen screws 6. Force off flange with 2 puller screws M12.

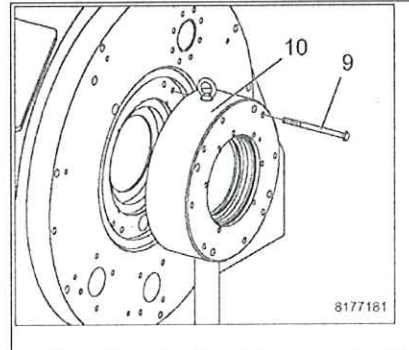

Fig. 96

- Undo hex head screws 9.
- Force off labyrinth ring 10 with four puller screws M 16.

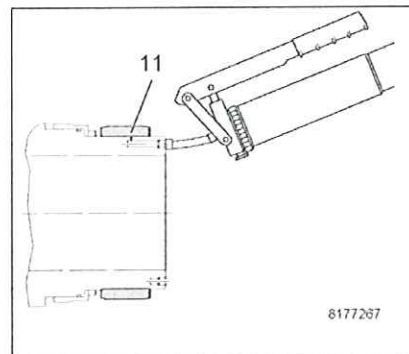

Fig. 97

- Prepare for removing bearing inner ring 11. To do this:
 - Screw the grease nipple into the bearing hub.
 - Inject grease until grease emerges from under the bearing inner ring. This will happen at 480 bar at the latest.

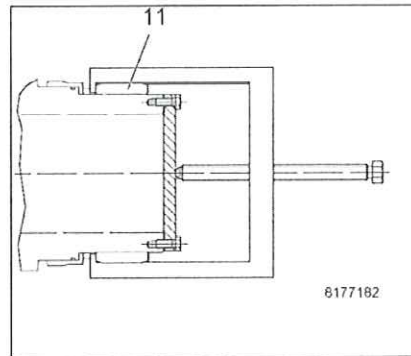

Fig. 98

- Withdraw the bearing inner ring as shown in the figure.

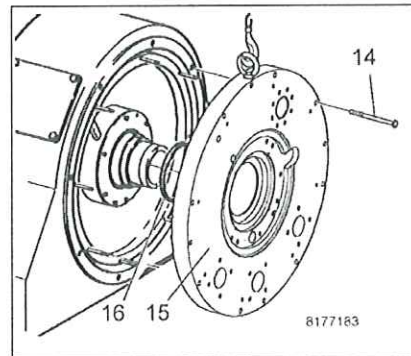

Fig. 99

- Undo screws 14.
- Suspend bearing cover 15 (600 kg) in a hoist and force it off.
- Withdraw sealing ring 16 from its seat.

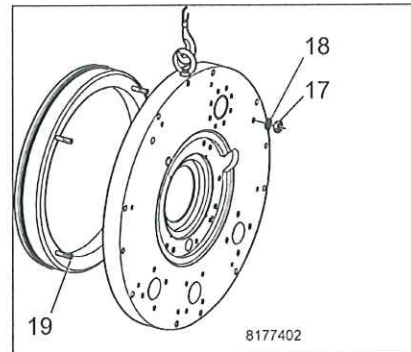

Fig. 100

- Unscrew nuts 17 with washers 18.
- Remove ring 19 from the bearing cover.

4.10.2 Fitting the main bowl bearings (liquid side)

- Clean all parts carefully. Replace worn or damaged parts immediately.
- To ensure perfect running of the bowl, all plane surfaces and centering rims must be smooth and clean.
- When fitting the radial packing rings, pay attention to section 4.15.1.

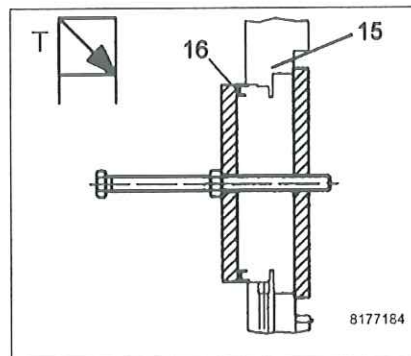

Fig. 101

- Remove the grease from the seat for the radial packing ring using a suitable fluid.
- Apply Loctite adhesive type 245 to the entire circumference of the radial packing ring.
- Fit radial packing ring 16 in bearing cover 15.

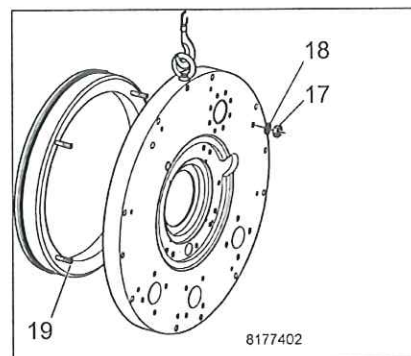

Fig. 102

- Check gasket in ring 19 and replace if necessary.
- Fit ring 19 in the bearing cover and fasten with nuts 17 and washers 18.

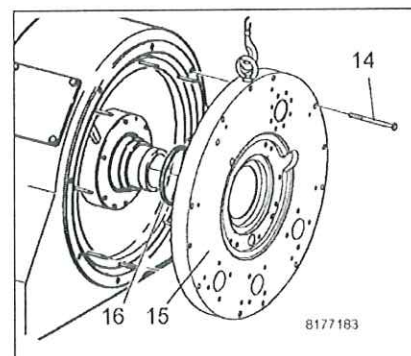

Fig. 103

- Slide the inner ring of the cylindrical roller bearing onto the bearing hub (if necessary, gently heat inductively but not above 100 °C).
- Screw two threaded spindles into the housing to guide bearing cover 15.

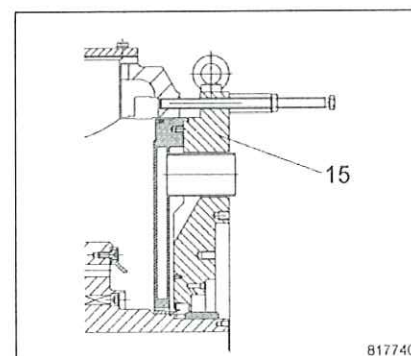

Fig. 104

- Suspend the bearing cover in the hoist, carefully slide it onto the bearing hub and tighten opposite hex head screws M 20x100.
Required screw quality:
ISO 4014, 1.4571, A4-70

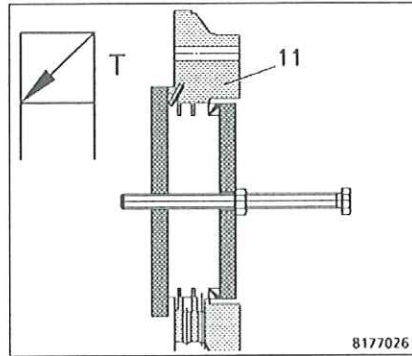

Fig. 105

- Remove the grease from the seat for the radial packing ring using a suitable fluid.
- Apply Loctite adhesive type 245 to the entire circumference of the radial packing ring.
- Fit radial packing ring into labyrinth ring 11.

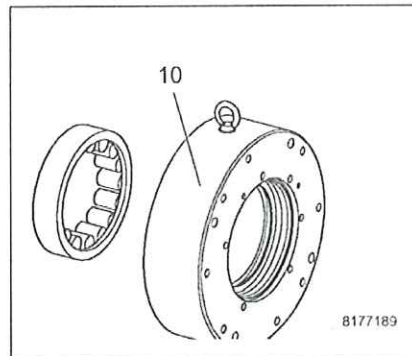

Fig. 106

- Press the outer ring of the cylindrical roller bearing into the bearing set of the labyrinth ring 10.

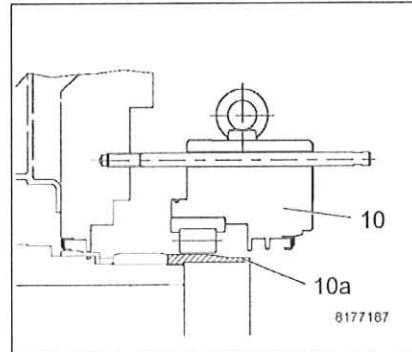

Fig. 107

- Check that the bowl is exactly centrally aligned (correct if necessary).
- Mount labyrinth ring 10 with the aid of 4 threaded spindles and sleeve 10a.
- Fasten labyrinth ring 10 with 8 hex head screws M 16x180.
Required screw quality:
ISO 4014, 1.4571, A4-70

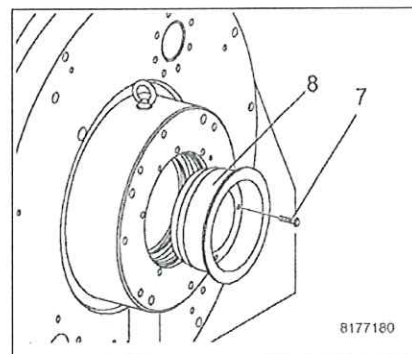

Fig. 108

- Fit sleeve 8 and bolt tight.

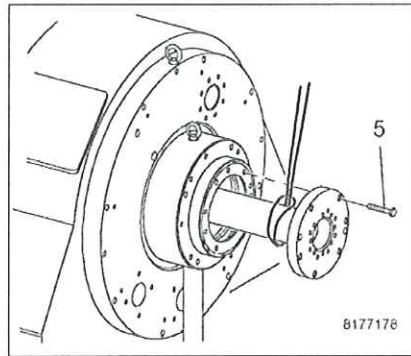

Fig. 109

- Thread in and bolt tight the feed tube with 6 hex head screws M 16x120.
Required screw quality:
ISO 4014, 1.4571, A4-70

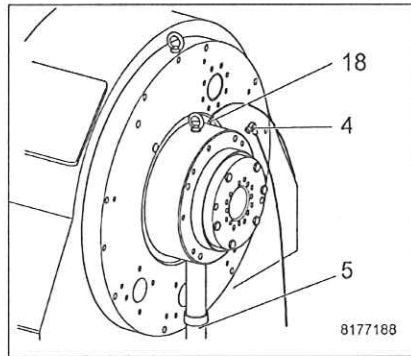

Fig. 110

- Install oil feed line 4 and oil return line 5.
- Attach temperature probes 18.

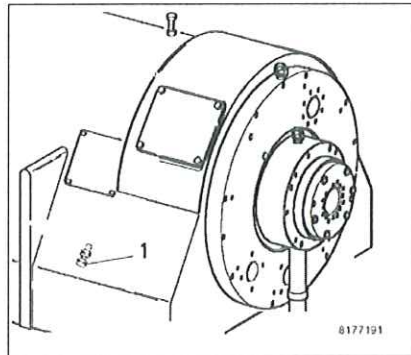

Fig. 111

- Connect the feed line.
- Loosen and lock the two lower lock screws 1.

4.10.3 Removing the main bowl bearing (solids side)



Do not loosen any part of the machine before the decanter bowl has come to a standstill.

- Slacken the drive belts and remove the belt pulleys, see 5.4.1.
- Tighten the bowl lock screws on the solids side.

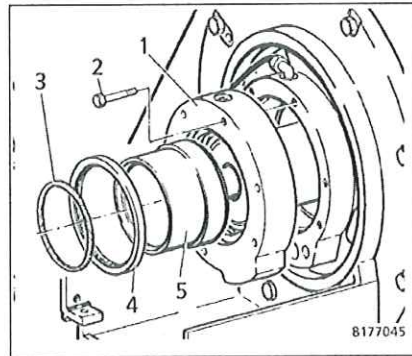

Fig. 112

- Undo the hex head screws 2 on the bearing cover.
- Force off bearing cover 1 (2 x M16) and remove together with sleeve 5 and grooved ball bearing.

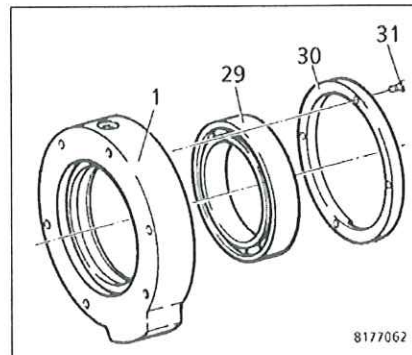

Fig. 113

- Remove screws 31 and ring 30.
- Drive grooved ball bearing 29 out of bearing cover 1.

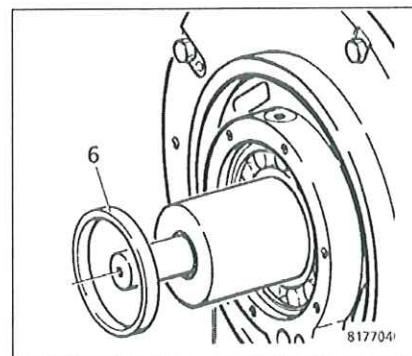

Fig. 114

- Take off ring 6 in front of the cylindrical roller bearing.
- Adjust the bowl lock screws so that the cage of the cylindrical roller bearing can be rotated by hand.

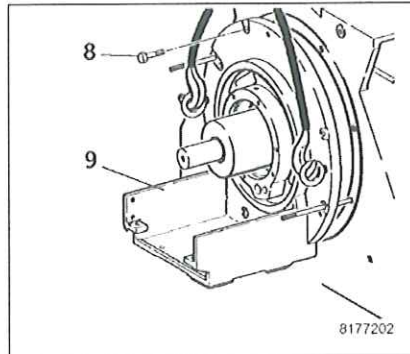

Fig. 115

- Attach the hoist to bearing housing 9 as shown in the figure.
- Undo hex head screws 8.
- Force off bearing housing (3 x M20). Use guide rods!
- Drive outer ring of the cylindrical roller bearing out of the bearing housing.

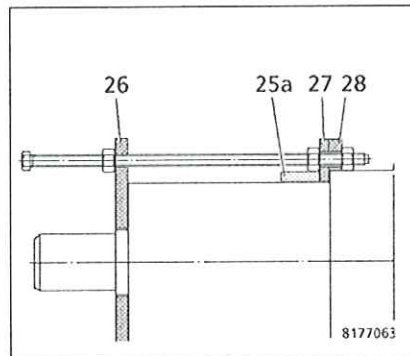

Fig. 116

- Pull off inner ring 25a of the cylindrical roller bearing (if necessary, gently heat but not above 100 °C; use the measuring instrument!).

4.10.1 Fitting the main bowl bearings (solids side)

- Clean all parts carefully. Replace worn or damaged parts immediately.
- Remove the slushing oil from the roller bearings. Be sure to observe the instructions on page 48.
- Carefully clean the contact surfaces between the temperature probes and the bearing outer ring. This avoids measuring errors.
- To ensure perfect running of the bowl, all plane surfaces and centering rims must be smooth and clean.
- When fitting the radial packing rings, pay attention to section 4.15.1.

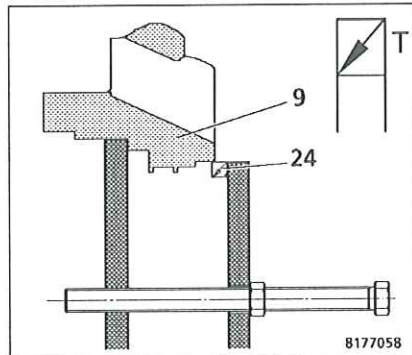

Fig. 117

- Remove the grease from the seat for the radial packing ring using a suitable fluid.
- Apply Loctite adhesive type 245 to the entire circumference of the radial packing ring.
- Fit radial packing ring 24 in bearing housing 9.
- Fit outer ring of the cylindrical roller bearing in bearing housing 9.

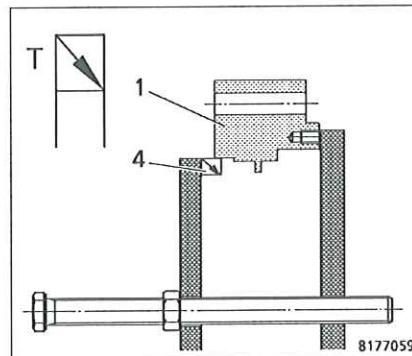

Fig. 118

- Remove the grease from the seat for the radial packing ring using a suitable fluid.
- Apply Loctite adhesive type 245 to the entire circumference of the radial packing ring.
- Fit radial packing ring 4 in bearing cover 1.

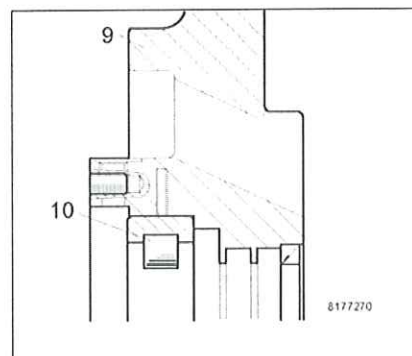

Fig. 119

- Fit cylindrical roller bearing 10 in bearing cover 9.

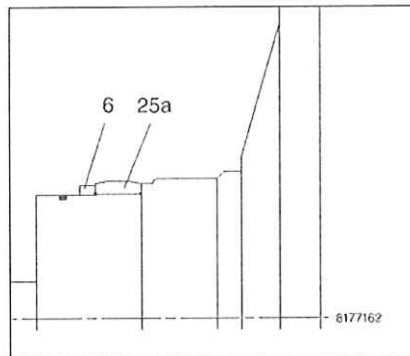

Fig. 120

- Pull the inner ring of cylindrical roller bearing 25 and ring 6 onto the gear hub.

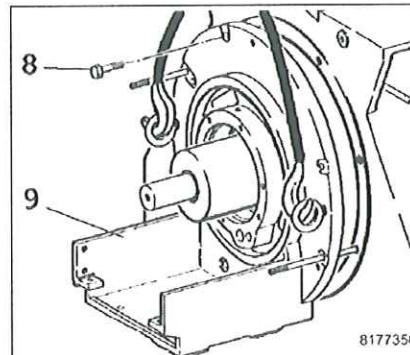

Fig. 121

- Check that the bowl is exactly centrically aligned (correct if necessary).
- Screw two threaded spindles into the housing to guide bearing housing 9.
- Use a hoist to guide the bearing housing onto the threaded spindles and fasten with 8 hex head screws M 20x75.
Required screw quality: ISO 4014, 1.4571, A4-70

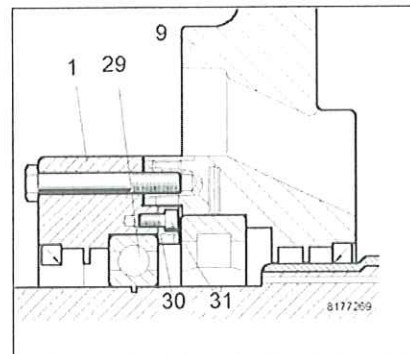

Fig. 122

- Fit grooved ball bearing 29 in bearing cover 1. Fasten ring 30 with screws 31.
- Bolt bearing cover 1 and bearing housing 9 with 6 hex head screws M 16x110.
Required screw quality: ISO 4014, 1.4571, A4-70
- For further assembly, proceed in reverse order from removal.

4.11 Drive belts

The condition and correct position of the drive belts must be checked regularly. The inspection and replacement intervals are given in the "Lubrication and maintenance schedule". Signs of insufficient belt tension or worn belts can be:

- Increased noise level due to flapping belts.
- Excessive speed drop under load (bowl or differential speed).

4.11.1 Drive belts (primary drive)

When tensioning and replacing the V-belts, bear in mind the following:

- Always replace the complete set of belts (bowl and scroll drive). Only then are the belts of equal length. Equal length is a pre-requisite for uniform tension and smooth running.
- Only use belts as specified in the parts list. Only then do the belts satisfy all requirements.
- The belt tension must also be checked when the decanter is supplied as a complete assembly.
- Check the belt tension after 0,5 - 1 operating hours. Use measuring instrument 0003-0534-000.

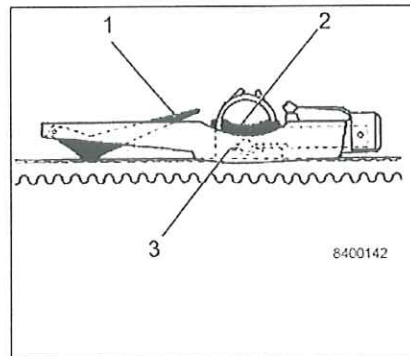

Fig. 123

The measuring instrument consists of:

- 1 Indicating arm
- 2 Pressure surface
- 3 Pressure spring

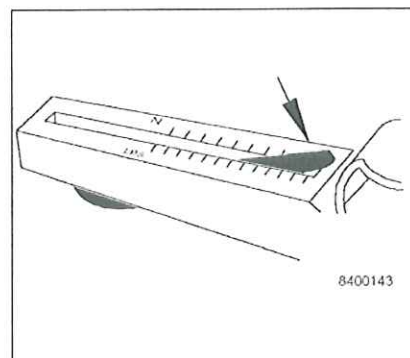

Fig. 124

- Push the indicating arm to the end of the scale.

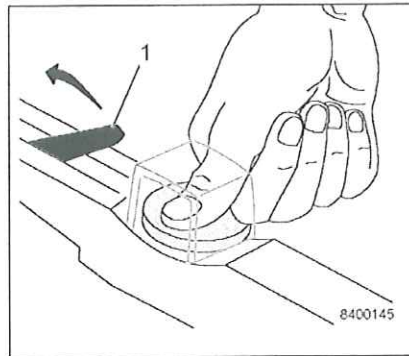

Fig. 125

- Place the measuring instrument in the centre between the two belt pulleys on one of the belts.
- Press gently with one finger against the pressure area. The indicating arm will deflect on the scale span.
- Stop pressing when you hear or feel a click.
- Carefully lift off the measuring instrument without moving the indicating arm.

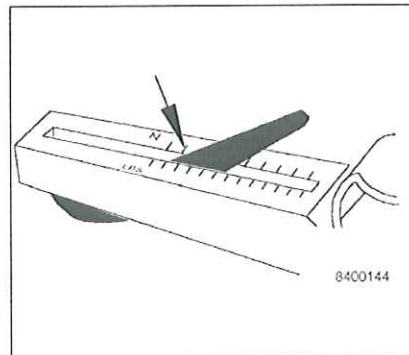

Fig. 126

- Read off the value at the point of intersection between the upper edge of the indicating arm and the scale span.
The setpoint for optimally tensioned belts is:
 - new belts: $1150 \pm 50\text{N}$
 - used belts: $950 \pm 50\text{N}$
- Decrease or increase the belt tension depending on the measuring result until they are within the desired tension tolerance.

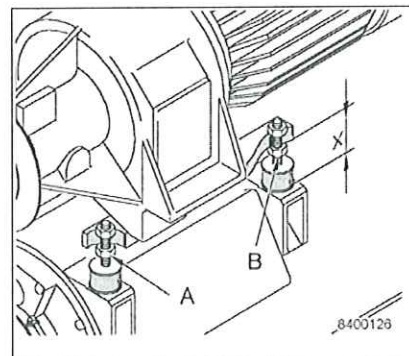

Fig. 127

Adjusting belt tension:

- Adjust clearance X. To do this, turn nuts A and B until the required belt tension is attained (the motor must be in horizontal position).
- Rotate the belt pulleys to ensure uniform stretching of the belts.
- Repeat the measuring procedure.

4.11.2 Drive belts (secondary drive)

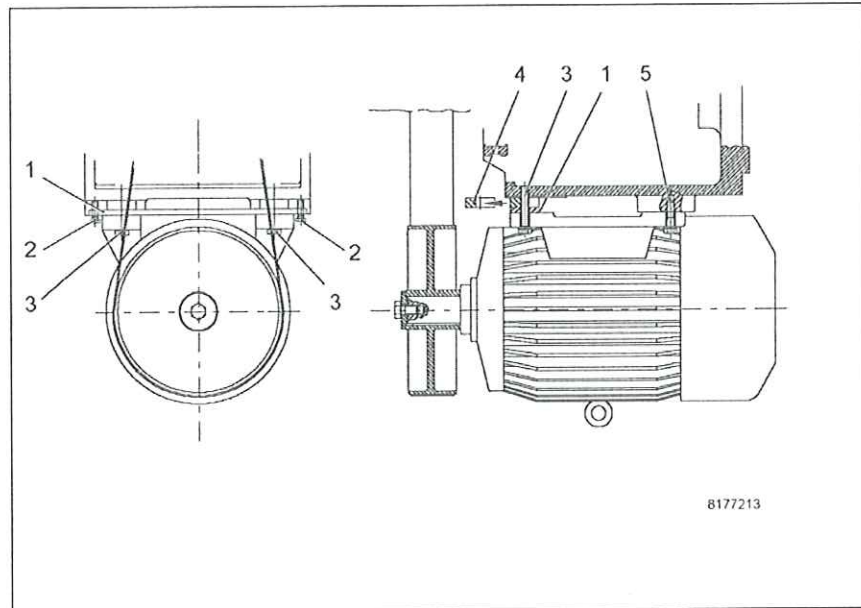

Fig. 128

Removal



Do not loosen any part of the machine before the decanter bowl has come to a standstill.

- Undo the rear fastening screws 5 (do not unscrew completely).
- Undo the front fastening screws 3 until the spacers 4 can be taken out.
- Slacken the belts by turning screws 2. Take off the belts.

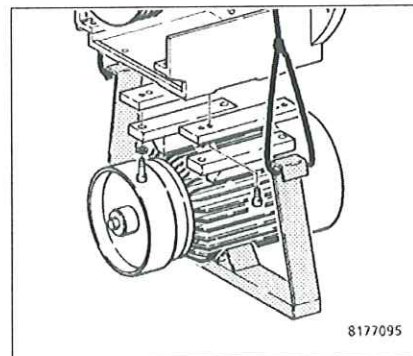

Fig. 129

- If the secondary motor is to be dismantled, use the load suspension device provided.

Fitting

Assembly is carried out in reverse order. Note the following:



- Only use belts as specified in the parts list. Only then do the belts satisfy all requirements.
- Clean all parts thoroughly. Replace worn or damaged parts immediately.

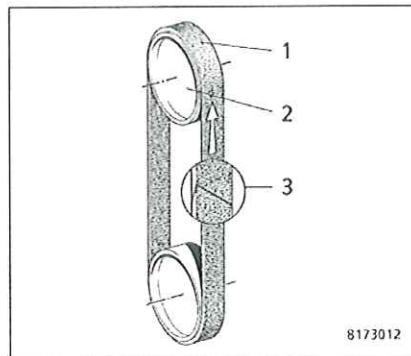

Fig. 130

- When mounting the belts, note the running direction. They must be fitted so that the seam or joint 3 is positioned as shown in the opposite figure.
- When assembled correctly, the belt tension will be correct.

4.12 Bearing change - oil feed

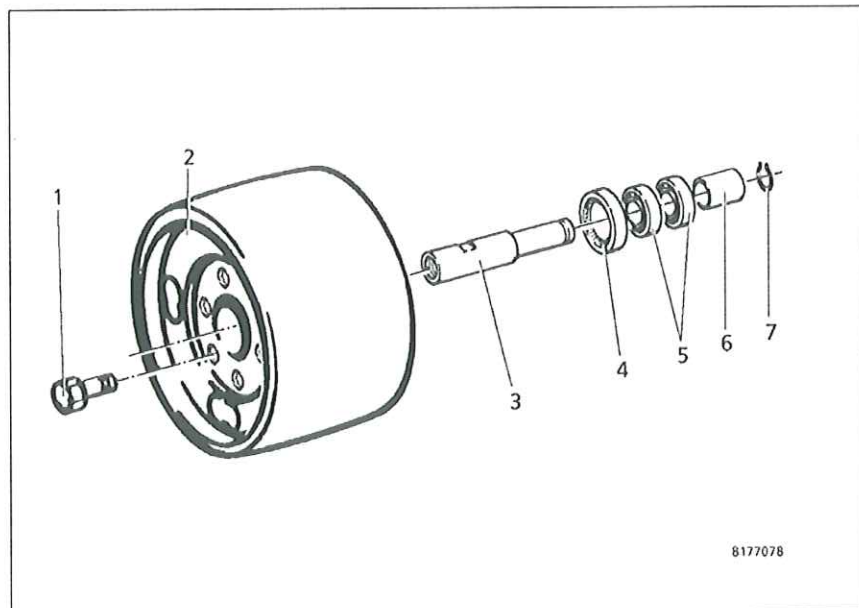

Fig. 131



Do not loosen any part before the bowl has come to a standstill.

- Keep to "Lubrication and maintenance schedule"
- Unscrew hex head screws 1. Force off flat belt pulley 2 (2xM10).
- Drive out pipe with complete bearing assembly. Take off retaining ring 7 and pull off roller bearing.
- Carefully clean all parts. Replace worn or damaged parts immediately.
- Roller bearings with special tolerances are used in the decanter. Only use those roller bearings specified in the parts list.

4.12.1 Bearing change — drive (transmission house)

Removal



Do not loosen any part of the machine before the decanter bowl has come to a standstill.

- Only use suitable hoists and load-carrying equipment.
- Always use complete tools and use them only for the intended application, see "Set of tools".
- Drain oil, see above.

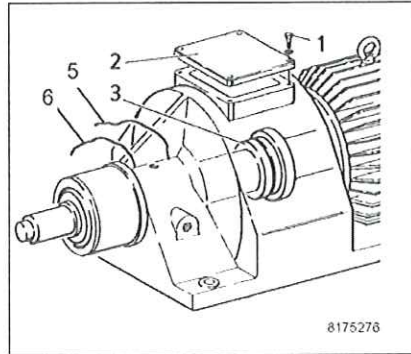

- Disconnect electric leads.
- Undo screws 1. Remove cover 2.
- Remove temperature probes 5 and 6.

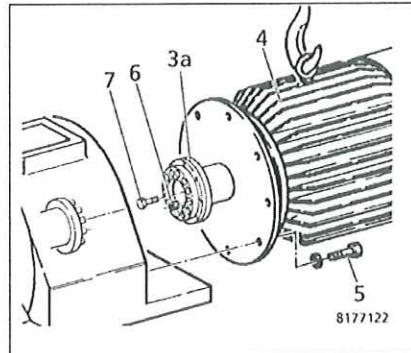

- Suspend motor 10.16 cm a hoist.
- Undo hex head screws 5. Pull the motor off the housing (keep an eye on rubber sleeves 6).

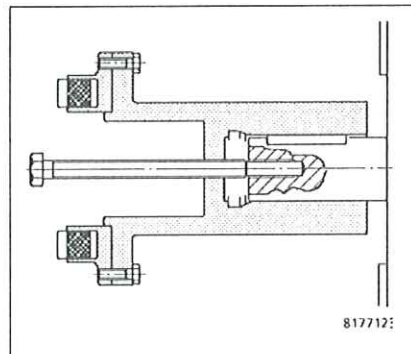

- Pull clutch half 3a and hub off the motor shaft. The puller screw has **fine-pitch threads**.

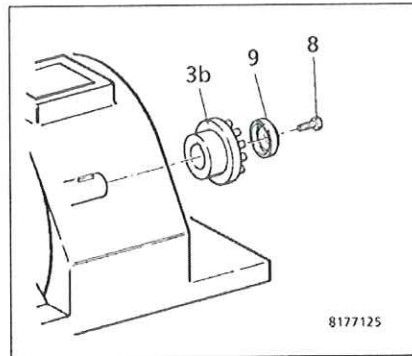

- Undo hex head screw 8.
- Pull ring 9 together with clutch half 3b off the shaft.
- Take out the feather key.

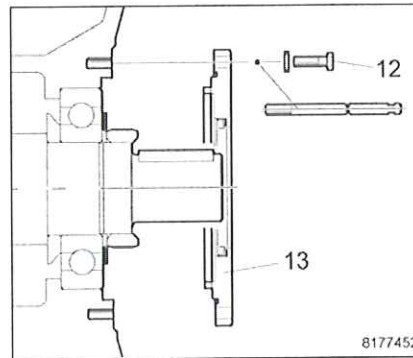

- Undo hex head screws 12. Mount the guide bolt.

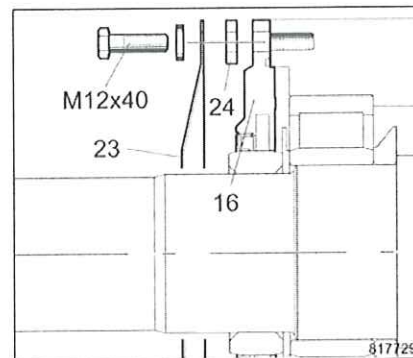

- Unscrew the hex head screws M12x40. Remove plate 23 and distance bushes 24.

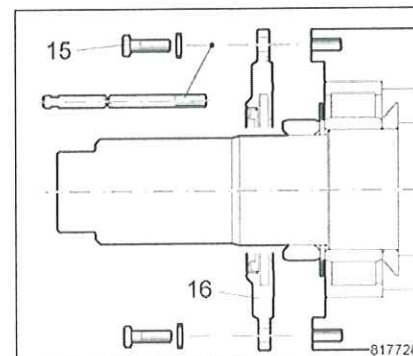

- Undo hex head screws 15. Mount the guide bolt.
- Force off bearing cover 16.

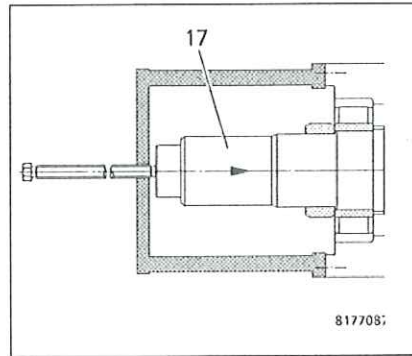

- Mount the device. Drive the shaft with grooved ball bearing and the inner ring of the cylindrical roller bearing out of the housing.
- Use a puller to pull the grooved ball bearing and inner ring of the cylindrical roller bearing off the shaft (if necessary, gently heat but not above 100 °C).

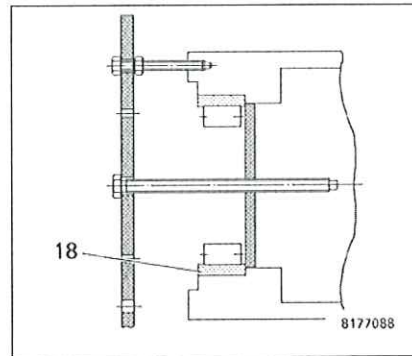

- Pull out the parts of the cylindrical roller bearing still in the housing with a pulling device.

Fitting

Assembly is carried out in reverse order. Note the following:

- Clean all parts carefully. Replace worn or damaged parts immediately.
- Remove the slushing oil from the roller bearings. Be sure to observe the instructions on page 48.
- Roller bearings with special tolerances are required for all bearing points. Use only those roller bearings specified in the parts list.

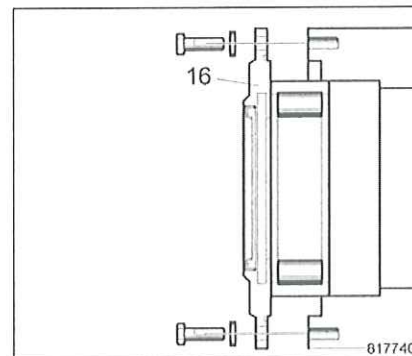

- Pull the outer ring of the cylindrical roller bearing into the housing with the aid of cover 16.
- Remove cover 16.

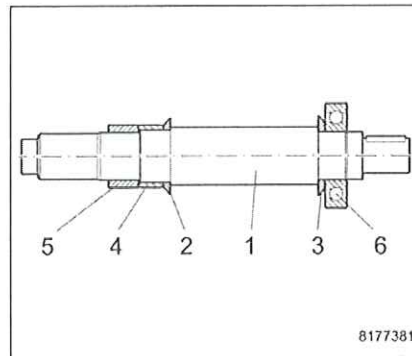

- Pre-assemble shaft 1.
 - Slide on rings 2 and 3.
 - Pull off inner ring 4 of the cylindrical roller bearing
 - Slide on protective sleeve 5 (see "Set of tools").
- Slide on grooved ball bearing 6.

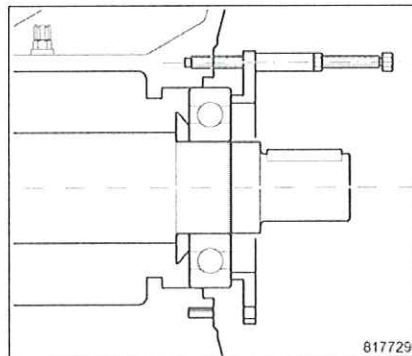

- Pull the pre-assembled shaft into the housing.

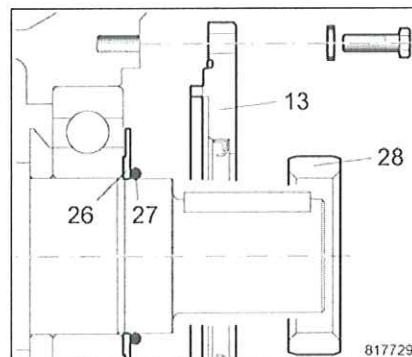

- Mount disk 26 and gasket 27 as illustrated.
- Fasten cover 13 with 6 hex head screws M12x35.
Required screw quality: ISO 4014, 1.4571, A4-70
- Fit bush 28 last so as to avoid damaging the radial packing ring.

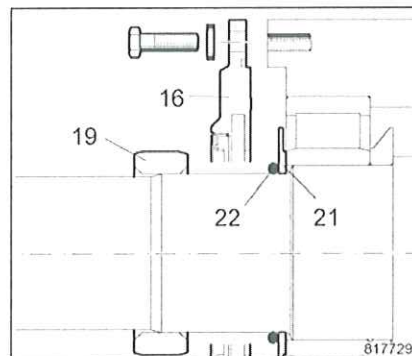

- Slide plate 21 and gasket 22 onto the shaft.
- Fasten cover 16 with 3 hex head screws M12x35.
Required screw quality: ISO 4014, 1.4571, A4-70
- Insert bush 19 last so as to avoid damaging the radial packing ring.

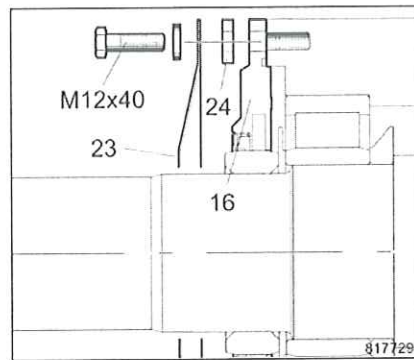

- Mount plate 23 with distance bushes 24 and 3 hex head screws M12x40 on cover 16.
Required screw quality: ISO 4014, 1.4571, A4-70

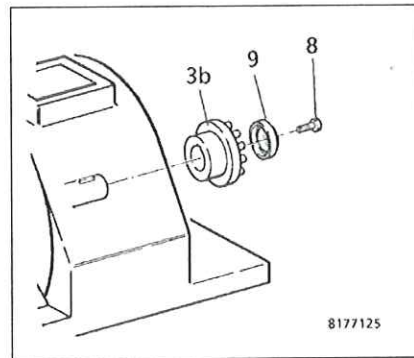

- Pull clutch half 3b onto the shaft and secure with washer 9 and hex head screw 8.

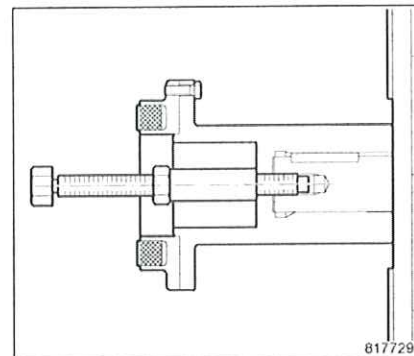

- Pull clutch half 3a onto the motor shaft and fasten with hex head screw M20x65. Note:
 - Coat screw with Loctite 245.
 - Required screw quality: ISO 4014, 1.4571, A4-70
 - Required torque: 215 Nm

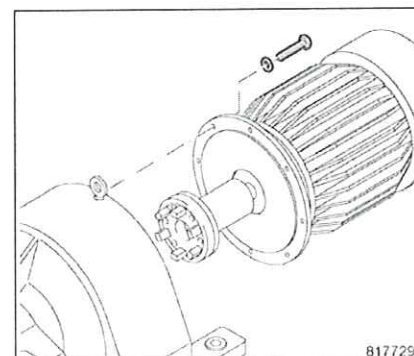

- Bolt the motor to the housing with screws 5.

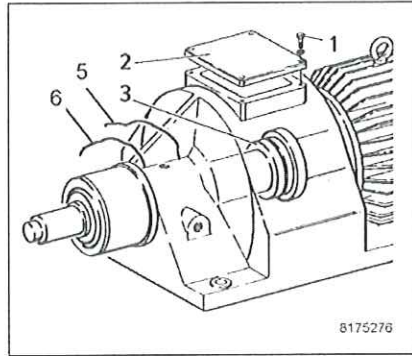

- Fasten cover 2.
- Attach temperature probes 5 and 6.

Note:

- Carefully clean the contact surfaces between the temperature probes and the bearing outer ring. This avoids measuring errors.
- Mark "K" stands for clutch side
- Mark "R" stands for belt side

4.13 Oil circulation lubrication system

Maintenance work to be carried out regularly on the oil circulation lubrication system.

- Check oil level.



- Change oil.

Important:

- Be sure to drain the oil left in the gear. To do this, undo the oil drain screws on the gearbox.
- Always fit the oil drain screws with new gaskets.

- Replace oil filter.

- Drain condensate. Clean oil pan. Renew gasket.

The necessary maintenance, maintenance intervals and oil qualities are stated in the "Lubrication and maintenance schedule" (see binding chart supplied with the spare parts list).

Suitable lubricants are specified in the "Table of lubricants". The first oil filling is supplied with the machine.

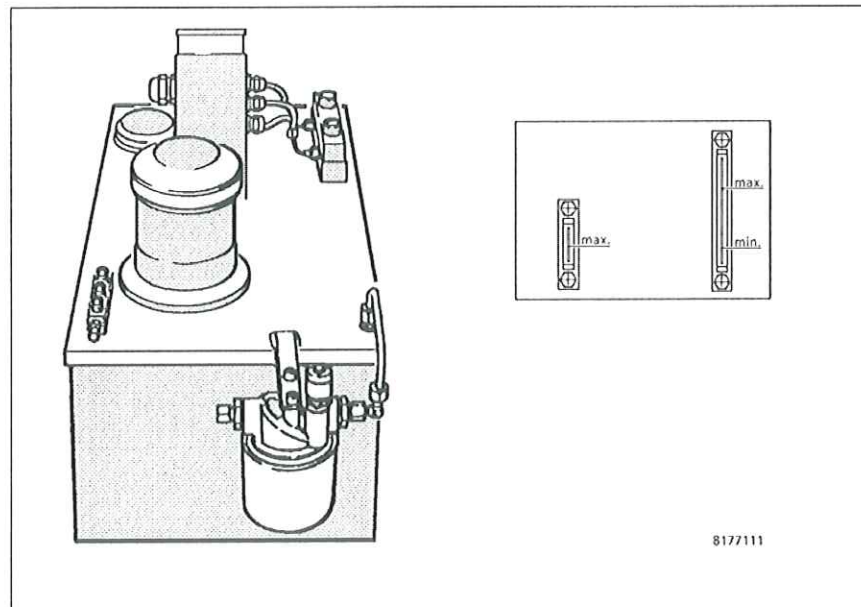

Fig. 132

Take the following action if the optional flow switch signals a fault:

- Replace oil filter
- Check level in oil tank

4.14 Cyclo gear

When working on Cyclo gears, be sure to observe the following:



- The gears may only be dismantled by specially qualified personnel.
- Never lift the gears by the drive or driven shafts. Otherwise the bearings will get damaged.
- Always use complete tools for the job they were designed for, see "Set of tools".

4.14.1 Dismantling the secondary gear



Do not loosen any part of the machine before the decanter bowl has come to a standstill.

- Remove the secondary gear, see 5.4.4.

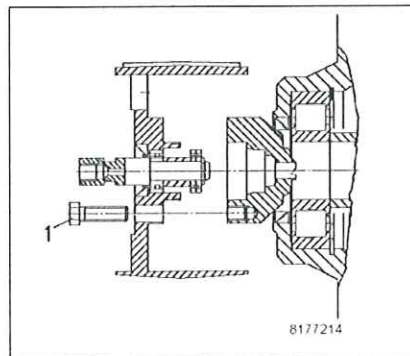

Fig. 133

- Undo hex head screws 1. Force the belt pulley together with the oil feed bearing off the shaft.

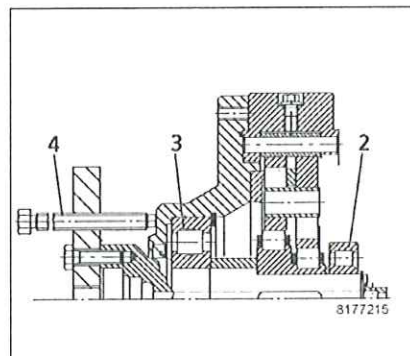

Fig. 134

- Take off the retaining ring in front of cylindrical roller bearing 2.
- Mount pulling device as shown in the figure. Pull out the drive shaft by turning screws 4.
- Pull off double eccentric sleeve with cylindrical rollers and cam disks.
- Take off retaining ring and drive cylindrical roller bearing 3 out of the gear flange.

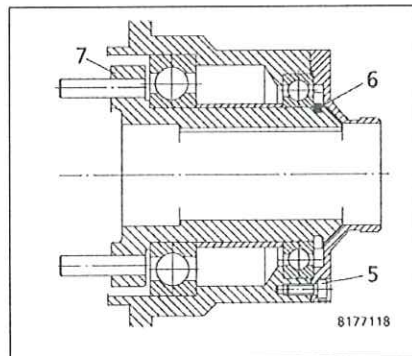

Fig. 135

- Undo Allen screws 5. Force off the bearing cover.
- Take off retaining ring 6. Force off driven shaft 7.
- Drive both grooved ball bearings out of the housing.

4.14.2 Assembling the secondary gear

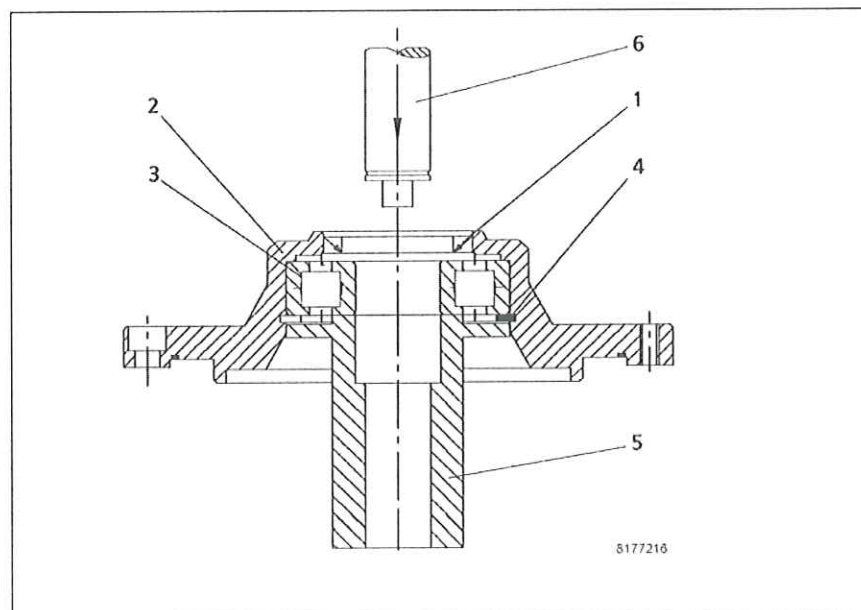

Fig. 136

- Clean all parts carefully. Replace worn or damaged parts immediately.
- Press radial packing ring 1 into flange 2.
- Press cylindrical roller bearing 3 into flange 2. Mount retaining ring 4.
- Place pre-assembled unit on mounting sleeve 5 (Part-No. 8177-9868-010).
- Press drive shaft 6 into the cylindrical roller bearing.
- For further assembly, proceed in reverse order of removal, see also 4.14.1.

4.14.3 Primary gear

Maintenance and repair of the primary gear may only be carried out by specially trained personnel or in the manufacturer's plant.

4.15 Gaskets

Important: Make sure that gaskets are in perfect condition!

In general, Perbunan gaskets of high quality standards will give satisfactory results. If highly corrosive liquids or solvents are to be processed, the decanters can be equipped with gaskets of resistant materials, e. g. FKM, EPDM or PTFE.

Gaskets of PTFE (Teflon) can, however, only be used to a certain extent since this material is of poor elasticity. Screwed unions with Teflon gaskets must be tightened firmly to ensure proper sealing.

Swollen gaskets normally reassume their original dimensions after drying.

4.15.1 Radial sealing rings

The main bowl bearings, scroll bearings and drive bearings are sealed by means of radial sealing rings.

When fitting new radial sealing rings:

- Only use the radial sealing rings specified in the parts list. Unsuitable radial sealing rings cause damage to bearings!
- Use a suitable liquid to degrease the seat for radial sealing ring.
- Apply Loctite adhesive 245 to the entire circumference of radial sealing ring.

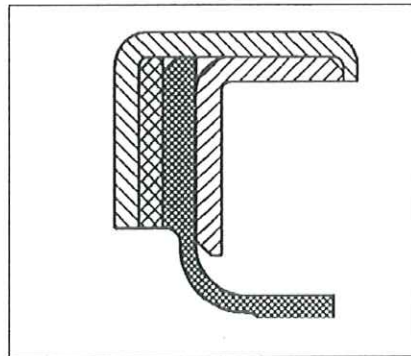

Fig. 137

- Radial sealing rings type "Elring HN 2380" are used at the following points:
 - Main bowl bearing (the radial sealing rings for sealing the main bowl bearing are marked with a "T").
 - Drive bearings

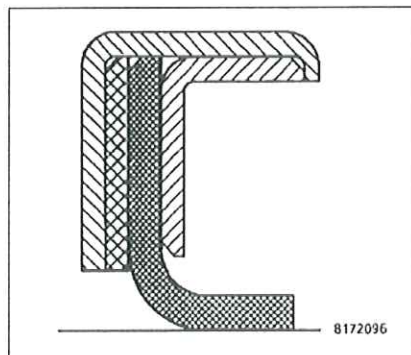

Fig. 138

- Radial sealing rings type "Elring HN 2390" are used at the following points:
 - Scroll bearings (the radial sealing rings for sealing the scroll bearings on the liquid side are marked with an "S").

4.15.2 Important mounting instructions for Elrings

The following instructions do not apply for coated bearing surfaces. Coated bearing surfaces can be recognized by the greyish surface and may not be wetted with lubricant.

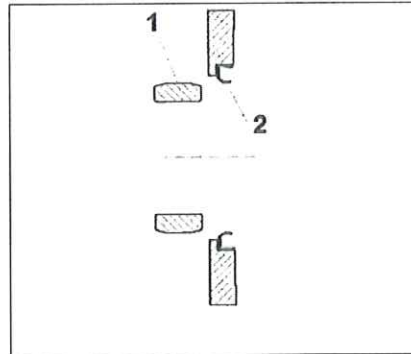

Fig. 139

- Apply a thin coat of lubricant to the bearing surfaces 1 prior to assembly.
 - Use the lubricant sparingly.
 - Be sure to use the same lubricant that is used for roller bearing lubrication.
 - Do **not** apply lubricant to the sealing lips 2 of the Elrings.
- Do not use prohibited lubricants such as mounting paste or grease. These lubricants result in the formation of oil carbon which damages the Elrings within a very short space of time!

4.16 Motor bearings

For lubricating the motor bearings, refer to the instructions of the motor manufacturer. The following applies in the case of motors supplied by Westfalia Separator:

- In the case of drive motors equipped with a post-lubrication system a nameplate specifying fat quality, fat content and lubrication interval is located near the grease nipple.
- The secondary motor has a permanent lubrication which need not be renewed.

5 Installation and adjustment

5.1	Instructions for planning the installation	96
5.1.1	Special aspects to consider when operating in hot conditions	97
5.2	Installation.....	99
5.2.1	Drive belts (primary drive).....	100
5.2.2	Direction of rotation.....	100
5.2.3	Regulating ring.....	101
5.2.4	Removing the regulating ring.....	101
5.2.5	Fitting the regulating ring	101
5.2.6	Dismantling the disk stack	102
5.2.7	Installing the disk stack.....	103
5.3	Table of speeds	104
5.4	Altering the speed	105
5.4.1	Replacing the exchangeable motor pulley.....	106
5.4.2	Replacing the exchangeable decanter pulley.....	107
5.4.3	Replacing the motor belt pulley	108
5.4.4	Replacing the decanter belt pulley	109

5.1 Instructions for planning the installation

The following documentation is required:

- Instruction manual of the decanter
 - Machine description and operating principles
 - Standard installation diagram and equipment list
 - Standard dimensioned drawing with details of space required for operation and maintenance (minimum clearance from walls and other machines)
- Terminal and circuit diagram
- Order-specific parts list
 - Additional dimensioned drawings if required
 - Table of speeds if required
 - Lubrication and maintenance schedule
- Instruction manuals of auxiliary equipment,
 - e.g. decanter monitoring unit

The following requirements are made on the feed and discharge lines and solids discharge:

- Flexible to avoid the transmission of vibrations.
- Closed to reduce noise development.
- Valves and pumps must be adapted to the product.
- **Protective devices according to EN 294 must afford the following protection:**
 - Contact with the rotating bowl must be excluded.
 - Operating personnel must not be endangered by discharged product. Danger zones must be made inaccessible.
- The feed
 - must have a shut-off device so as to be able to interrupt the product supply in case of operating malfunctions,
 - should enable uniform product supply with a constant solids content.
- Design the solids discharge to prevent damming.
 - Do not constrict the discharge.
 - Ensure adequate de-aeration of the solids chute or downstream solids tank etc.
- The solids discharge must be provided with a flow-diverting device because liquid discharges through the solids outlet during start-up, shut-down and flushing.



5.1.1 Special aspects to consider when operating in hot conditions

Steam must not pass through the decanter when it is at standstill. The steam would endanger the maintenance personnel and be an influential factor regarding corrosion in the decanter.

- Shut-off devices in the feed and discharge lines must be installed such that the shut-down decanters can be isolated from common lines.
- Vent lines must be planned and installed in such a way that the shut-off devices cannot be by-passed.
- The decanter may only be started when the shut-off devices are open.

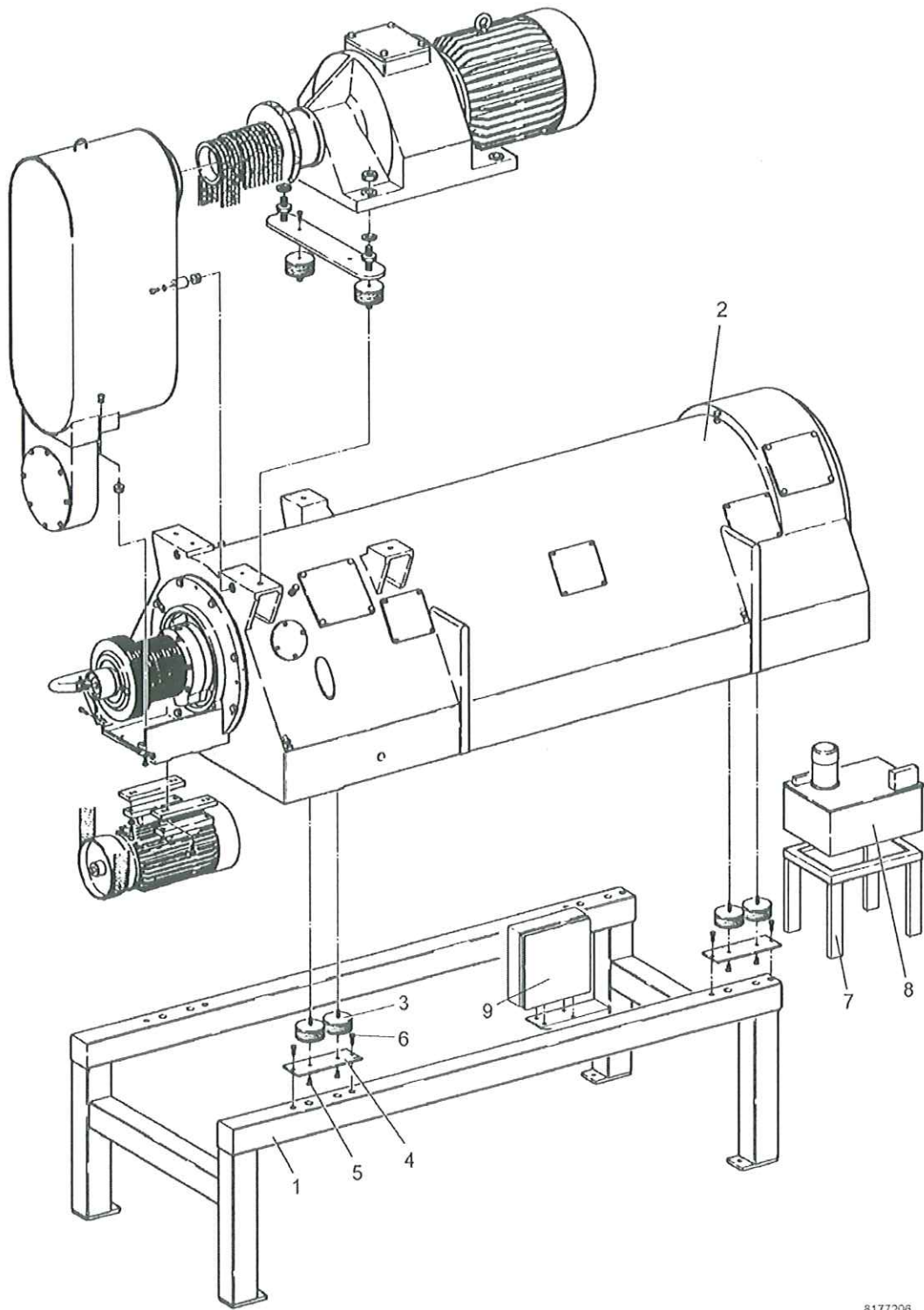

Fig. 140

8177206

5.2 Installation

Keep to the following order when assembling the decanter:



- Carefully align frame 1.
- Fit rubber-metal cushions 3 to the decanter housing 2.
- Fasten plates 4 to rubber-metal cushions 3 using screws 5.

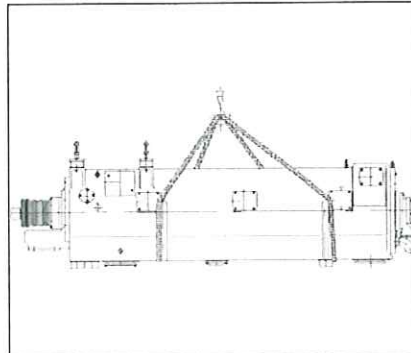

- **Caution:** Do not yet mount the drive on the decanter housing.
- Place decanter housing 2 on frame 1 and secure with screws 6.

Fig. 141

- Mount bracket 7 for gear pump unit 8 in accordance with the dimensioned drawing.
- Install the gear pump unit and connect the lines paying attention to the corresponding identification letters, see 2.5.
- Install heat exchanger 9.
- Connect feed and discharge lines. Use flexible connections to avoid transfer of vibrations to the piping system.
- Install a suitable worm conveyor or belt conveyor etc. underneath the solids discharge chute to transport the discharged solids. Bear in mind that when the liquid ring collapses (when shutting down the decanter) liquid will discharge through the solids chute.
- Adjust the bearing temperature monitoring instruments in the control cabinet so that an alarm is given at 100°C and the motor is shut down at 110°C.

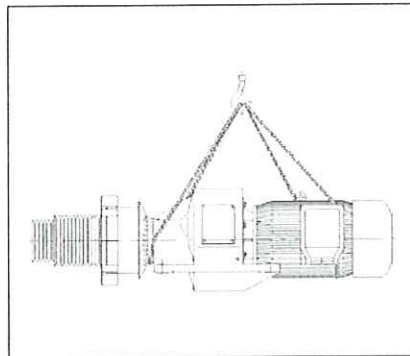

Fig. 142

- Install the drive with main motor.
- Fit belts and adjust the belt tension. To do this, adjust the lower spindle nuts. After correct adjustment, firmly tighten the upper spindle nuts, thereby securing the drive.
- Fit the secondary motor, see 4.11.2.
- Carry out electrical installation.
- Undo the bowl lock screws 11 by approx. 20 mm and lock them.

5.2.1 Drive belts (primary drive)

When tensioning and replacing the V-belts, note the following:

- The belt tension must also be checked when the decanter is supplied as a complete assembly.
- Check the belt tension after 4 - 8 operating hours.

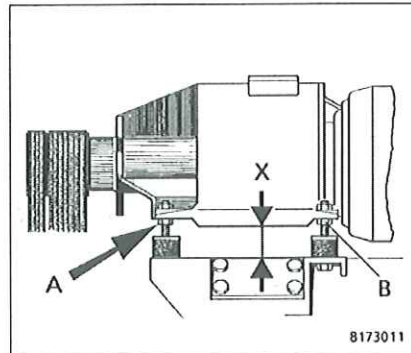

Fig. 143

Increasing the belt tension:

- Increase distance X. To do this, turn nuts A and B until the required belt tension is attained.
- Rotate the V-belts to ensure uniform stretching of the belts.

5.2.2 Direction of rotation

When looked at from the drive side, the bowl must rotate anticlockwise.

The direction of rotation can be changed by interchanging two lead-in wires in the motor control. The direction of rotation of peripheral equipment already connected must be taken into consideration.

5.2.3 Regulating ring

The regulating ring determines the overflow diameter of the bowl.

The overflow diameter can be altered by exchanging the regulating ring to vary the clarification and drying efficiency to suit the respective process requirements.

5.2.4 Removing the regulating ring



Do not loosen any part of the machine before the decanter bowl has come to a standstill.

- Always use complete tools and use them only for the intended application, see "Set of tools".
- Only use suitable hoists and load-carrying equipment.
- Dismantle main bowl bearing on the liquid side, see 4.10.1

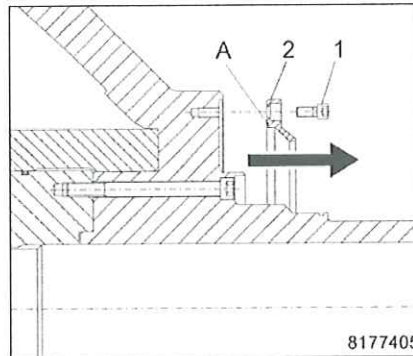

- Undo Allen screws 1 and dismantle regulating 2.
- Check gasket A and replace if necessary.

Fig. 144

5.2.5 Fitting the regulating ring

- Clean all parts carefully. Replace worn or damaged parts immediately.
- To ensure perfect running of the bowl, all plane surfaces and centering rims must be smooth and clean.
- Always use complete tools and use them only for the intended application, see "Set of tools".
- Only use suitable hoists and load-carrying equipment.
- Proceed in reverse order to fit the regulating ring.
- For further assembly, see: Fitting the main bowl bearing in section 4.10.1.

5.2.6 Dismantling the disk stack



Do not loosen any part of the machine before the decanter bowl has come to a standstill.

- Always use complete tools and use them only for the intended application, see "Set of tools".
- Only use suitable hoists and load-carrying equipment.
- Remove scroll, see 4.7.2.
- Leave the lifting device in mounted position.

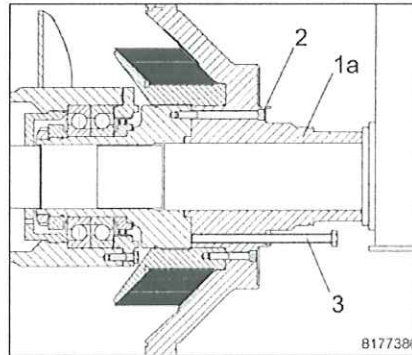

Fig. 145

- Undo Allen screws 1.
- Screw in 4 puller screws M16 (pos. 2) and evenly force the bearing hub with disk stack off the scroll.
- Place the bearing hub on a suitable surface and secure it against slipping.
- Remove the lifting device.

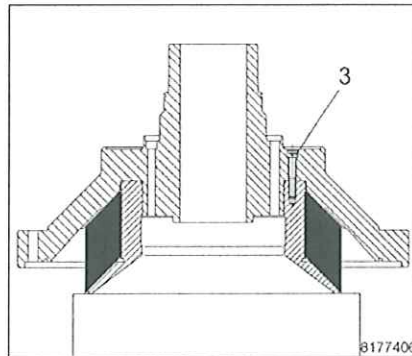

Fig. 146

- Rotate the bearing hub and place it on the disk support as illustrated.
- Undo Allen screws 3.

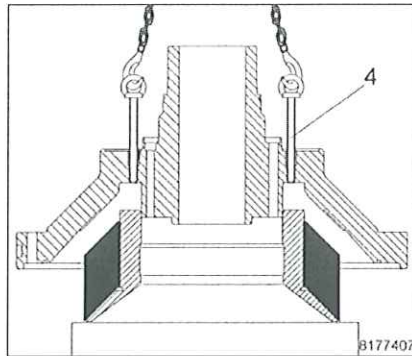

Fig. 147

- Fit two eye bolts from the "set of tools" as illustrated and raise the bearing hub off the disk stack with the aid of a hoist.
- Remove the individual disks from the disk support.
Important: Pay attention to the order of the disks!

5.2.7 Installing the disk stack

- Always use complete tools and use them only for the intended application, see "Set of tools".
- Only use suitable hoists and load-carrying equipment.



The height of the assembly space for the disk stack is 106.5 mm. To ensure an adequate pretension, the overall height of the disks must correspond to this dimension + 0.2 mm.

The number of disks change in dependence of the disk spacer height. So-called blind disks of varying thicknesses are available for fine adjustment of the height.

- Mount the disks in the correct order. The fitting position of the disks is defined by a groove-spring system.

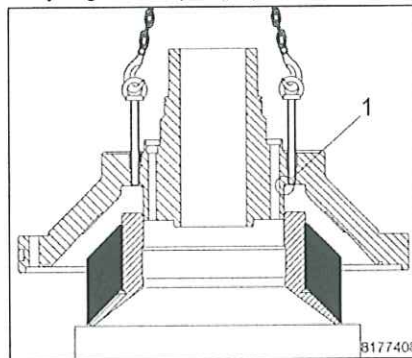

Fig. 148

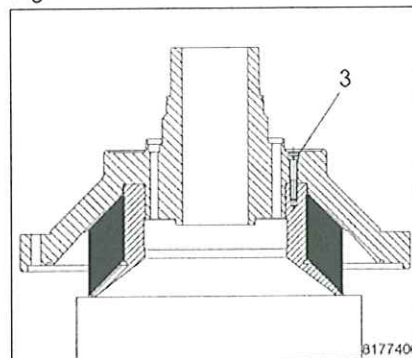

Fig. 149

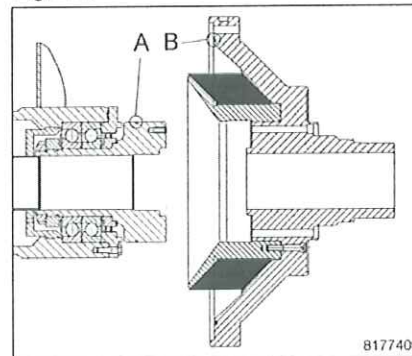

Fig. 150

- Fit bearing hub, see 4.7.3 .
- Mount scroll, see 4.7.4.

- Check gasket 1 and replace if necessary.
- Screw two guide rods M16 into the disk support.
- Position the bearing hub carefully over the guide rods on the disk support.
Important: Make sure that the puller threads in the bearing hub are in line with the corresponding surfaces on the disk support.

- Tighten 8 allen screws M 16x90 (pos. 3) evenly and crosswise.
Required screw quality:
A4-70

- Bring the bearing hub into a horizontal position and secure against slipping.
- Check gaskets A and B and replace if necessary.

5.3 Table of speeds

Note: For ordering spare parts refer to the machine-specific spare parts list.

Dekanter Typ CA 75 -,-12 mit 2-Gefriebe-Antrieb
 Décauteurs type CA75-,-12 avec entraînement à 2 engrénages
 Type decanter CA75-,-12 met 2-tras aandrijving

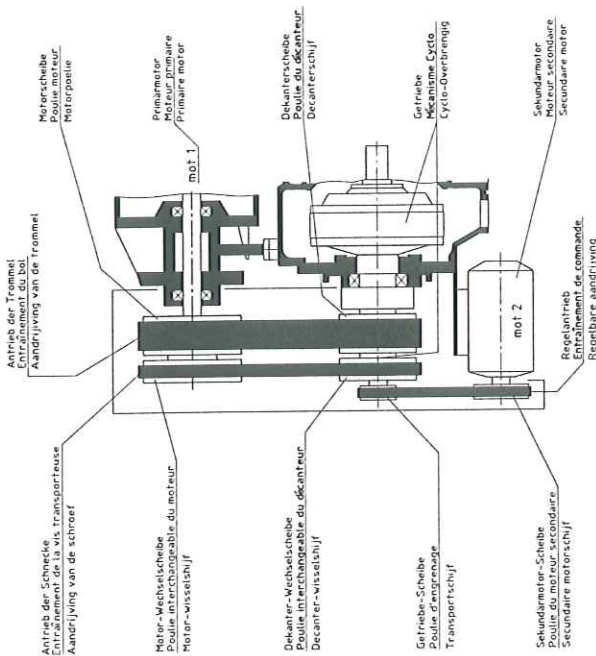

Fig. 151 8177-9056-090

1. Antrieb der Trommel / Aandrijving van de trommel

Motor-Scheibe		Dekanterscheibe		Trommeldrehzahl n _{Tr} in min ⁻¹ und Zentrifugalbeschleunigung Z=g bei folgender Motordrehzahl n	
Poelle moteur		Poelle du décanneur		Nombre de tours du bol n _{Tr} en t/mnet accélération centrifuge Z=g pour nombres de tours de moteur	
Motorpoelle		Decanterschijf		Trommelcentraal n _{Tr} in min ⁻¹ en centrifugaalversnelling Z=g bij de volgende motortoerentalen n _{Tr}	
Teil-Nr. Onderdeel-Nr.	Diam D _g mm *	Teil-Nr. Onderdeel-Nr.	Diam D _g mm *	n _{Tr}	z
8177-3354-040	297,5	8177-3352-000	328,3	2630	2900
8177-3354-050	286,1	8177-3352-010	339,5	2445	-
8177-3354-090	276,2	8177-3352-050	349	2290	2200
8177-3354-060	269,2	8177-3352-020	355,6	-	2630
8177-3354-070	250,4	8177-3352-030	373,2	-	2320

2. Antrieb der Schnecke, Getriebe
 Entraînement de la vis transporteuse, engrenage
 Aandrijving van de schroef, transmissie

Motor-Mechanische Poelle des Motors Motor-Mechanische Poelle des Motors	Diam ^g D _g mm	Teil-Nr. Onderdeel-Nr.	Diam ^g D _g mm	Analoge Regelung der Differenzdrehzahl d in min ⁻¹ von/à la vitesse différentielle d en t/m de/bà réglage analogique de la vitesse différentielle d en t/m van/rot bij		Teil-Nr. Onderdeel-Nr.	Stück Nombre	Länge L ₁ mm Langueur L ₁ mm	Teil-Nr. Onderdeel-Nr.	Diam D _{qm} mm	Teil-Nr. Onderdeel-Nr.	Malle No. de référence cotes male
				n _{Tr}	n _{Tr}							
8177-3355-050	320,5	8177-3354-060	400,0	1/13	2/4	8177-3479-020	12-6	3080/350	8177-3479-020	160	8177-3478-000	753,4x212
8177-3355-060	301,8	8177-3354-070	417,6	5/17	2/4	8177-3479-020	12-6	3080/350	8177-3479-020	160	8177-3478-000	753,4x212
8177-3355-100	286,8	8177-3354-030	421,4	9/21	3/15	8177-3479-020	12-6	3080/350	8177-3479-020	160	8177-3478-000	753,4x212
8177-3355-110	272,8	8177-3354-040	440,0	1/13	3/15	8177-3479-020	12-6	3080/350	8177-3479-020	160	8177-3478-000	753,4x212
8177-3355-130	203,1	8177-3354-070	440,0	16/28	10/24	8177-3479-020	12-6	3080/350	8177-3479-020	160	8177-3478-000	753,4x212
8177-3355-160	185,1	8177-3354-030	431,4	20/32	16/26	8177-3479-020	12-6	3080/350	8177-3479-020	160	8177-3478-000	753,4x212
8177-3355-150	151,6	8177-3354-040	459,4	23/35	20/32	8177-3479-020	12-6	3080/350	8177-3479-020	160	8177-3478-000	753,4x212

* d_{qm} mm durch Korrektur an Frequenzumformer begrenzt
 * d_{qm} mm limité par réglage sur le convertisseur de fréquence
 * Richtdurchmesser
 * Diamètre recommandé
 * Richtdiameter

M=68%

5.4 Altering the speed

The belt pulleys are selected to suit the product. The following must be kept in mind when altering the speed:

- Only use suitable hoists and load-carrying equipment.
- Always use complete tools for the job they were designed for, see "Set of tools".
- Always replace the belt pulleys in pairs. Only then can the belts be accurately tensioned.
 - To alter the differential speed, replace exchangeable motor pulley 10 and exchangeable decanter pulley 12.
 - To alter the bowl speed, replace motor belt pulley 11 and decanter belt pulley 13.
- The available belt pulleys and drive belts are listed in the table of speeds (5.3).



Fig. 152

- Do not under any circumstances manipulate the frequency converter to exceed the permissible bowl speed (see name-plate).
- The machine may only be operated with an independent device for speed limiting.

5.4.1 Replacing the exchangeable motor pulley

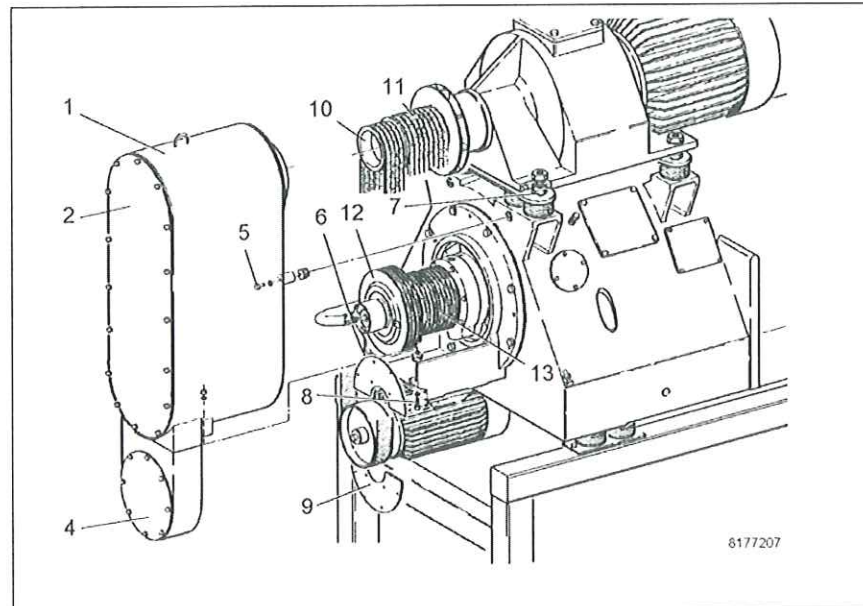

Fig. 153

Removal



Do not loosen any part of the machine before the decanter bowl has come to a standstill.

- Remove cover plates 2 and 4.
- Unscrew oil feed 6 (be sure to use two wrenches).
- Loosen clip on the decanter housing for the speed sensor holder. Unscrew the holder, pull it out a little and remove.
- Slacken and remove the flat belt.
- Slacken V-belts by turning hexagon nuts 7 and lower the drive. Remove the V-belts.
- Remove plates 9 in front of the secondary motor.
- Detach oil feed to the main bowl bearing.
- Suspend guard 1 from a hoist. Undo fastening screws 5 and 8 and remove the guard.

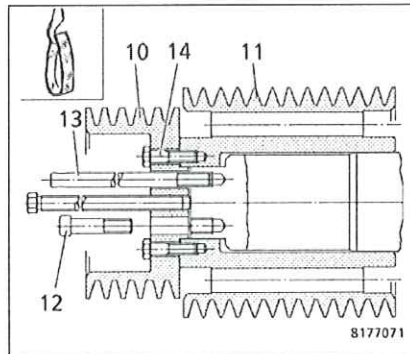

Fig. 154

- Undo Allen screws 12. Screw in two threaded spindles 13 as guides.
- Force off belt pulleys 10 and 11 together.
- Undo hex head screws 14. Force the two belt pulleys apart.

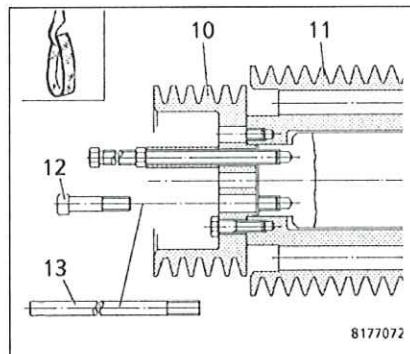

Fig. 155

Fitting

- Clean all parts thoroughly. Replace worn or damaged parts immediately.
- Fasten belt pulleys 10 and 11. Required torque 65 Nm (greased screws).
- Screw in two threaded spindles 13 as guides.
- Mount the belt pulleys as shown.

5.4.2 Replacing the exchangeable decanter pulley



Do not loosen any part of the machine before the decanter bowl has come to a standstill.

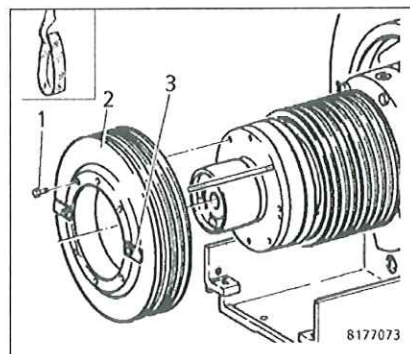

Fig. 156

- Remove the guard, see 5.4.1.
- Undo hex head screws 1. Force off and remove belt pulley 2.

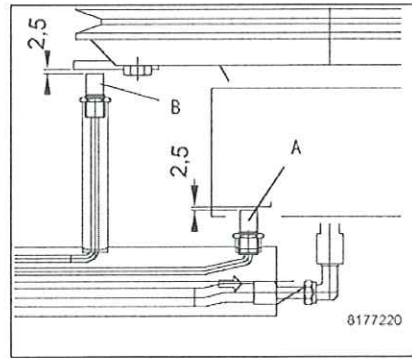

Fig. 157

- Clean all parts thoroughly. Replace worn or damaged parts immediately.
- Fit speed sensor plates diametrically opposite each other. Check the clearance between the plates and proximity switches A and B and re-adjust if necessary. Specified dimension = 2.5 mm.

5.4.3 Replacing the motor belt pulley

See chapter 5.4.1.

5.4.4 Replacing the decanter belt pulley

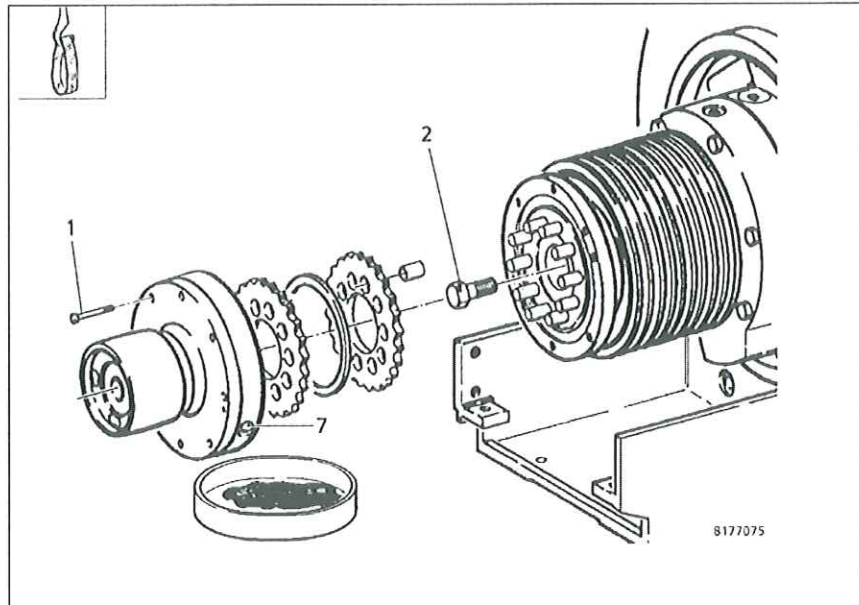

Fig. 158

Removal



Do not loosen any part of the machine before the decanter bowl has come to a standstill.

- Remove the exchangeable decanter pulley, see 5.4.2 .
- Put an oil collecting pan underneath. Drain the oil; unscrew the two oil drain screws 7.
- Undo Allen screws 1. Mount the guide bolt. Suspend the secondary gear in a hoist.
- Open the secondary gear using puller screws (2xM10). Pull out the gear flange and circular housing together while holding the shaft (e.g. with a wrench through the bolts).

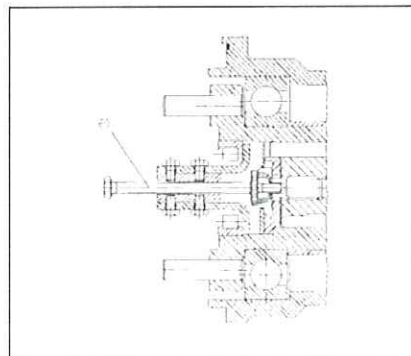

Fig. 159

- Dismantle the cylindrical roller bearing.

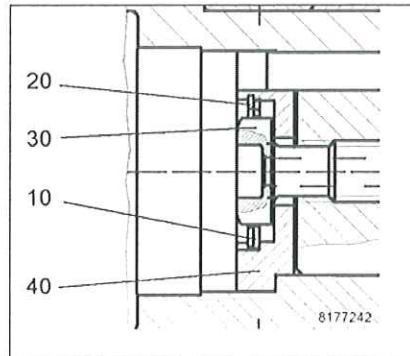

Fig. 160

- Remove retaining ring 20 and locking device 10.
- Undo hex head screw 30.
- Remove arresting disk 40.

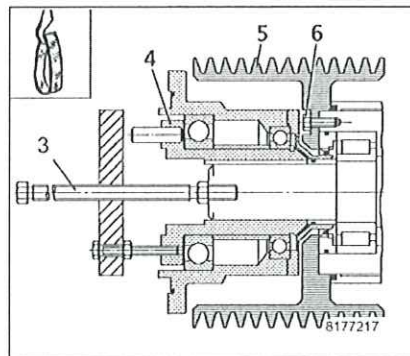

Fig. 161

- Mount pulling device. Suspend bearing housing in a hoist.
- Turn hexagon nut 3 and pull hub 9 off the shaft end.
- Unscrew hex head screws 6 and decanter belt pulley 5 (2xM12).

Fitting

Assembly is carried out in reverse order. Note the following:

- Clean all parts carefully. Replace worn or damaged parts immediately.
- Always fit the oil drain screws with new gaskets.

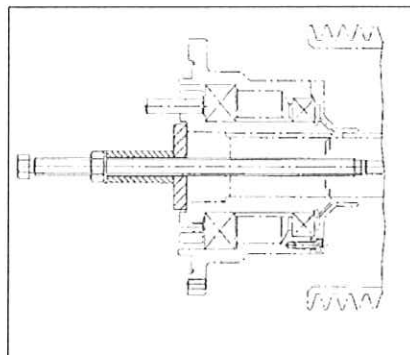

Fig. 162

- Mount hub as shown.

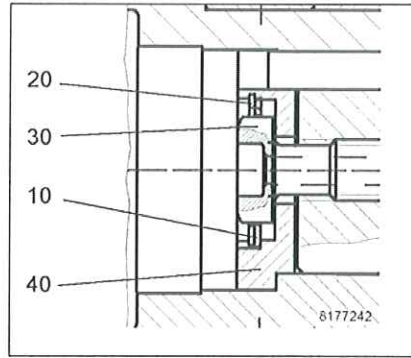

Fig. 163

- Remove arresting disk 40. Place the recess of the arresting disk over the feather key.
- Tighten hex head screw 30. Required torque for greased screws: 160 Nm.
- Fit locking device 10; it may be necessary to turn it to find the correct position.
- Fit retaining ring 20.



Take the Best – Separate the Rest

A company of GEA Group

Westfalia Separator Industry • Werner-Habig-Straße 1 • D-59302 Oelde (F.R. Germany)
Tel.: +49 (0) 25 22 / 77-0 • Fax: +49 (0) 25 22 / 77-24 88 •

<http://www.westfalia-separator.com/> • <mailto:info@gea-westfalia.de>